



Supplement to Yanmar Kit Installation Instructions

SAFETY

This product is designed and intended only for use with a YANMAR engine. All safety and warning information contained in the Yanmar Operation Manual and Service Manual is adopted and incorporated to apply to the components, accessories, and parts that are utilized with Yanmar engines. Follow all instructions and precautions before installing this product, before operating, during operation, and during periodic maintenance procedures for your safety, the safety of others, and to protect the performance of your engine.



Item	Part No.	Description	Quantity	Remarks
1	129087-66061*	Cable, Throttle (Vernier)	1	
2	124756-67510*	Retainer, Throttle Cable	1	
3	22272-000070*	E-clip	1	
4	26116-040128*	Bolt, M4x0.7-12	1	
5	26716-040002*	Nut, M4x0.7	1	
6	119749-91161*	Bracket, Throttle Cable	1	
7	26106-080252*	Bolt, M8x1.25-25 (Flanged Hex Head)	3	
8	22137-080000*	Washer, M8	4	
9	119749-08000*	Bracket, Fuel Filter	1	
10	119749-08010*	Spacer, Fuel Filter	1	
11	26106-080552*	Bolt, M8x1.25-55 (Flanged Hex Head)	1	

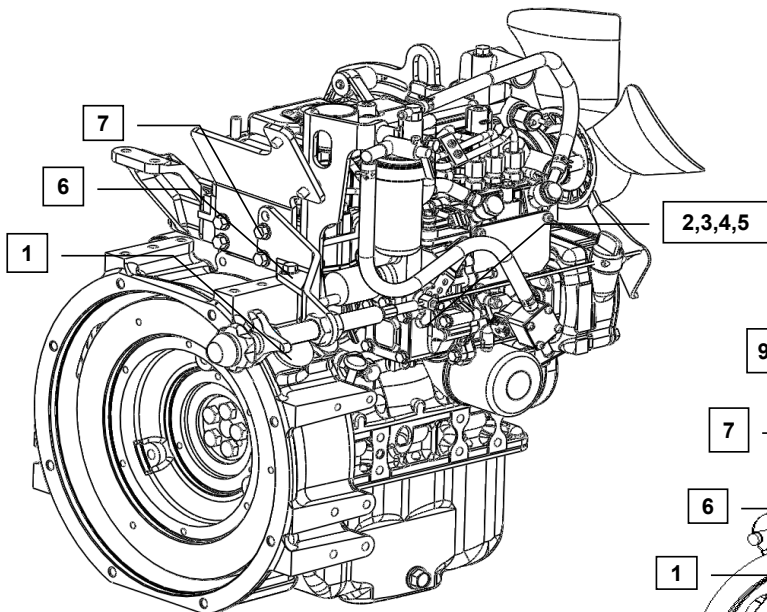

3TNM68

MODELS

3TNM68
3TNM72

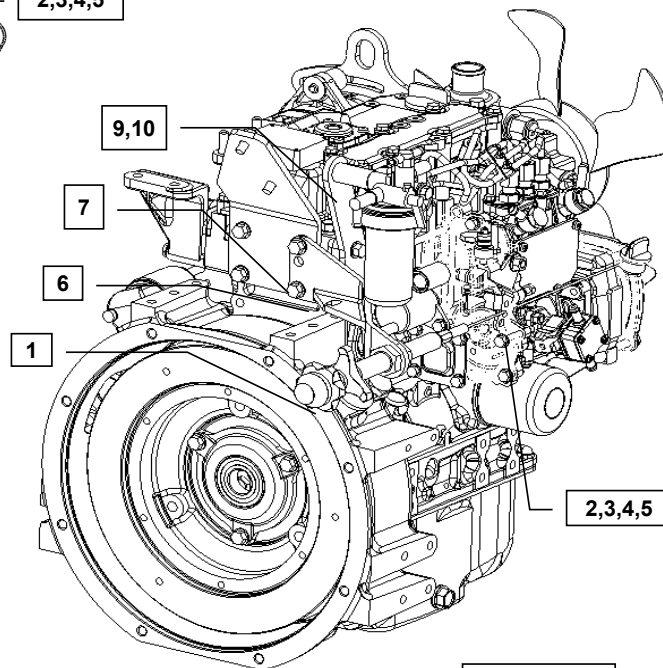

3TNM72

Note: Service parts are denoted by an asterisk. To replace non-service parts, the entire kit will need to be purchased.



Installation Instructions

Hand tighten all bolts and nuts until assembly is completed, then torque according to specifications in Table 1. The numbers in () below reference the item numbers on page 1.

Throttle control bracket assembly:

3TNM68:

- 1a. Remove two bolts from the rear fuel injection side of the cylinder head. Place the Throttle Cable Bracket (6) into position as noted in the figure above. Hand tighten the M8 x 1.25 - 25 Bolts (7). Torque the bolts according to the specifications in Table 1.

NOTE: The 3TNM68 models will utilize the lower and middle bolt holes on the speed control bracket.

3TNM72:

- 1b. Remove the existing fuel filter assembly and bracket. Install the provided Fuel Filter Bracket and Spacer (9,10). Reinstall the fuel filter.
- 2b. Remove two bolts from the rear fuel injection side of the cylinder head. Place the Throttle Cable Bracket (6) into position as noted in the figure above. Hand tighten the M8 x 1.25 - 25 bolts (7). Torque the bolts according to the specifications in Table 1.

NOTE: The 3TNM72 models will utilize the lower and upper bolt holes on the Speed Control Bracket.

Throttle cable assembly:

3. Remove the wire from the conduit and cut the conduit to the appropriate length. Reinstall the wire into the conduit.
4. Insert the speed control assembly wire in the retainer (2), and make sure the speed control knob is all the way down.
5. Insert the retainer (2) to the lower hole of the Throttle Control Lever, and insert the E-clip (3) to the groove closer to the retainer body. Tighten the M4 x 0.7 - 12 Bolt (4) and M4 Lock Nut (5) enough to secure the throttle cable. After tightening, make sure the Throttle Control Lever is up against the idle stop adjustment screw.
6. The wire should extend at least 10 mm past the Cable Retainer. Cut off the excess wire.
7. Tighten all remaining nuts and bolts per the tightening torque stated in Table 1.

NOTE: Comply with torque standards in the table to avoid unexpected damage during installation or in the future.

Table 1: Tightening Torque

Diameter x Pitch	Kgf-m	Foot-lbf	N-m
M8 x 1.25	1.5 ~ 2.9	10.6 ~ 20.9	14.4 ~ 28.3
M10 x 1.50	4.5 ~ 5.5	32.5 ~ 39.8	44.0 ~ 54.0
M12 x 1.75	8.0 ~ 10.0	57.8 ~ 72.3	78.4 ~ 98.0