



Supplement to Yanmar Kit Installation Instructions

SAFETY

This product is designed and intended only for use with a YANMAR engine. All safety and warning information contained in the Yanmar Operation Manual and Service Manual is adopted and incorporated to apply to the components, accessories, and parts that are utilized with Yanmar engines. Follow all instructions and precautions before installing this product, before operating, during operation, and during periodic maintenance procedures for your safety, the safety of others, and to protect the performance of your engine.

Kit Name: KS1



Item	Part No.	Description	Quantity	Remarks
1	529F88-01760	Spacer, FWH	1	Spacer for Semi FWH
2	Bolt	M10 Bolt	12	Not Provided

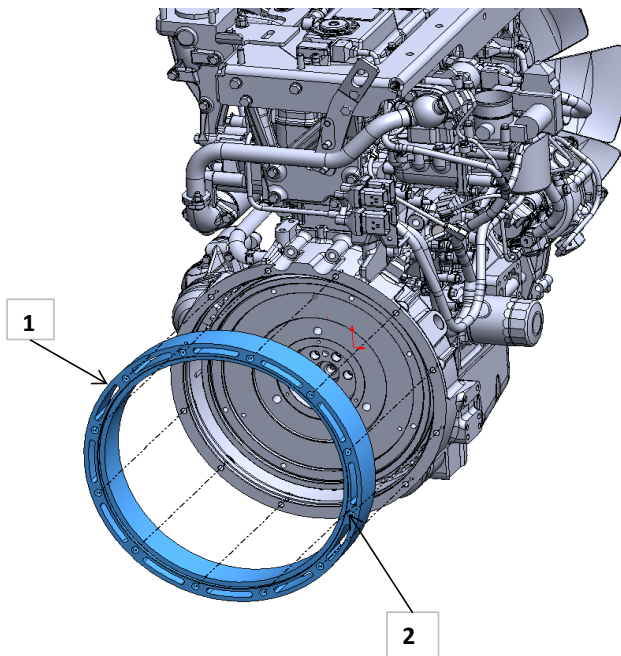

MODELS

Tier 4
4TNV94FHT-NYEA2-PPH-SEMI
4TNV98CT-NYEA2-PPH-SEMI

Notes: Parts code is not assigned to non-servicable component parts.

Remarks:

The length of M10 bolt completely depends upon the size of the P.T.O, that will be assembled on top of the Spacer Kit.



Installation Instructions

Hand tighten all bolts and nuts until assembly is completed, then torque according to specifications in Table 1.

The numbers in () below reference the item numbers on page 1.

1. Align the FWH Spacer (1) and P.T.O onto the Flywheel Housing as per the bolt pattern and hand tighten the 12 M10 bolts (2).
2. Torque down the M10 bolts (2) as per the torque standards listed on the table below.

NOTE: Comply with torque standards in the table to avoid unexpected damage during installation or in the future.

Table 1: Tightening Torque

Diameter x Pitch	Kgf-m	Foot-lbf	N-m
M8 x 1.25	1.5 ~ 2.9	10.6 ~ 20.9	14.4 ~ 28.3
M10 x 1.50	4.5 ~ 5.5	32.5 ~ 39.8	44.0 ~ 54.0
M12 x 1.75	8.0 ~ 10.0	57.8 ~ 72.3	78.4 ~ 98.0