



Supplement to Yanmar Kit Installation Instructions

SAFETY

This product is designed and intended only for use with a YANMAR engine. All safety and warning information contained in the Yanmar Operation Manual and Service Manual is adopted and incorporated to apply to the components, accessories, and parts that are utilized with Yanmar engines. Follow all instructions and precautions before installing this product, before operating, during operation, and during periodic maintenance procedures for your safety, the safety of others, and to protect the performance of your engine.



Item	Lev	Part No.	Description	Quantity	Remarks
1	-	119E34-44740	Bracket, RightSide	1	
2	-	119E34-44750	Bracket, Left Side	1	
3	-	119E34-44760	Support, Upper	1	
4	-	119E34-44770	Mount, Upper	1	
5	-	119E34-44780	Spacer	1	
6	-	119E34-44790	Bracket, Bottom	1	
7	-	129689-44860*	Large OD Plain Washer, 0.5 X 2.0 X 0.125	2	
8	-	26366-080002*	Hex Serrated Flange Nut, M8 - 1.25	2	
9	-	129689-44870*	Hex Cap Screw, 1/2-13 X 2.75	2	
10	-	119E34-44910	Hex Serrted Flange Screw, M10-1.5 X 25	8	
11	-	26106-080162*	Hex Serrated Flange Screw, M8-1.25 X 16	4	
12	-	129689-44880*	Isolator, 32 X 32, M8-1.25	2	
13	-	129689-44890*	Isolator, 46.4mm, 51.21mm, 1/2-13	2	

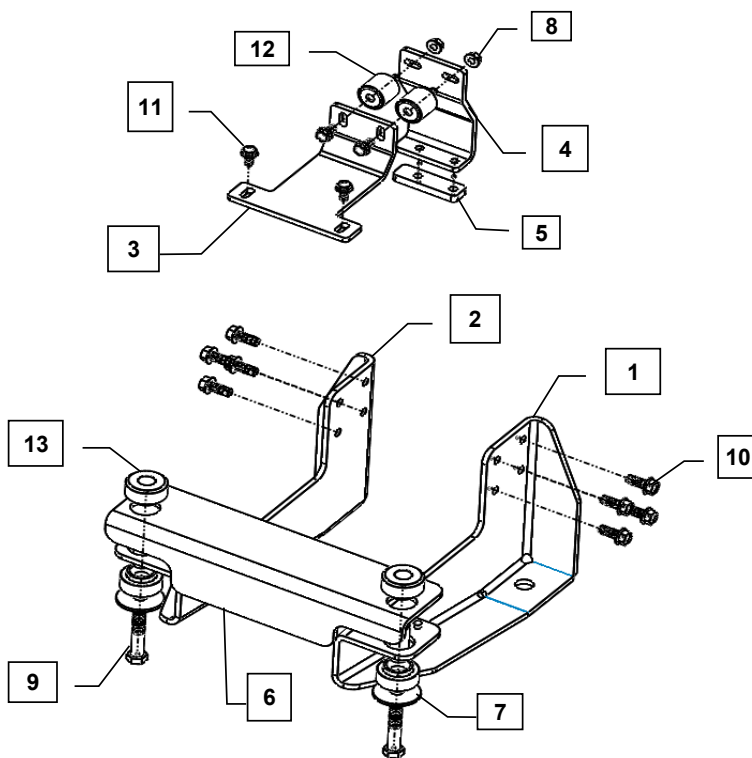

MODELS
3TNV80FT

Note: Service parts are denoted by an asterisk. To replace non-service parts, the entire kit will need to be purchased.



Installation Instructions

Hand tighten all bolts and nuts until assembly is completed, then torque according to specifications in Table 1. The numbers in () represent the item numbers.

1. Remove the two M8 X1.25 - 75mm bolts on the front top of the engine cylinder head as shown in the picture 1 below and fasten the Spacer (5) and Upper Mount (4) to the same location using same M8 X1.25 - 75mm bolts.
2. Fasten M8 Isolators (12) and Support Mount (3) to the Upper Mount (4) using M8 X 1.25 - 16mm bolt (11) and M8 X 1.25 nut (8).
3. Assemble Right Front Leg (1) and Left Front Leg (2) to engine mounting pads using M10 X 1.5 - 25mm bolts (10) provided in the kit.
4. Locate Radiator Bottom Bracket (6) onto Front Legs using guide pins. Assemble Isolators (13) in large openings at the sides of the Cross Bracket.
5. Install the Radiator Kit and refer to Radiator Kit instructions to complete assembly.

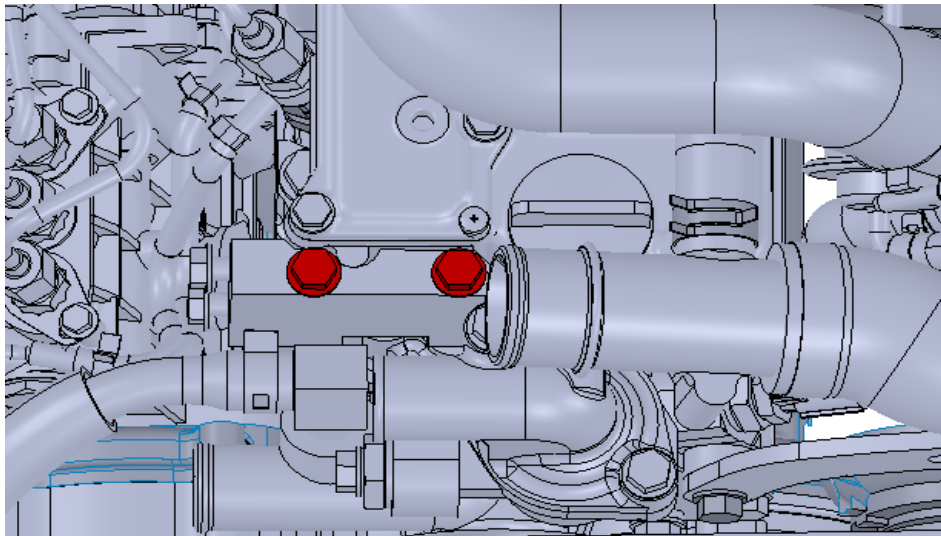

Picture1: Upper Bracket Mounting Location.

NOTE: Comply with torque standards in the table to avoid unexpected damage during installation or in the future.

TABLE 1: Tightening Torq

Diameter x Pitch	Kgf-m	Foot-lbf	N-m
1/2 X 13	7.9 ~ 10.1	57 ~ 73	77.3 ~ 98.9
M8 x 1.25	1.5 ~ 2.9	10.6 ~ 20.9	14.4 ~ 28.3
M10 x 1.50	4.5 ~ 5.5	32.5 ~ 39.8	44.0 ~ 54.0