



Supplement to Yanmar Kit Installation Instructions

SAFETY

This product is designed and intended only for use with a YANMAR engine. All safety and warning information contained in the Yanmar Operation Manual and Service Manual is adopted and incorporated to apply to the components, accessories, and parts that are utilized with Yanmar engines. Follow all instructions and precautions before installing this product, before operating, during operation, and during periodic maintenance procedures for your safety, the safety of others, and to protect the performance of your engine.



Item	Part No.	Description	Quantity	Remarks
1	129689-44910*	Bracket, Left Side	1	
2	129689-44920*	Bracket, Right Side	1	
3	129689-44930*	Plate, Rad Bottom Brkt	1	
4	129689-44770	Mount, Upper	1	
5	129689-44780	Support, Upper	1	
6	129689-44310*	Washer, Plain 10mm, (ANSI B18.22.1)	8	
7	129689-44320*	Washer, Lock 10mm, (BS 4464) (Helical spring)	8	
8	129689-44330*	Bolt, M10 X 1.5 - 25 (Flanged hex head)	8	
9	129689-44860*	Washer, Plain 0.500 X 2.00 X 0.125, (ANSI B18.22.1)	2	
10	129689-44280*	Nut, M8 X 1.25, (Flanged, serrated, hex head)	1	
11	129689-44960*	Bolt, 1/2 X 13 - 2 1/2, (Hex), (ANSI B18.22.1)	2	
12	129689-44290*	Bolt, M8 X 1.25 - 16, (Flange, serrated hex head), Class 90	5	
13	129689-44880*	Isolator, 32 X 32, M8 X 1.25 Stud	1	
14	129689-44890*	Isolator, 46.4mm, 51.21mm, 1/2 X 13	2	

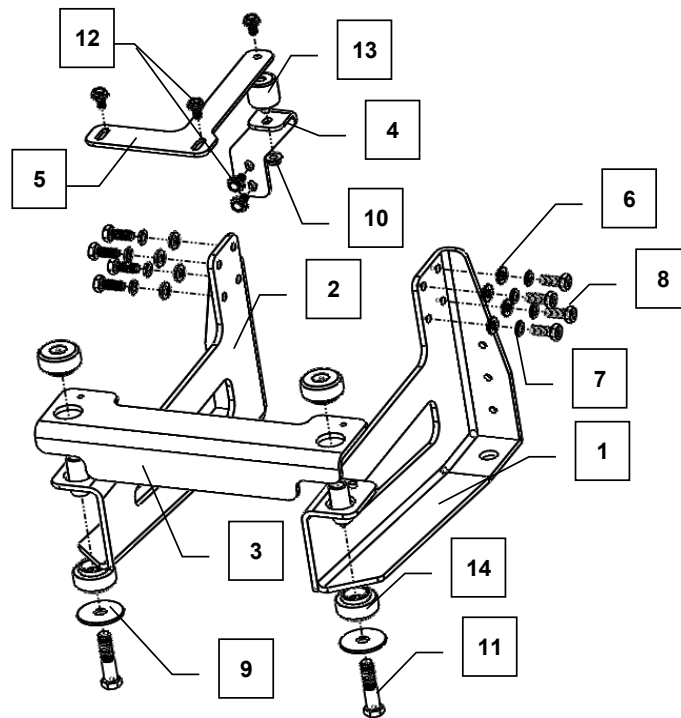

MODELS
3TNV88F-ESGY

Note: Service parts are denoted by an asterisk. To replace non-service parts, the entire kit will need to be purchased.



Installation Instructions

Hand tighten all bolts and nuts until assembly is completed, then torque according to specifications in Table 1. The numbers in () represent the item numbers.

1. Using two M8 X 1.25 -16mm bolts (12), fasten the Upper Mount (4) to the front of the cylinder head.
2. Fasten M8 Isolator (13) and Top Mount (5) to Upper Mount using M8 X 1.25 - 16mm bolt (12) and M8 X 1.25 nut (10).
3. Assemble Right Front Leg (1) and Left Front Leg (2) to engine mounting pads using Washers (6), Lock Washers (7) and M10 X 1.5 - 25mm bolts (8) provided in the kit.
4. Locate Radiator Bottom Bracket (3) onto Front Legs using guide pins. Assemble Isolators (14) in large openings at the sides of the Cross Bracket.
5. Install the Radiator Kit and refer to Radiator Kit instructions to complete assembly.

NOTE: Comply with torque standards in the table to avoid unexpected damage during installation or in the future.

TABLE 1: Tightening Torque

Diameter x Pitch	Kgf-m	Foot-lbf	N-m
M8 x 1.25	1.5 ~ 2.9	10.6 ~ 20.9	14.4 ~ 28.3
M10 x 1.50	4.5 ~ 5.5	32.5 ~ 39.8	44.0 ~ 54.0