



Supplement to Yanmar Kit Installation Instructions

SAFETY

This product is designed and intended only for use with a YANMAR engine. All safety and warning information contained in the Yanmar Operation Manual and Service Manual is adopted and incorporated to apply to the components, accessories, and parts that are utilized with Yanmar engines. Follow all instructions and precautions before installing this product, before operating, during operation, and during periodic maintenance procedures for your safety, the safety of others, and to protect the performance of your engine.



Item	Lev. O	Part No.	Description	Quantity	Remarks
1	-	129G88-42800*	COVER KIT, V-BELT, KG3	1	KG3
2	--	129G88-42850	COVER, V-BELT	1	
3	--	129G88-42860	COVER, V-BELT	1	
4	--	129G88-42870	COVER, V-BELT	1	
5	--	119E34-44900	SLOTTED HEX WASHER HEAD TAPPING SCREW, #	12	
6	-	129G88-44110	RADIATOR KIT, 107F	1	KR20
7	--	129G88-44560	FAN GUARD	1	
8	--	129G88-44570	FAN GUARD	1	
9	--	129G88-44600	FAN, SHROUD	1	
10	--	129G88-96610	HEX SERRATED FLANGE BOLT, M6 -1.00 X 16	11	
11	-	129G88-44250*	KIT, DEGAS TANK	1	KRD1
12	--	129G88-44610*	TANK, DEGAS	1	
13	--	119E34-44600*	CAP, RADIATOR	1	
14	-	129G88-44201*	RADIATOR MOUNT KIT, KRM17	1	KRM17
15	--	129G88-44300*	LEG, ENGINE	1	
16	--	129G88-44310*	LEG, ENGINE	1	
17	--	129G88-44320*	MOUNT, UPPER	1	
18	--	129G88-44340*	BRACKET, TOP MOUNT, ALT	1	
19	--	129G88-44330*	BRACKET, RADIATOR	1	
20	--	129689-44860*	LARGE OD PLAIN WASHER, 0.500 X 2.00 X 0.125	2	
21	--	129689-44280	NUT, M8-1.25	4	
22	--	129G90-44870	HEX CAP SCREW, 1/2-13 X 2.625	2	
23	--	129689-44290	HEX SERRATED FLANGE SCREW, M8-1.25 X 16	2	
24	--	129G88-44290	HEX SERRATED FLANGE SCREW, M12-1.75 X 25	16	
25	--	129F88-44360*	ISOLATOR, M8-1.25	2	
26	--	129689-44890*	ISOLATOR, 46.4MM, 51.21MM, 1/2-13	2	
27	--	129G90-44350	BRACKET RADIATOR	1	For Enclosed Version
28	--	22117-080000	WASHER, M8	2	
29	--	26116-080502	HEX CAP SCREW, M8-1.25 X 50	2	
30	-	129G88-44530	HOSE KIT	1	KRP2
31	--	129G88-44440	PIPING, CAC	1	
32	--	129G88-44450	PIPING, CAC	1	
33	--	129G88-44460	HOSE, LOWER	1	
34	--	129G88-44470	HOSE, UPPER	1	
35	--	129G88-44480	HOSE, RETURN, DEGAS TANK	1	
36	--	129G88-44490*	HOSE, SPOOLED, 175MM	1	
37	--	129G88-44370	COUPLING, CAC	3	
38	--	129G88-44380	COUPLING, CAC, REDUCER	1	
39	--	129989-44200	HOSE, CLAMP, 40-64 OD	4	
40	--	129F88-44390	HOSE, CLAMP, 57-79 OD	1	
41	--	129F88-44430	HOSE, CLAMP, 11-20 OD	2	
42	--	129F88-44420	HOSE, CLAMP, 17-32 OD	2	
43	--	129G88-44390	HOSE, CLAMP, 45-67 OD	7	
44	--	129G88-44400	HOSE, CLAMP P-TYPE	1	
45	--	129G88-96610	BOLT, M16X16	1	
46	--	22137-060000*	WASHER, M6	2	

MODELS

4TN107FTT-1SYA2

Notes: Service parts are denoted by an asterisk. To replace non-service parts, the entire kit will need to be purchased.

Fig. 1

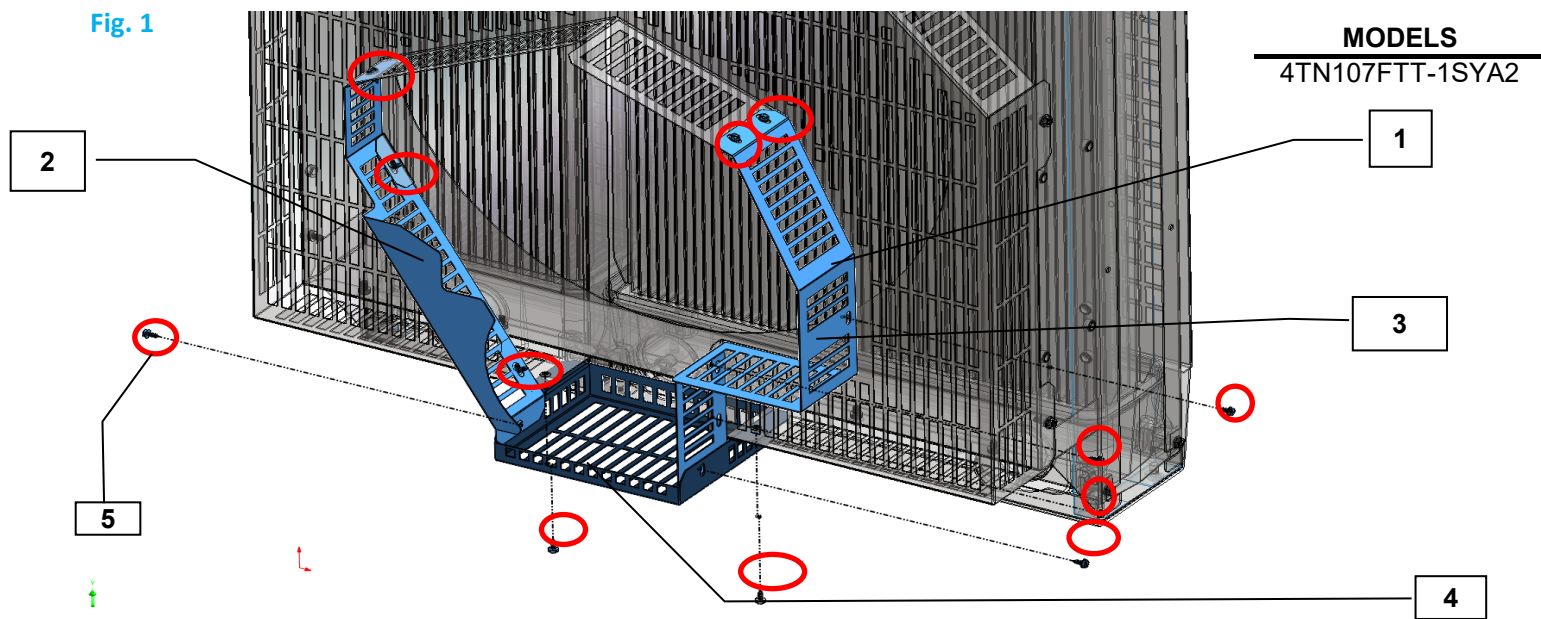
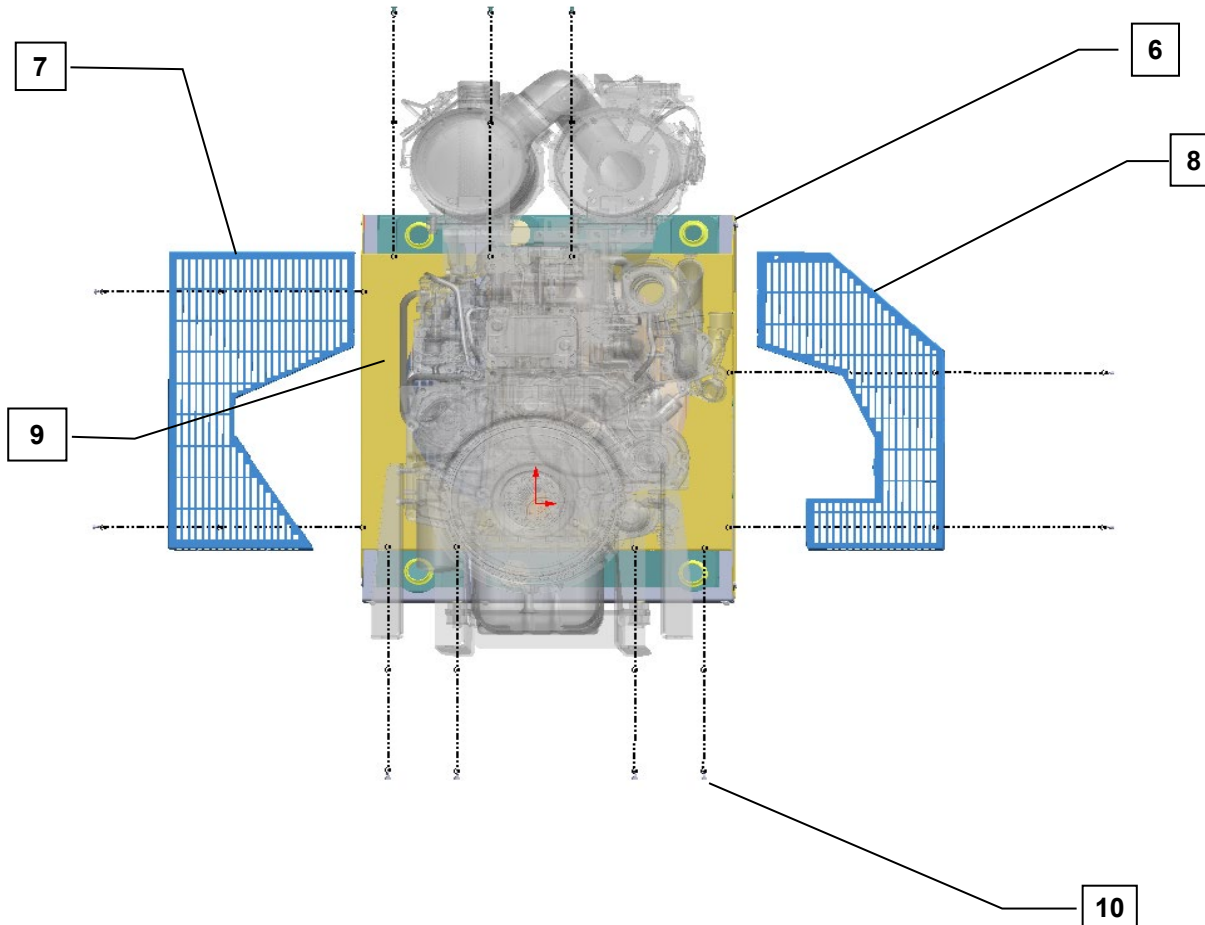

Fig. 2



Remarks:

MODELS
4TN107FTT-1SYA2

Fig. 3

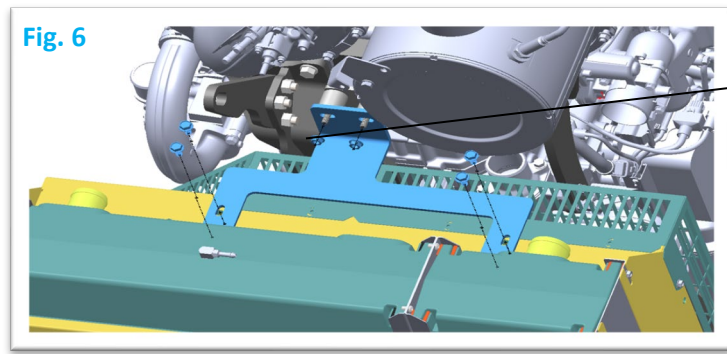
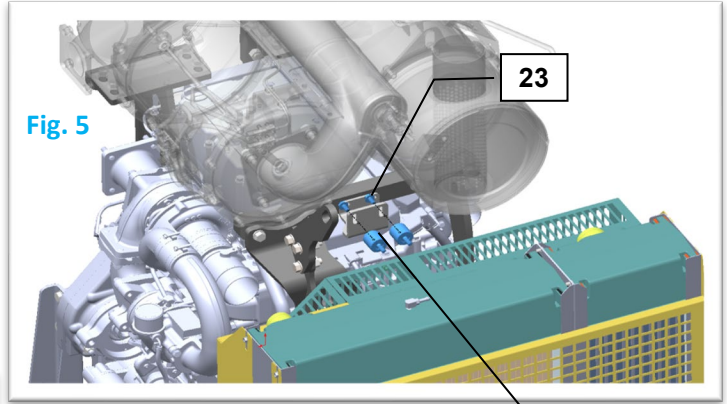
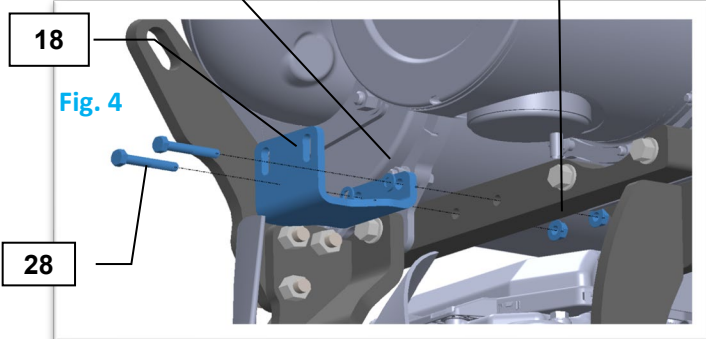
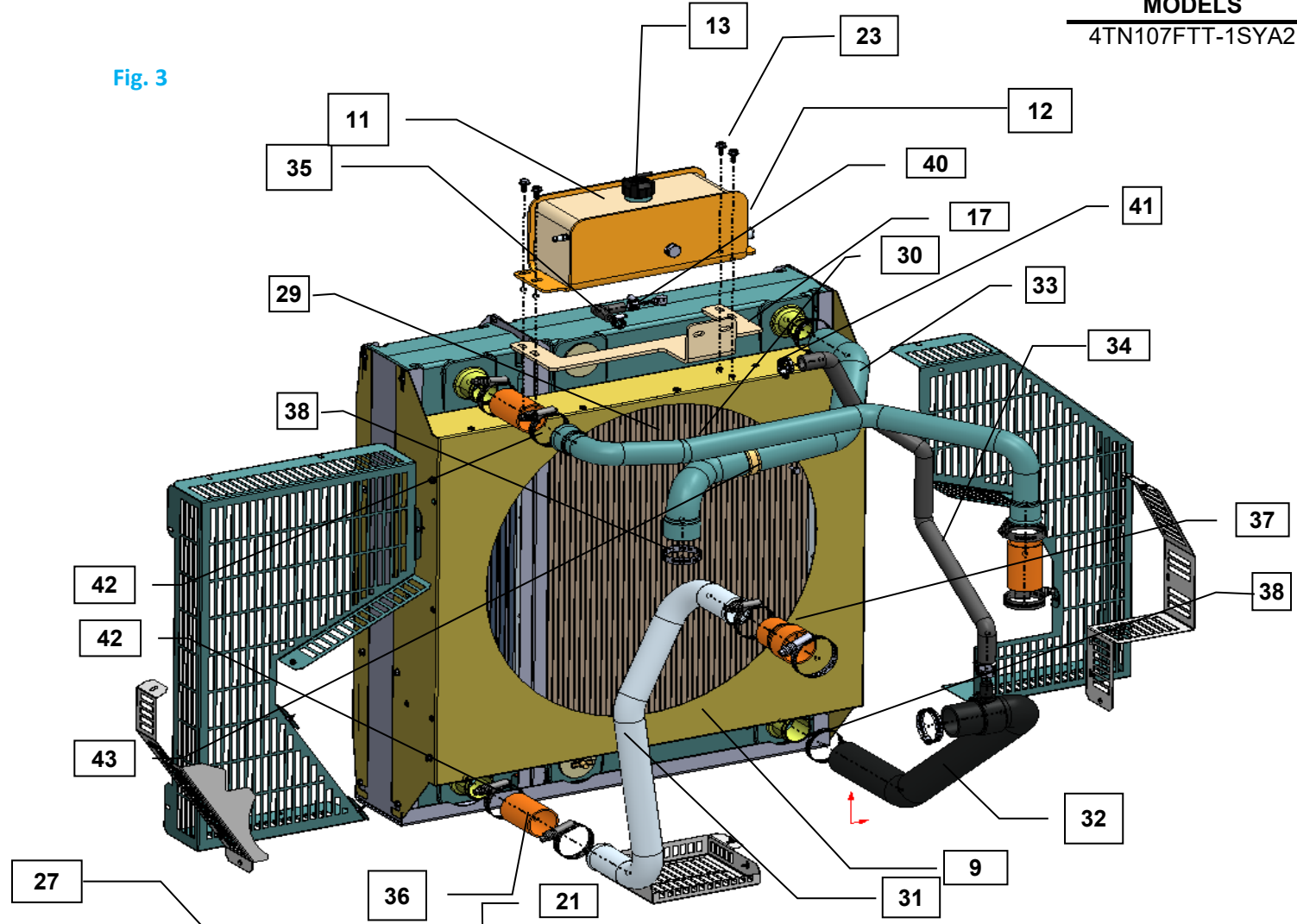

Remarks:

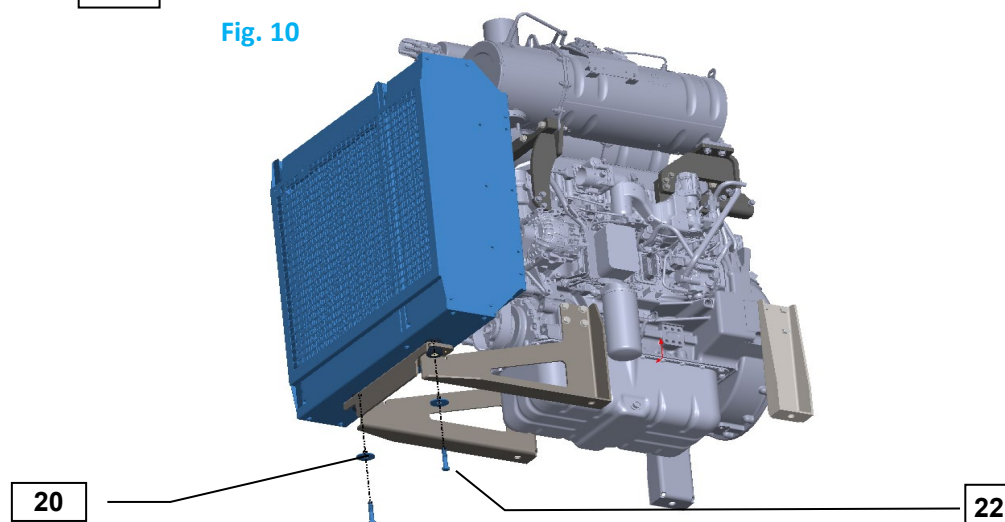
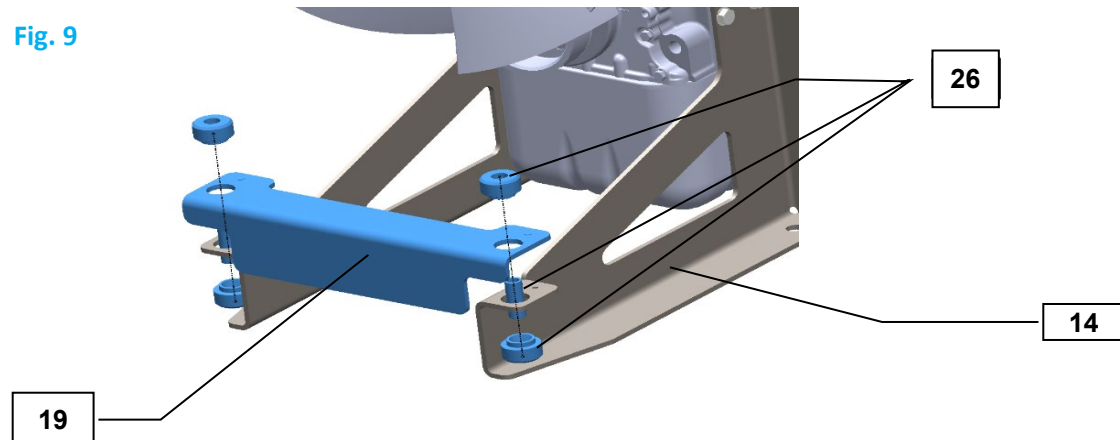
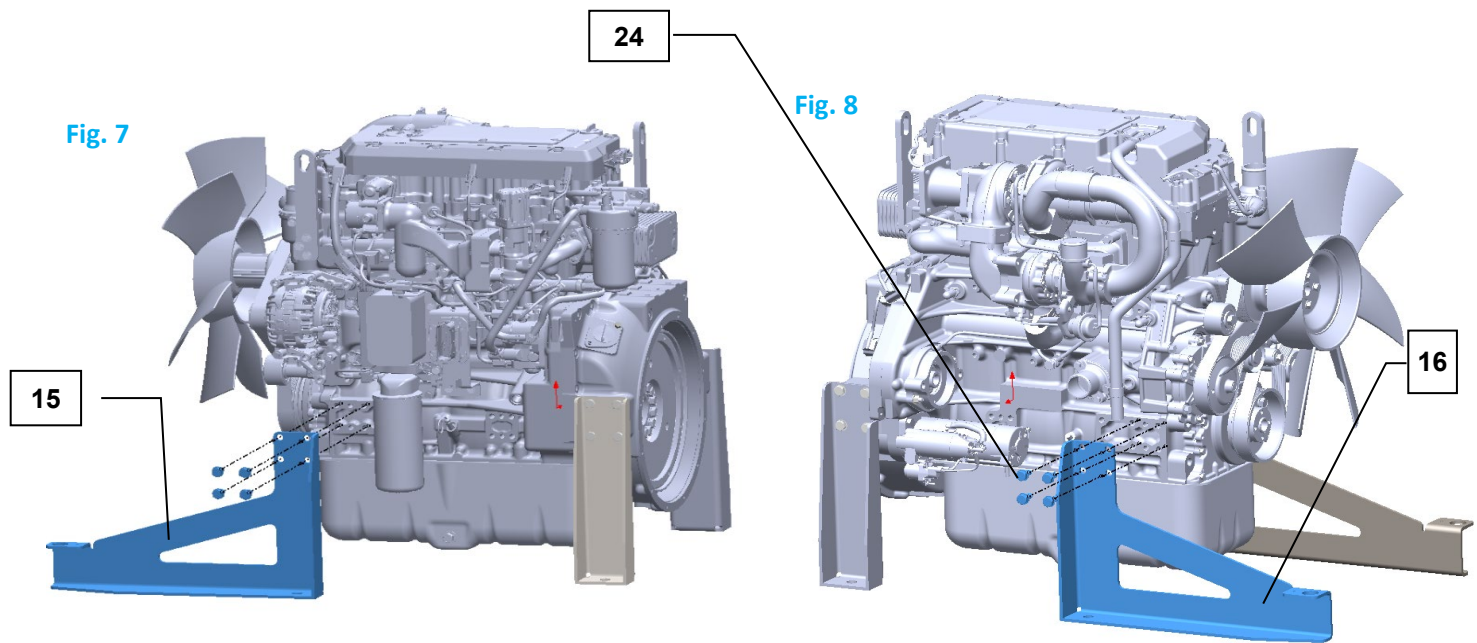

Remarks:



Installation Instructions

Hand tighten all bolts and nuts until assembly is completed, then torque according to specifications in Table 1. The numbers in () represent the item numbers.

WARNING: DO NOT RUN ENGINE WITHOUT COOLANT IN RADIATOR.

1. Install the Radiator Mounting Feets (15&16) with the M12 Bolts (24) as shown in Fig. 7 & 8. Place Rad. Bottom BK Plate (19) on the Mounting Feets (15&16) and assemble the isolators (26) as shown in Fig. 9. Also, install the Radiator Upper Mount bracket (18) using the M8 Screw (28), Washer (27) and Nut (21) as shown in Fig. 4.
2. Disassemble the Radaitor Fan guard (7&8) from the Radiator Kit (6), and assemble the Rad.(Minus Fan Guard) to the Bottom Bk Plate using Washer (20) and Screw (22) as shown in Fig. 10.
3. Assemble the Fan Guard (7&8) back using Bolts (10) as shown in Fig. 2. Now, Mount Belt Guards (2,3&4) using Bolts (5) as shown in Fig. 1.
4. Assemble Isolators (25) to the Upper mount bracket using Bolts (23) as shown in Fig. 5. Now, assemble the Upper Mounting Bracket (17) to the Radaitor and Isolator (25) using Nuts (21) and Bolts (23) as shown in Fig. 6. Check the alignment of the fan with the Fan Shroud and make sure it has the appropriate alignment necessary such the fan will not get in contact with the Fan shroud (9).
- 5 Attach the Top Tank Hose (33) and Bottom tank hose (32) into the radiator and to the engine as shown in Fig. 3. using Hose Clamp (38). Route the Top Tank Hose such that it goes through the p-clip (43) to prevent the hose from rubbing with the fan guard. The P-Clip connects with the fan guard using M6 Bolt (50)
- 6 Attach the Upper CAC Piping (30) to the top port of CAC and the turbo inlet using CAC Coupling (36) and Clamps (42). Attach the Lower CAC Piping (31) to the bottom port of CAC and the intake throttle using CAC Coupling (36&37) and
- 7 Clamps (42).
- 8 Assemble the Degas tank (12) in the Radiator assembly using Bolts (23) as shown in Fig. 3.
- 9 Attach the Degas Tank Hose (34) to the Degas Tank Assembly (12) and the Bottom Tank Hose (32) using Hose Clamps (41). Attach the Degas Tank Hose (35) to the Degas Tank Assembly (12). Connect the Hose from the Dosing Module outlet port on the Engine Aftertreatment to the Degas Tank using Hose Clamps and Hose from the KDEF2,3, & 4 kits.
- 10 Tighten all remaining bolts and nuts according to specification in Table 1.
- 10 Add antifreeze, using a 50:50 mixture, into the Radiator. After running the engine for a few minutes, add more antifreeze mixture if necessary.

NOTE: Comply with torque standards in the table to avoid unexpected damage during installation or in the future.

Table 1:d Bolt Tightening Torque			
Diameter x Pitch	N-m	Foot-lbf	Kgf-m
M6 X 1.0	9.8 ~ 11.8	7 ~ 9	1.0 ~ 1.2
M8 X 1.25	22.6 ~ 28.3	17 ~ 21	2.3 ~ 2.9
M12 X 1.75	78.4 ~ 98	58 ~ 72	8 ~ 10
M16 X 1.5	215.7 ~ 235.4	159 ~ 174	22 ~ 24
1/2	77.3 ~ 98.9	57 ~ 73	7.9 ~ 10.1
Radiator Hose Clamps	4.5 ~ 5.1	3.3 ~ 3.8	0.45 ~ 0.52
CAC Hose Clamps	16.2 ~ 24.4	12 ~ 18	1.7 ~ 2.5