



Supplement to Yanmar Kit Installation Instructions

SAFETY

This product is designed and intended only for use with a YANMAR engine. All safety and warning information contained in the Yanmar Operation Manual and Service Manual is adopted and incorporated to apply to the components, accessories, and parts that are utilized with Yanmar engines. Follow all instructions and precautions before installing this product, before operating, during operation, and during periodic maintenance procedures for your safety, the safety of others, and to protect the performance of your engine.



Item	Lev.	O	Part No.	Description	Quantity	Remarks
1	--		129A11-44140	Radiator Assembly	1	
2	--		129987-44570*	Radiator Cap	1	
3	--		129A11-44160	Fan Guard	1	
4	--		129A11-44170	Fan Guard	1	
5	--		129689-44030*	Core Guard	1	
6	--		129A11-44880	PLUG, SHEET METAL, FLUSH, 19.05 DIA. HOLE X 25.	6	
7			129689-44340	Bolt, M5 X 0.8 - 12 (flanged hex head)	16	
8	--		129A11-49070*	Hose, Top Tank	1	
9	--		129A11-49060*	Hose, Bottom Tank	1	
10	--		129689-44070*	Clamp, Hose 21-44 mm OD	1	
11	--		129989-44200	Clamp, Hose 40-64 mm OD	3	
12			129689-44000*	1-Liter Overflow Bottle Assembly	1	
13	--	X	129989-44040	Nut, Lock M8 X 1.25 (Flange hex head)	2	
14	--	X	129689-44110	Bracket, Overflow, 1L	1	
15	--		26106-080122*	Bolt, M8 X 1.25 - 12 (Washer hex head)	2	

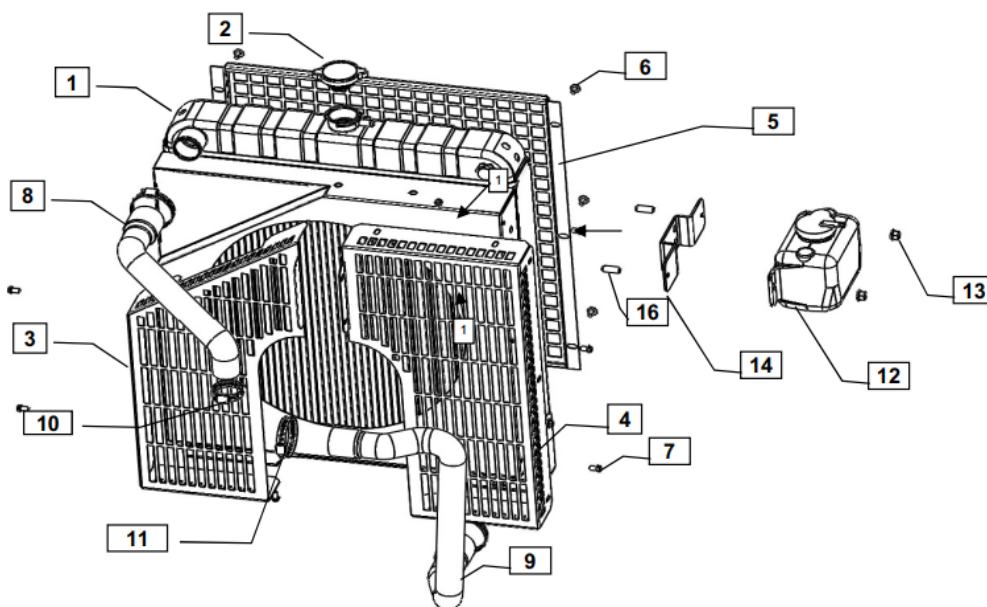

MODELS
3TNV86CT-DYA

Note: Service parts are denoted by an asterisk. To replace non-service parts, the entire kit will need to be purchased.



Installation Instructions

Hand tighten all bolts and nuts until assembly is completed, then torque according to specifications in Table 1. The numbers in () represent the item numbers.

WARNING: DO NOT RUN ENGINE WITHOUT COOLANT IN RADIATOR.

1. Remove Fan Guard (3&4) from Radiator Assembly and place it around the cooling fan on the engine. The fan guard is two piece so it can be installed without removing engine cooling fan, Reinstall the two M5 (7) bolts to reconnect two halves after placing around fan.
2. Install Radiator (1) to the Radiator Mounting Kit using 1/2 X 13 - 2 1/2" bolts and 0.5 X 2.0 X 0.125" washers provided with the Radiator Mounting Kit.
3. Mount Fan Guard (3&4) to the Radiator (1) using M5 X 0.8 - 12mm bolt (7).
4. Using Upper Support and M8 X 1.25 - 16mm bolts from Radiator Mounting Kit, fasten the Radiator (1) to the Upper Mount from the Radiator Mounting Kit.
5. Attach the Top Radiator Hose (8) to the inlet of Radiator (1) and the top of the water pump with Hose Clamps (10). Attach the Bottom Radiator Hose (9) to the outlet of Radiator and the inlet of water pump with Hose Clamps (10 for top water pump connection and all others 11).
6. Adjust the Radiator Assembly and support assembly to align the center of the cooling fan with the center of the Radiator (1). Tighten the Radiator Mounting Kit bolts.
7. Mount Overflow Bottle Assembly (12) to the side of the Radiator (1) using M8 X 1.25 - 12mm bolts (15). Attach the Overflow Hose to the bottom of the overflow bottle and the top of Radiator using hose clamps included with the Overflow Bottle Assembly.
8. Tighten all remaining bolts and nuts according to specification in Table 1.
9. Install Core Guard (5) to the Radiator (1) using the provided 1/4 X 20 - 3/8" bolts (6). Tight to specification provided.
10. Using decals included with overflow bottle, place the LOW sticker on the overflow bottle, second indentation to the bottom. Place the HIGH sticker on the top indentation.
11. Add antifreeze, using a 50:50 mixture, into the Radiator. After running the engine for a few minutes, add more antifreeze mixture if necessary.

NOTE: Comply with torque standards in the table to avoid unexpected damage during installation or in the future.

Diameter x Pitch	Kgf-m	Foot-lbf	N-m
1/4 X 20	0.9 ~ 1.1	6.3 ~ 8.3	8.5 ~ 11.3
M5 X 0.8	0.7 ~ 0.9	4.8 ~ 6.3	6.5 ~ 8.5
M8 X 1.25	1.5 ~ 2.9	10.6 ~ 20.9	14.4 ~ 28.3
1/2 X 13	7.9 ~ 10.1	57 ~ 73	77.3 ~ 98.9