



Supplement to Yanmar Kit Installation Instructions

SAFETY

This product is designed and intended only for use with a YANMAR engine. All safety and warning information contained in the Yanmar Operation Manual and Service Manual is adopted and incorporated to apply to the components, accessories, and parts that are utilized with Yanmar engines. Follow all instructions and precautions before installing this product, before operating, during operation, and during periodic maintenance procedures for your safety, the safety of others, and to protect the performance of your engine.



Item	Lev.	O	Part No.	Description	Quantity	Remarks
1	--		119515-44500*	Radiator Assembly	1	
2	--		129107-44590*	Cap, Radiator	1	
3	--		119515-44600*	Shroud	1	
4	--		26014-060122*	Bolt, M6 X 1 - 12 (Flanged hex head)	4	
5	--		121468-44520*	Sub Tank Assembly	1	
6	--	X	121470-44530*	Sub Tank Body	1	
7	--		121450-44531*	Cap	1	
8	--		124450-44560*	Pipe Retainer	1	
9	--		121470-44581*	Gasket	1	
10	--		23065-070130*	Hose, 7 x 130	1	
11	--		119802-44570*	Fan Guard	1	
12	--		119255-44660*	Rubber, Radiator	2	
13	--		119802-49010*	CW-T (A)	1	
14	--		119802-49020*	CW-T (B)	1	
15	--		129461-59580*	Cap, Fuel Oil	1	
16	--		23000-013000*	Clamp, Hose 13	1	
17	-		23000-035000*	Clamp, Hose 35	4	
18	-		26106-060162*	Bolt, M6 X 1 - 16 (Flanged hex head)	8	

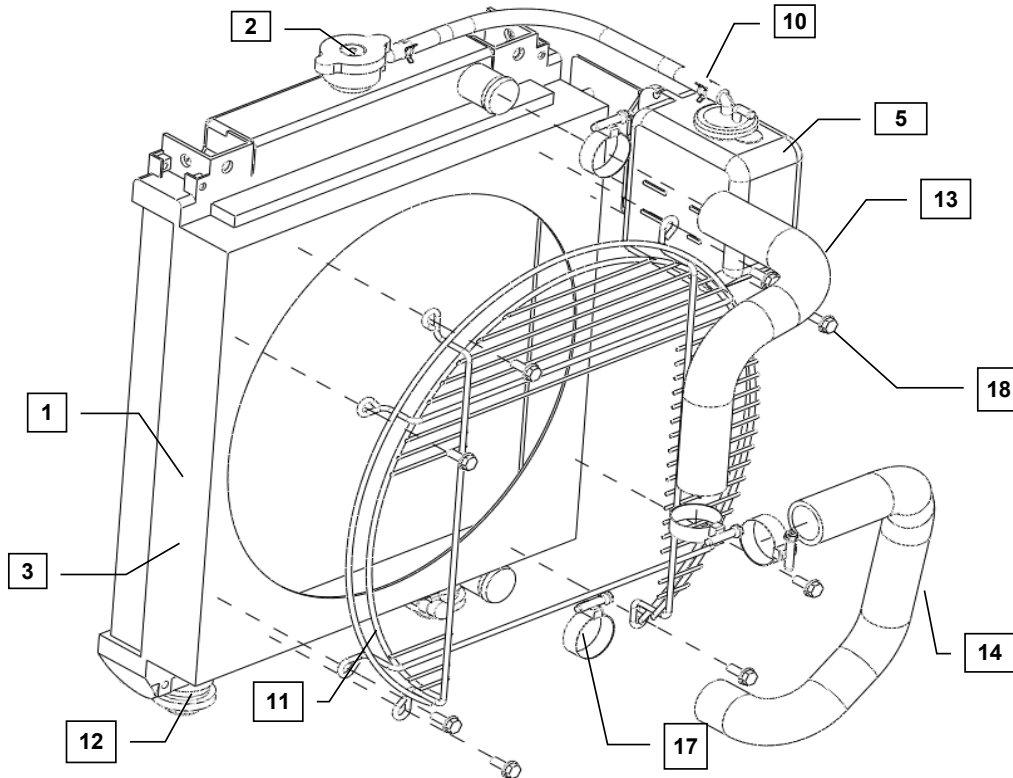

MODELS
3TNM72



Installation Instructions

Hand tighten all bolts and nuts until assembly is completed, then torque according to specifications in Table 1. The numbers in () represent the item numbers.

WARNING: DO NOT RUN ENGINE WITHOUT COOLANT IN RADIATOR.

1. Place the fan guard (11) around the cooling fan before mounting the radiator (1).
2. Install radiator (1) to the vehicle side radiator mount using the rubber isolators (12).
3. Mount the fan guard (11) to the radiator (1) using M6 X 1 - 16mm bolts provided (18).
4. Using the vehicle side upper support, customer supplied rubber isolators, and hardware, fasten the radiator (1) to the vehicle frame.
5. Attach the top radiator hose (14) to the inlet of the radiator (1) and the outlet of the water pump with hose clamps (17). Attach the bottom radiator hose (14) to the outlet of radiator (1) and the inlet of water pump with hose clamps (17).
6. Adjust the radiator assembly and support assembly to align the center of the cooling fan with the center of the radiator (1). Tighten the radiator mounting bolts.
7. Mount overflow bottle assembly (5) to the vehicle frame at this time. Attach the overflow hose to the inlet of the overflow bottle and the top of radiator using hose clamps included with the radiator assembly. Please follow the following precautions when installing the coolant reservoir tank:

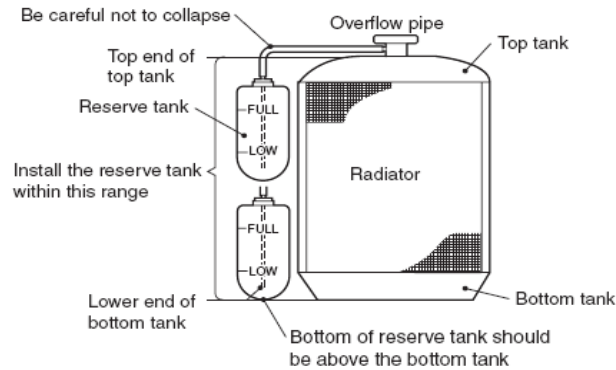

8. Tighten all remaining bolts and nuts according to specification in Table 1.
9. Add antifreeze, using a 50:50 mixture, into the Radiator. After running the engine for a few minutes, add more antifreeze mixture if necessary.

NOTE: Comply with torque standards in the table to avoid unexpected damage during installation or in the future.

TABLE 1:

Diameter x Pitch	Kgf-m	Foot-lbf	N-m
M6 x 1.00	1.0 ~1.2	7.2 ~ 8.6	9.8 ~11.8