



Supplement to Yanmar Kit Installation Instructions

SAFETY

This product is designed and intended only for use with a YANMAR engine. All safety and warning information contained in the Yanmar Operation Manual and Service Manual is adopted and incorporated to apply to the components, accessories, and parts that are utilized with Yanmar engines. Follow all instructions and precautions before installing this product, before operating, during operation, and during periodic maintenance procedures for your safety, the safety of others, and to protect the performance of your engine.



Item	Lev.	O	Part No.	Description	Quantity	Remarks
1	-		119128-07000*	Label, Yanmar	1	
2	-		119028-44510*	Radiator CMP	1	
3	--		119515-44500*	Radiator Assembly	1	
4	---		129107-44590*	Cap, Radiator	1	
5	---		119515-44600*	Shroud	1	
6	---		26014-060122*	Bolt, M6 X 1 - 12 (Flanged hex head)	4	
7	--		119128-44640*	Rubber, Cushion	2	
8	--		119225-44660*	Rubber, Radiator	2	
9	--		119028-44800*	Screen, Radiator	1	
10	--		119028-44890*	Spacer	2	
11	--		119028-44930*	Stay C, Radiator	2	
12	--		119028-44970*	Bracket C, Radiator	1	
13	--		129461-59580*	Cap, Fuel Oil	1	
14	--		23000-013000*	Clamp, Hose 13	1	
15	--		26106-060102*	Bolt, M6 X 1 - 10 (Flanged hex head)	6	
16	--		26106-080122*	Bolt, M8 X 1.25 - 12 (Flanged hex head)	4	
17	--		26106-080352*	Bolt, M8 X 1.25 - 35 (Flanged hex head)	2	
18	--		26366-060002*	Nut, M6 X 1 (Flanged hex head)	2	
19	--		26366-080002*	Nut, M8 X 1.25 (Flanged hex head)	2	
20	-		121468-44520*	Tank Assy, Sub	1	
21	--		121470-44530*	Body, Sub Tank	1	
22	--		121450-44531*	Cap	1	
23	--		124450-44560*	Retainer, Pipe	1	
24	--	X	121470-44581*	Gasket	1	
25	--		23065-070130*	Hose, 7 x 130	1	
26	-		119802-44570*	Guard, Fan	1	
27	-		119128-44640*	Rubber, Cushion	2	
28	-		119128-44901*	Bracket, Sub Tank	1	
29	-		119028-44910*	Stay A, Radiator	1	
30	-		119028-44920*	Stay B, Radiator	1	
31	-		119028-44950*	Bracket, Int. Radiator	1	
32	-		119028-44960*	Bracket, Ex. Radiator	1	
33	-		119802-49010*	CW-T (A)	1	
34	-		119802-49020*	CW-T (B)	1	
35	-		124579-49160*	Pipe, Water Drain	1	
36	-		124766-59050*	Clamp, Hose 12	2	
37	-		119128-77402*	Cover, Alternator	1	
38	-			Mounting Foot	2	*Not Included
39	-		26106-100202*	Bolt, M10 X 1.5 - 20 (Flanged hex head)	4	
40	-		26106-100252*	Bolt, M10 X 1.5 - 25 (Flanged hex head)	4	
41	-		23000-035000*	Clamp, Hose 35	4	
42	-		26106-060162*	Bolt, M6 X 1 - 16 (Flanged hex head)	8	
43	-		26106-060162*	Bolt, M6 X 1 - 16 (Flanged hex head)	2	
44	-		26106-060122*	Bolt, M6 X 1.25 - 12 (Flanged hex head)	4	
45	-		26106-080122*	Bolt, M8 X 1.25 - 12 (Flanged hex head)	2	
46	-		26366-060002*	Nut, M6 X 1 (Flanged hex head)	6	

*Not Included - See kit matching table (KF6 or KF6V needed)

Note: Service parts are denoted by an asterisk. To replace non-service parts, the entire kit will need to be purchased.

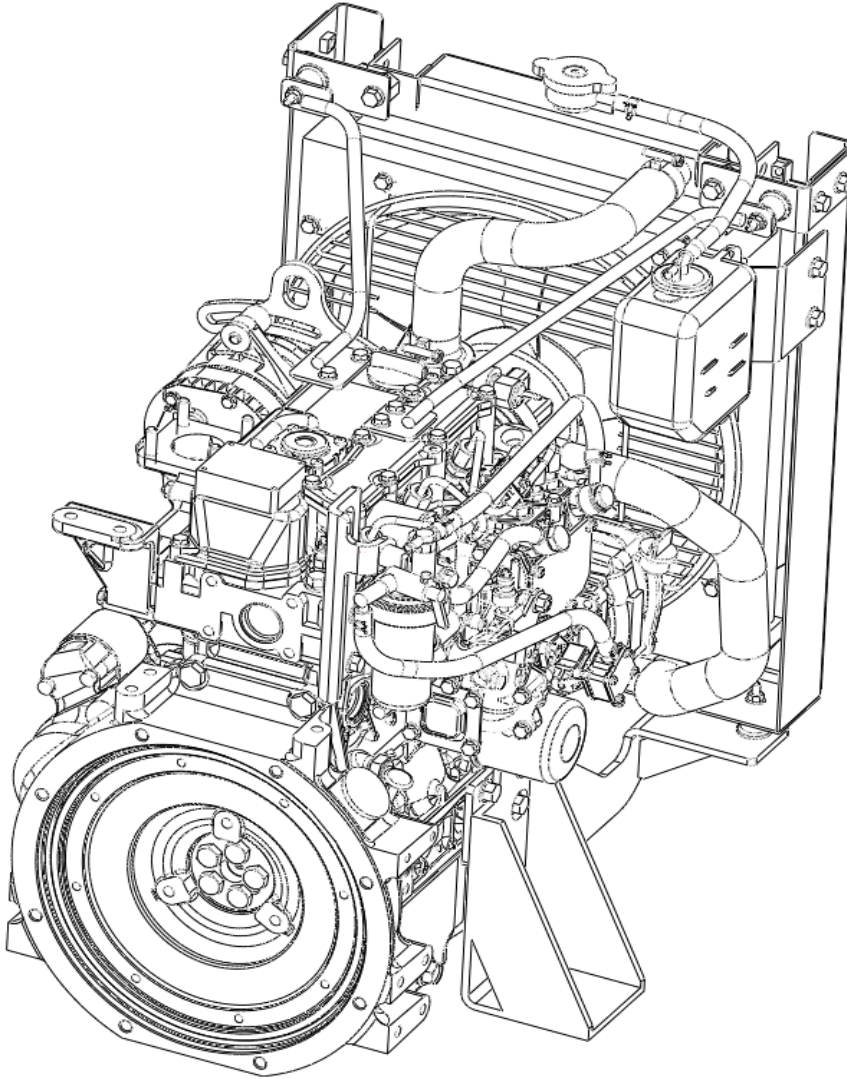

MODELS

3TNM72
3TNM74F

* KF6 Engine feet shown. KF6V engine feet also available depending on engine model

CAUTION: If using the 3TNM72/3TNM74F engines at rated speed and power, especially at ambient temperatures $\geq 100^{\circ}\text{F}/38^{\circ}\text{C}$, YANMAR strongly recommends the use of the KR13A for more effective cooling performance.



Installation Instructions

Hand tighten all bolts and nuts until assembly is completed, then torque according to specifications in Table 1. The numbers in () represent the item numbers.

WARNING: DO NOT RUN ENGINE WITHOUT COOLANT IN RADIATOR.

1. Fasten the intake and exhaust side lower radiator support brackets (31,32) to the front engine mounting pads with M10 X 1.5 - 20mm bolts (39) according to the picture.

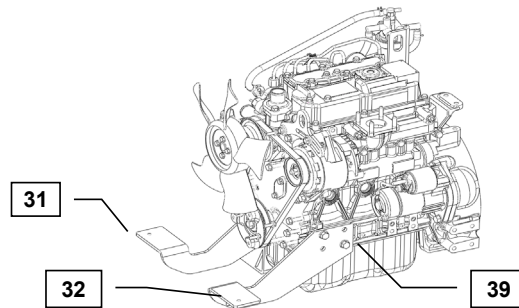

2. Fasten each engine foot (38) to the front engine mounting pad with the M10 X 1.5 - 25mm bolts provided (40). KF6 engine foot shown.

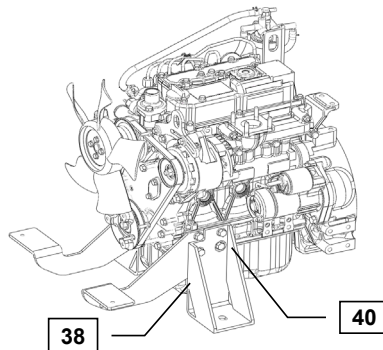

3. Fasten the exhaust side upper support bracket (29) to the exhaust side of the cylinder head with the M6 X 1 - 12mm bolts provided (44). Fasten the intake side upper support bracket (30) to the top face of the intake manifold with the M6 X 1 - 12mm bolts provided (44).

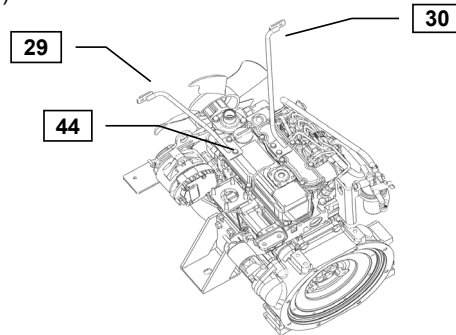



4. Fasten the isolator mounts (27) to the all four mounting locations on the radiator assembly (2) with the M6 X 1.00 nuts provided (46).

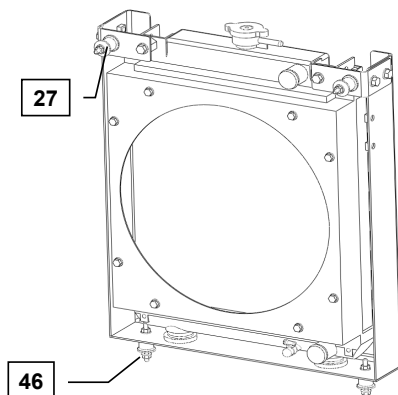

5. Remove the fan guard (26) from the radiator assembly and place it around the cooling fan.

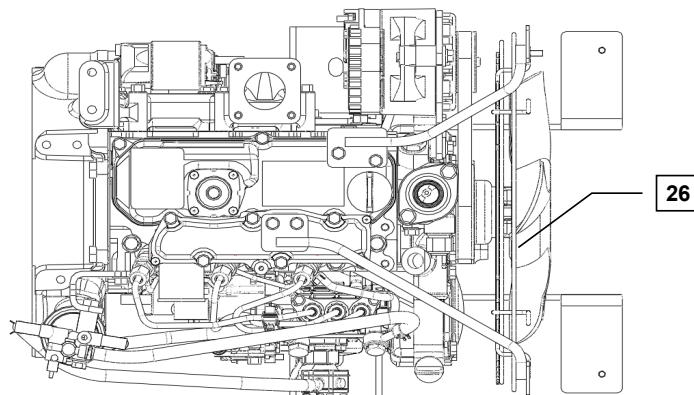

6. Install the pre-assembled radiator (2) to the lower radiator mounting brackets using the rubber isolators and M6 X 1.00 nuts (46) provided with the radiator kit.
7. Mount the fan guard (26) to the radiator sub-assembly (2) using M6 X 1 - 16mm bolts provided (42).
8. Fasten the upper support brackets (29,30) to the upper rubber isolators (27) with the M6 X 1.00 nuts (46).
9. Attach the top radiator hose (33) to the inlet of the radiator (2) and the outlet of the water pump with hose clamps (41). Attach the bottom radiator hose (34) to the outlet of radiator and the inlet of water pump with hose clamps (41).



10. Mount overflow bottle assembly (20) to the side of the radiator (2) using M8 X 1.25 - 12mm bolts (45). Attach the overflow hose to the inlet of the overflow bottle and the top of radiator using hose clamps included with the overflow bottle

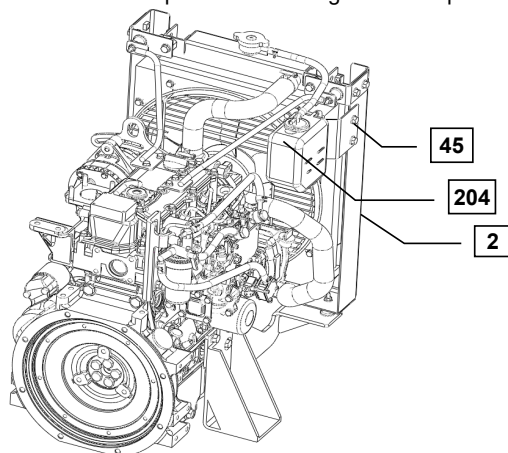

11. Option: To add the alternator cover (37) remove the existing alternator fasteners and add the cover according to the image.

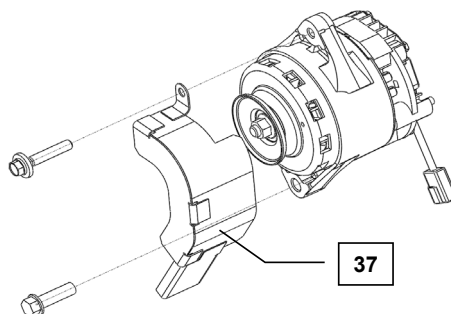

12. Tighten all remaining bolts and nuts according to specification in Table 1.
13. Add antifreeze, using a 50:50 mixture, into the Radiator. After running the engine for a few minutes, add more antifreeze mixture if necessary.

NOTE: Comply with torque standards in the table to avoid unexpected damage during installation or in the future.

TABLE 1:

Diameter x Pitch	Kgf-m	Foot-lbf	N-m
1/4 X 20	0.9 ~ 1.1	6.3 ~ 8.3	8.5 ~ 11.3
M5 X 0.8	0.7 ~ 0.9	4.8 ~ 6.3	6.5 ~ 8.5
M6 x 1.00	1.0 ~ 1.2	7.2 ~ 8.6	9.8 ~ 11.8
M8 x 1.25	1.5 ~ 2.9	10.6 ~ 20.9	14.4 ~ 28.3
M10 x 1.50	4.5 ~ 5.5	32.5 ~ 39.8	44.0 ~ 54.0
1/2 X 13	7.9 ~ 10.1	57 ~ 73	77.3 ~ 98.9