



## Supplement to Yanmar Kit Installation Instructions

# SAFETY

---

This product is designed and intended only for use with a YANMAR engine. All safety and warning information contained in the Yanmar Operation Manual and Service Manual is adopted and incorporated to apply to the components, accessories, and parts that are utilized with Yanmar engines. Follow all instructions and precautions before installing this product, before operating, during operation, and during periodic maintenance procedures for your safety, the safety of others, and to protect the performance of your engine.



Item	Part No.	Description	Quantity	Remarks
1	129G88-91400	Main Harness Assembly	1	
2	129G88-91010	Harness, ECU	1	
3	172B02-17150*	80A, 12V Relay	2	Included w/ harness
4	-	Starter Sub Harness	1	Included w/ harness

**MODELS**  
4TN107FTT

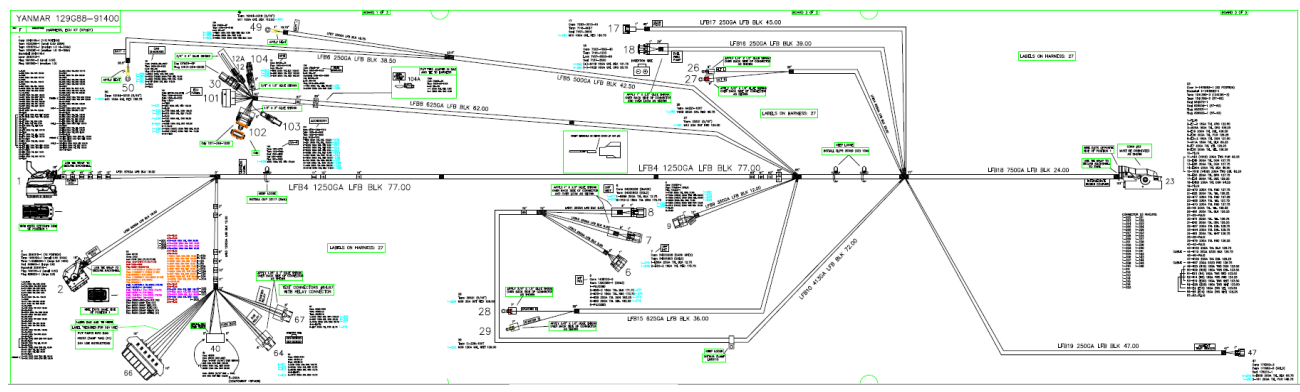

**NOTE:** Starter Sub Harness may not be necessary; Starter type will determine  
Service parts are denoted by an asterisk. To replace non-service parts, the entire kit will need to be purchased.  
PAGE 1 OF 5

**KPH21 - Harness KIT**  
**INS-KPH21-0011**



## Installation Instructions

NOTE: The optional connections for distributor use are located in the Accessory Coupler. The optional features include Pre-Heat Lamp, Engine Stop 1 & 2, Charge Lamp, etc.

Please see the next page for detailed installation instructions.

WARNING: Be sure battery cables are connected correctly. Disconnecting either the positive or negative battery cable while the equipment is operating will cause premature failure of electronic components. Also, never weld on equipment with the ECU connected to the wire harness.

NOTE: In the event that the wire harness needs to be extended, never use scotch locks or butt connectors to extend the wire harness. All extended wires must be soldered and sealed.

### Remote Mounted ECU Applications:

For applications that remotely mount the ECU within the wire harnesses reach please use the following ECU mounting guidelines:

- 1- Install the ECU in a location that is not subject to steam or high-pressure water for cleaning
- 2- Install the ECU in a location that is well ventilated and not subject to direct sunlight.
- 3- Install the ECU so that the connector faces downward. Failure to do so may trap water in the connector, resulting in corrosion of connector pins.
- 4- Ensure no water is trapped inside the connector when plugging the connector. Water inside the connector may corrode connector pins, resulting in malfunctioning of the ECU.

Refer to harness drawing for additional design requirements for consideration of application. A troubleshooting guide is available through Yanmar's Distributor Website or by contacting Yanmar America's Service Department.

Table 1: Comply with torque standards in the table to avoid unexpected damage during installation or in the future.

Diameter x Pitch	Kgf-m	Foot-lbf	N-m
M5x0.8	0.4 ~ 0.7	3 ~ 5	4 ~ 6.7
M6 x 1.0	1.0~1.2	7 ~ 9	9.8 ~ 11.8
M8 x 1.25	1.5 ~ 2.9	10.6 ~ 20.9	22.6 ~ 28.4

Note: There are no bolts included with harness kit

**KPH21 - Harness KIT**  
**INS-KPH21-0011**

## Harness Routing Instructions

1. Lay the loose harness on engine to gauge fitment and placement of where the relays, ECU, and connectors should go based on the wiring diagrams provided. Please refer to TNV application manual for cautionary measures to be taken when mounting a harness to an engine.
2. The intermediate coupler should be connected at first. Secure section of loom containing (2) P-clips to the M10 threaded holes (*Blue dots on the red line*) on the engine block just below the intermediate coupler with loosely attached P-clips. Route the main stem through the top of Flywheel Housing as shown by the red curve below.

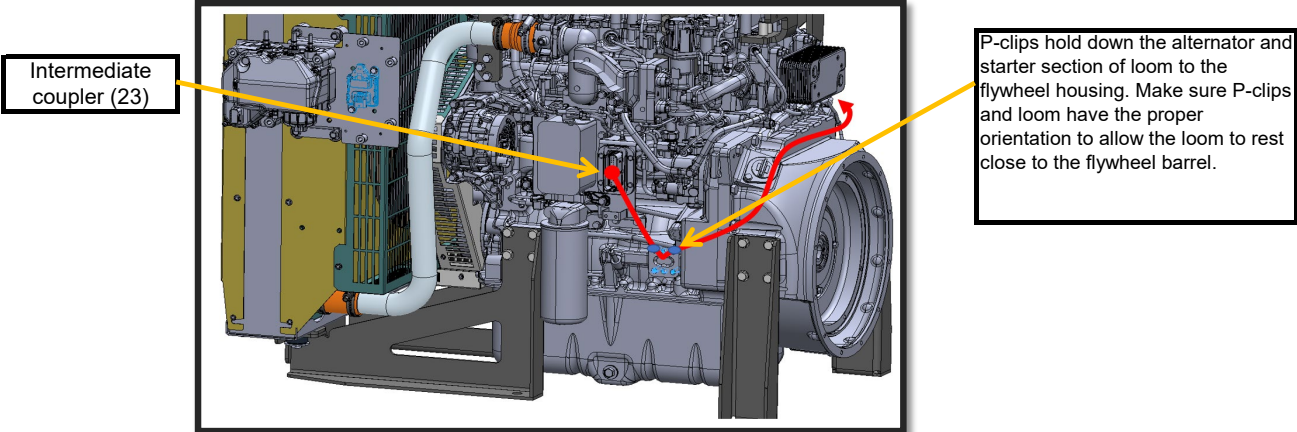

3. Connect alternator plugs (26) & (27) and starter connectors (28) & (29).

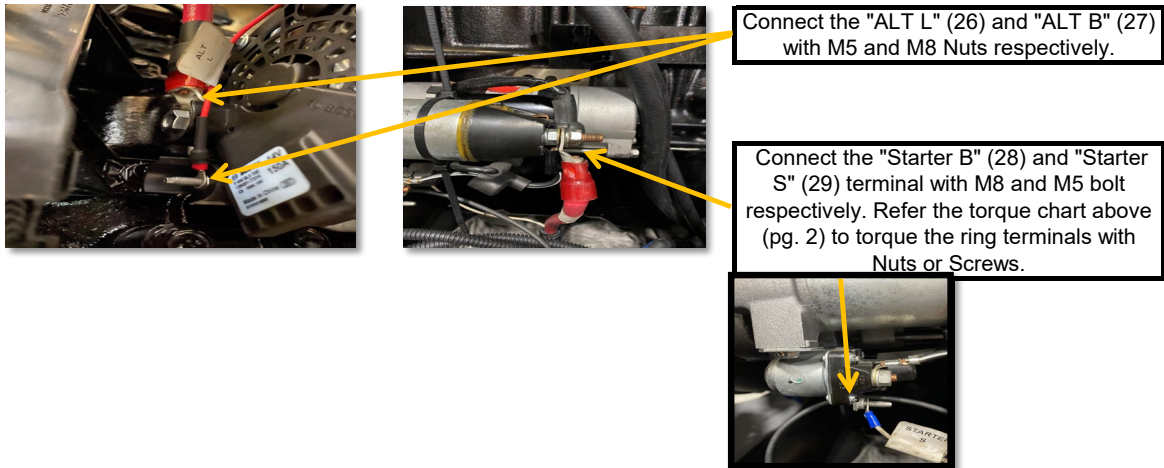

4. Layout harness as shown. Connectors 1, 2, 66, 40, 64, 67, 30, 12, 101 - 104, and the battery leads (49 & 50).





## Harness Routing Instructions

5. Connect glow plug (17). Always avoid harness contact with high temp surfaces such as the DPF, EGR, etc. To avoid harness from touching high temp surfaces, and touching the ground, always tie excess looms of harness with zip tie wherever possible.

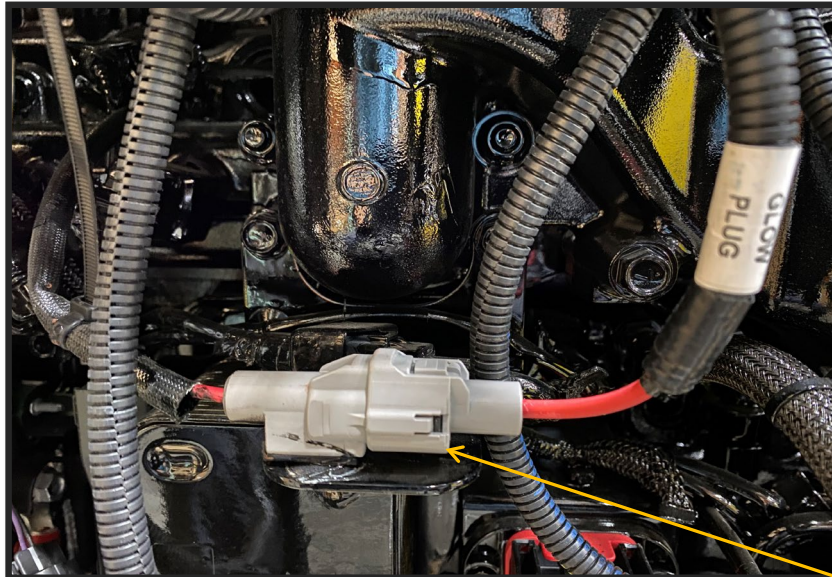

Glow Plug

6. Now route the DPF/SCR branch up to the DPF & SCR connections. Check and adjust with zip tie if necessary to ensure that no contact will be made in operation between harness and high temp surfaces eg: DPF, SCR, EGR etc.

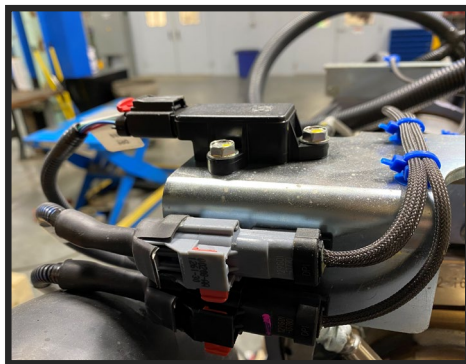

Refer to harness drawing for additional design requirements for consideration of application.

## Harness Routing Instructions

- 7 Connect the panel connection (101) to the panel and ensure the twist lock is engaged
- 8 Connect machine side Regeneration interlock to the interlock connection (104) or if utilizing the provided jumper please install
- 9 Install the relays provided as loose parts with the engine into the harness (64,67). Be sure to install in such a way to prevent water intrusion.
- 10 Install the battery ring terminals (49,50) onto the proper battery terminals.
- 11 Connect the connector (1) and (2) to the ECU and ensure the harness is clamped within 300 mm from the connector.

