



Supplement to Yanmar Kit Installation Instructions

SAFETY

This product is designed and intended only for use with a YANMAR engine. All safety and warning information contained in the Yanmar Operation Manual and Service Manual is adopted and incorporated to apply to the components, accessories, and parts that are utilized with Yanmar engines. Follow all instructions and precautions before installing this product, before operating, during operation, and during periodic maintenance procedures for your safety, the safety of others, and to protect the performance of your engine.



Item	Lvl	Part No.	Description	Quantity	Remarks
1	--	128300-13230*	GASKET, SILENCER	2	
2	--	129G90-13360	PIPE ASSY, EXHAUST	1	
3	--	129F01-13660*	BOLT, M10X30 10.9T	4	
4	--	26306-100002*	NUT, 10	4	

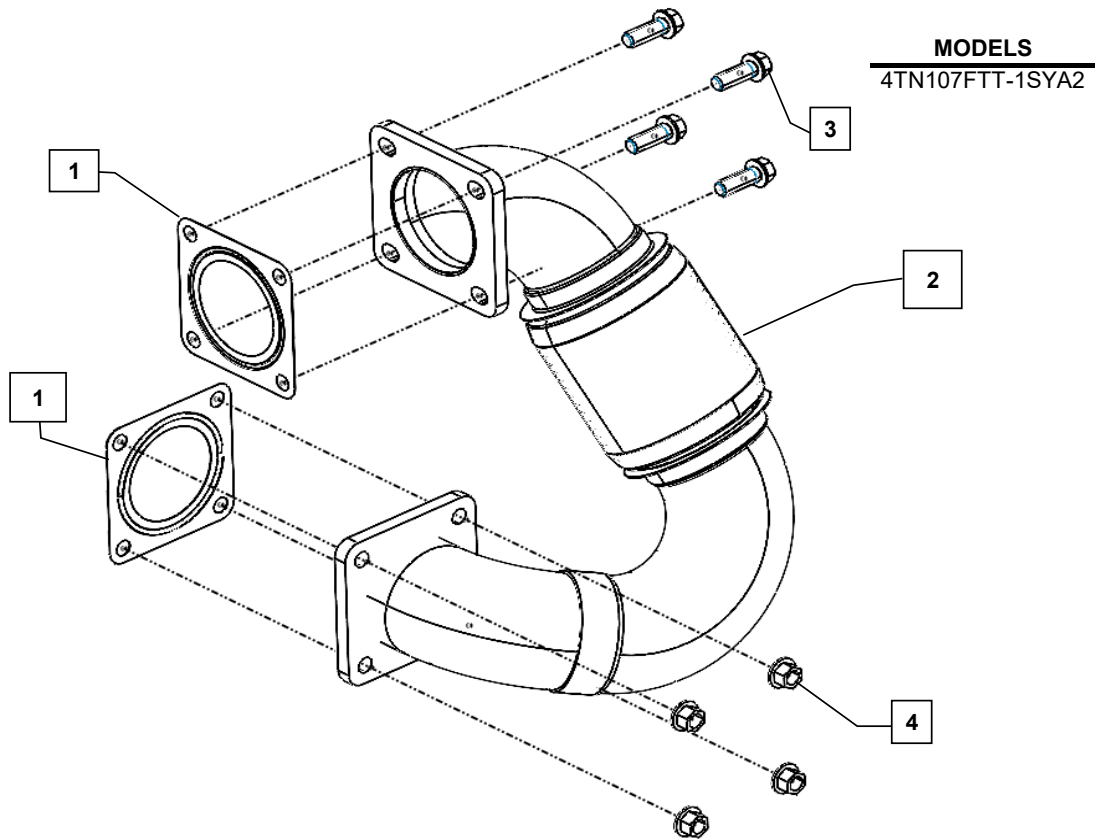

Note: Service parts are denoted by an asterisk. To replace non-service parts, the entire kit will need to be purchased.



Installation Instructions

WARNING: DO NOT INSTALL KIT WHILE THE ENGINE IS STILL HOT!

Hand tighten all bolts and nuts until assembly is completed, then torque according to specifications in Table 1.

1. Place the Gaskets (1) provided in loose parts box on the aftertreatment (ATD) inlet flange and on the turbo outlet flange.
2. Connect and fasten one end of the Exhaust pipe (2) to the ATD inlet flange using M10X30 Bolts (3) with torque values provided in Tabel 1.
3. Connect and fasten the other end of the Exhaust pipe (2) to the turbo outlet flange using M10 Nuts (4) with torque values provided in Tabel 1.

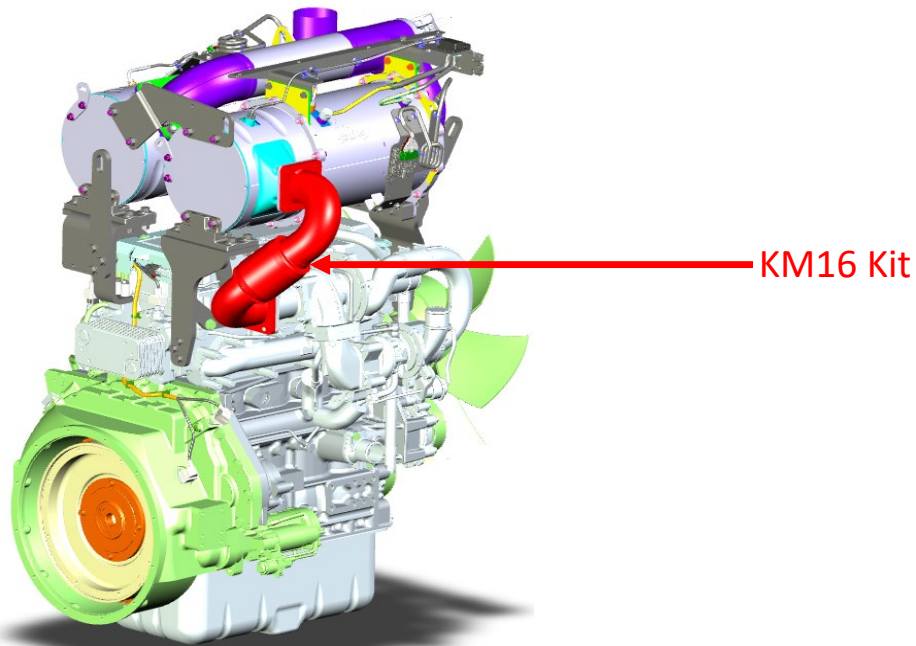

NOTE: Comply with torque standards in the table to avoid unexpected damage during installation or in the future.

Table 1: Proper torque specifications for bolts and nuts.

Diameter x Pitch	Kgf-m	Foot-lbf	N-m
M8 x 1.25	1.5 ~ 2.9	10.6 ~ 20.9	14.4 ~ 28.3
M10 x 1.5	4.5 ~ 5.5	33 ~ 40	44.1 ~ 53.9
M12 x 1.75	8.0 ~ 10	58 ~ 72	78.4 ~ 98.0