



Supplement to Yanmar Kit Installation Instructions

## SAFETY

---

This product is designed and intended only for use with a YANMAR engine. All safety and warning information contained in the Yanmar Operation Manual and Service Manual is adopted and incorporated to apply to the components, accessories, and parts that are utilized with Yanmar engines. Follow all instructions and precautions before installing this product, before operating, during operation, and during periodic maintenance procedures for your safety, the safety of others, and to protect the performance of your engine.



Item	Part No.	Description	Quantity	Remarks
1	129240-13550*	Silencer	1	
2	129689-13530	Bracket, Muffler	1	
3	26106-120252*	Bolt, M12 x 1.25 - 25	2	
4	26366-120002*	Nut, M12 x 1.25	2	
5	26106-100202*	Bolt, M10 x 1.5 - 20	3	
6	129004-13200*	Gasket, Muffler	1	
7	119840-13150*	Pipe, Extension	1	
8	119823-13600*	Stud, M8 x 1.25 - 70	2	
9	119131-18320*	Stud, M8 x 1.25 - 22	2	
10	26306-080002*	Nut, M8 X 1.25 (Flanged hex head)	6	

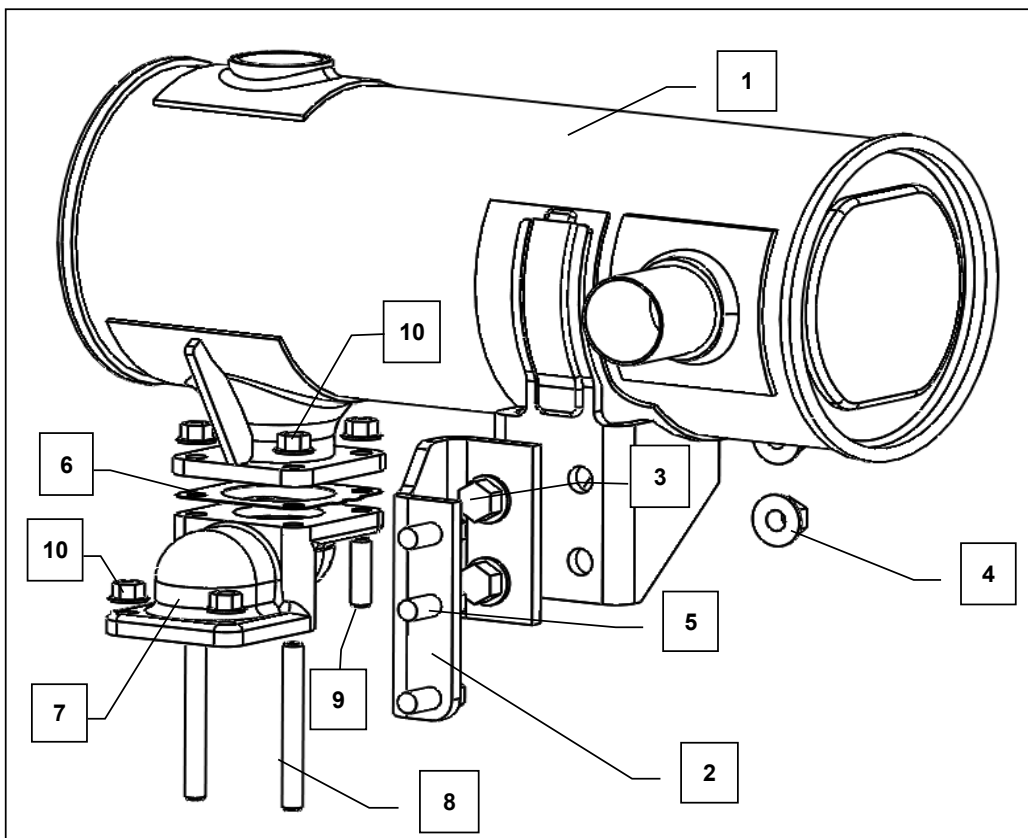

**MODELS**  
3TNV88F-ESGY

Note: Service parts are denoted by an asterisk. To replace non-service parts, the entire kit will need to be purchased.



## Installation Instructions

**NOTE:**

TWO STUDS INCLUDED ON THE ENGINE ON UPPER PORTION OF EXHAUST MANIFOLD MUST BE CHANGED BEFORE FURTHER INSTALLATION. FOLLOW DIRECTIONS BELOW.

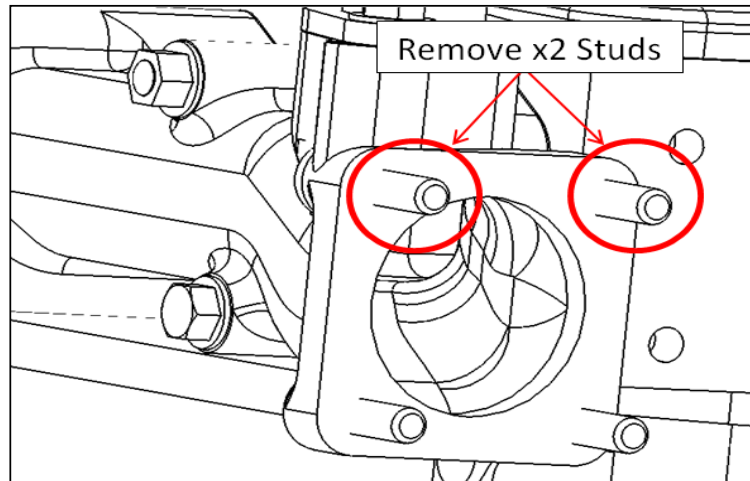

Picture 1. Stud Removal

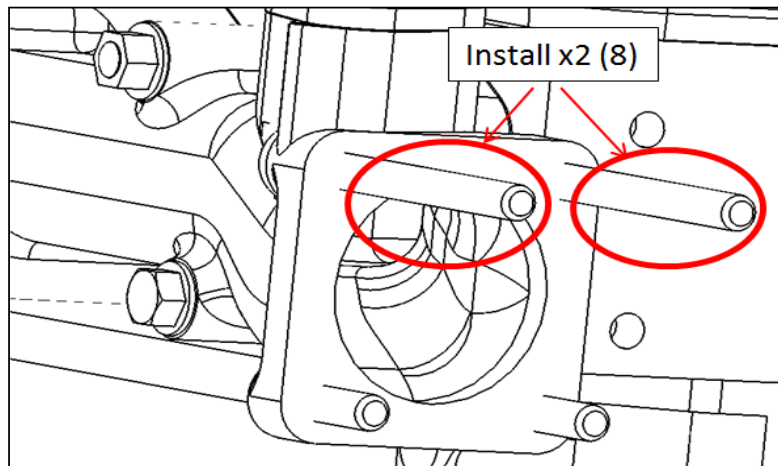

Picture 2. Stud Installation



## Installation Instructions

### WARNING: DO NOT INSTALL KIT WHILE THE ENGINE IS STILL HOT!

Hand tighten all bolts and nuts until assembly is completed, then torque according to specifications in Table 1.

1. Remove top studs from the exhaust manifold, as seen in Picture 1. Replace with updated studs (8), as seen in Picture 2, and torque to M8 standard mentioned in Table 1. Add Exhaust Gasket from engine loose parts.
2. Place Pipe Extension (7), Gasket (6), and Silencer (1), onto the studs (8) connected to the exhaust manifold and fasten with nuts (10) to torques specified in Table 1, as seen in Picture 3.
3. Insert studs (9) into Pipe Extension Flange, and fasten with nuts (10) to torques specified in Table 1, as seen in Picture 3.
4. Connect Muffler Bracket (2) to Silencer mount, and tighten down with bolts (3) and nuts (4) to specified torques in Table 1, as seen in Picture 3.
5. Fasten Muffler Bracket to engine with bolts (5), as seen in Picture 3, to specified torques in Table 1.

**Table 1: Proper torque specifications for bolts and nuts.**

Diameter x Pitch	Kgf-m	Foot-lbf	N-m
M8 x 1.25	1.5 ~ 2.9	10.6 ~ 20.9	14.4 ~ 28.3
M10 x 1.5	4.5 ~ 5.5	33 ~ 40	44.1 ~ 53.9
M12 x 1.75	8.0 ~ 10	58 ~ 72	78.4 ~ 98.0