



Supplement to Yanmar Kit Installation Instructions

SAFETY

This product is designed and intended only for use with a YANMAR engine. All safety and warning information contained in the Yanmar Operation Manual and Service Manual is adopted and incorporated to apply to the components, accessories, and parts that are utilized with Yanmar engines. Follow all instructions and precautions before installing this product, before operating, during operation, and during periodic maintenance procedures for your safety, the safety of others, and to protect the performance of your engine.



Item	Part No.	Description	Quantity	Remarks
1	119749-13590*	Adaptor	2	
2	119515-13200*	Gasket, Muffler	2	
3	26306-080002*	Nut, M8 x 1.25 (Flanged hex head)	8	
4	26106-080352*	Bolt, M8 x 1.25 - 35 (Flanged hex head)	4	

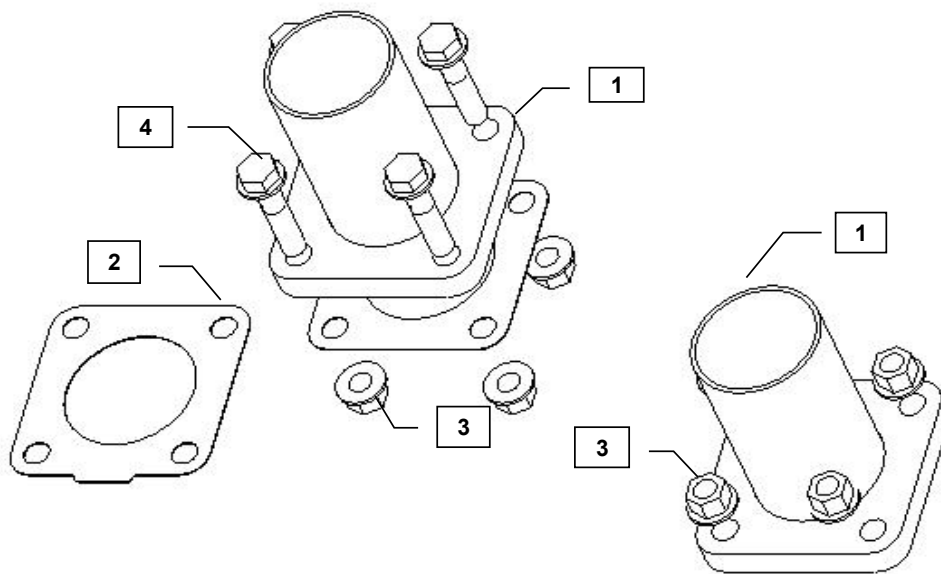

MODELS

2TNV70
3TNM68

Note: Service parts are denoted by an asterisk. To replace non-service parts, the entire kit will need to be purchased.

Remarks:



Installation Instructions

WARNING: DO NOT INSTALL THE KIT WHILE THE ENGINE IS STILL HOT

Hand tighten all bolts and nuts until the assembly is completed, then torque to the specifications in Table 1 below.

1. Place the exhaust gasket included with the engine onto the exhaust manifold flange.
2. Place the Muffler Adaptor (1) on the exhaust manifold flange and secure on the studs using the M8x1.25 Flange Nuts (3).
3. Use the second Adaptor in conjunction with desired Muffler kit.
4. Use the provided M8x1.25 Flange nuts, the Gasket (2), and the M8x1.25 - 35 bolts to secure the second Adaptor (1) to the desired muffler.
5. Use appropriate flexible exhaust tubing and clamps to connect the Adaptors. Yanmar does not provide this tubing.

Table 1: Proper torque specifications for bolts and nuts.

Diameter x Pitch	Kgf-m	Foot-lbf	N-m
M8 x 1.25	1.5 ~ 2.9	10.6 ~ 20.9	14.4 ~ 28.3