



Supplement to Yanmar Kit Installation Instructions

SAFETY

This product is designed and intended only for use with a YANMAR engine. All safety and warning information contained in the Yanmar Operation Manual and Service Manual is adopted and incorporated to apply to the components, accessories, and parts that are utilized with Yanmar engines. Follow all instructions and precautions before installing this product, before operating, during operation, and during periodic maintenance procedures for your safety, the safety of others, and to protect the performance of your engine.

#REF!



Item	Part No.	Description	Quantity	Remarks
1	119810-13100*	Manifold, Exhaust	1	
2	119810-13110*	Gasket, Manifold	1	
3	129004-13200*	Gasket, muffler	1	
4	119802-13740*	Stud bolt, M8x1.25 - 60	2	
5	119131-18320*	Stud, M8 x 1.25 - 22	4	
6	26306-080002*	Nut, M8x1.25 (Flanged hex head)	2	

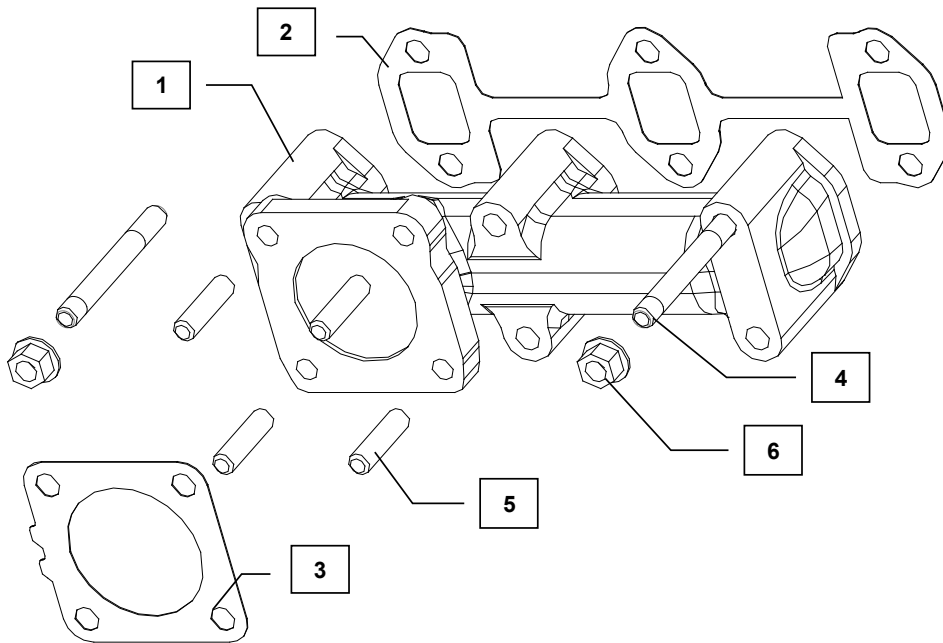

MODELS
3TNV82A-GGE
3TNV82A-DSA
3TNV82A-DSA2
3TNV82A-DSA3
3TNV82A-BDSA
3TNV82A-BDSA2
3TNV82A-BDSA3

Note: Service parts are denoted by an asterisk. To replace non-service parts, the entire kit will need to be purchased.



Installation Instructions

WARNING: DO NOT INSTALL THE KIT WHILE THE ENGINE IS STILL HOT

Hand tighten all bolts and nuts until the assembly is completed, then torque to the specifications in Table 1 below.

1. Remove existing manifold and make sure head surface is free of debris.
2. Install M8x1.25 - 80 Studs (4) in the top left and bottom right so the Manifold Gasket (2) and Exhaust Manifold (1) can be hung on them for fastening.
3. Place the Manifold Gasket (2) over the installed Studs (4)
4. Place the Exhaust Manifold (1) over the Manifold Gasket (2)
5. Install additional M8x1.25 bolts from previous manifold along with the provided M8x1.25 Flanged Nuts (6)
6. Tighten in a cross or star pattern to apply even clamp load on the Manifold Gasket (2), tighten to spec listed in Table 1 below.
7. Install M8x1.25 - 22 Studs (5) in exhaust flange to receive exhaust piping.

Table 1: Standard nuts and bolts tightening torque

Diameter x Pitch	Kgf-m	Foot-lbf	N-m
M6 x 1.0	1.7 - 1.9	12.3 - 13.7	16.7 - 18.6
M8 x 1.25	3.0 - 3.2	21.7 - 23.1	29.4 - 31.4
M10 x 1.50	4.5 ~ 5.5	32.5 ~ 39.8	44.0 ~ 54.0
M12 x 1.75	8.0 ~ 10.0	57.8 ~ 72.3	78.4 ~ 98.0