



## Supplement to Yanmar Kit Installation Instructions

# SAFETY

---

This product is designed and intended only for use with a YANMAR engine. All safety and warning information contained in the Yanmar Operation Manual and Service Manual is adopted and incorporated to apply to the components, accessories, and parts that are utilized with Yanmar engines. Follow all instructions and precautions before installing this product, before operating, during operation, and during periodic maintenance procedures for your safety, the safety of others, and to protect the performance of your engine.



Item	Part No.	Description	Quantity	Remarks
1	129689-08020	Leg, Flywheel Housing Mount	2	
2	22137-100000	Washer, M10 (Plain)	8	
3	26106-100252	Bolt, M10x1.5-25 (Flanged Hex Head)	8	

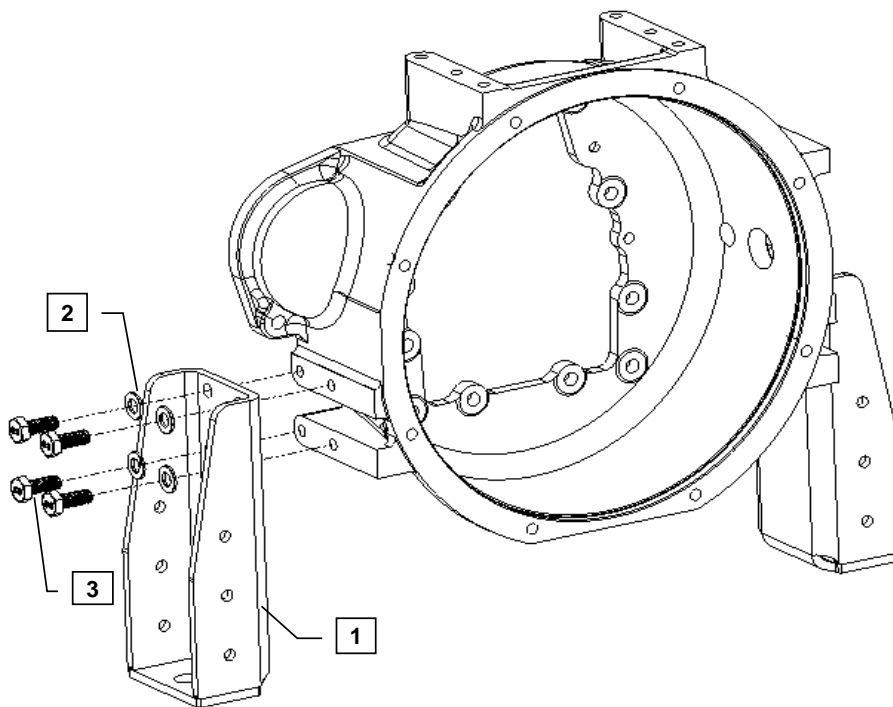

**MODELS**

3TNV84T  
3TNV88  
4TNV84T  
4TNV88

Note: Service parts are denoted by an asterisk. To replace non-service parts, the entire kit will need to be purchased.



---

---

## Installation Instructions

---

---

The flywheel housing leg kit has been designed so each leg can be mounted on the flywheel housing mounting pads only.

Hand tighten all bolts and nuts until assembly is completed, then torque according to specifications in Table 1.

The numbers in () below reference the item numbers on page 1.

1. Install Mounting Legs (1) to flywheel housing mounting pads using Washer (2) and M10 x 1.5 - 25 bolt (3) provided in kit. Bolts used to mount shipped engines are the same size but not long enough and should not be used.

**Table 1: Comply with torque standards in the table to avoid unexpected damage during installation or in the future.**

Diameter x Pitch	Kgf-m	Foot-lbf	N-m
M8 x 1.25	1.5 ~ 2.9	10.6 ~ 20.9	14.4 ~ 28.3
M10 x 1.50	4.5 ~ 5.5	32.5 ~ 39.8	44.0 ~ 54.0
M12 x 1.75	8.0 ~ 10.0	57.8 ~ 72.3	78.4 ~ 98.0