



Supplement to Yanmar Kit Installation Instructions

SAFETY

This product is designed and intended only for use with a YANMAR engine. All safety and warning information contained in the Yanmar Operation Manual and Service Manual is adopted and incorporated to apply to the components, accessories, and parts that are utilized with Yanmar engines. Follow all instructions and precautions before installing this product, before operating, during operation, and during periodic maintenance procedures for your safety, the safety of others, and to protect the performance of your engine.



Item	Part No.	Description	Quantity
1	129987-08000*	Bracket, ECU	1
2	26106-100752*	Bolt, M10x1.5-75 (Flanged Hex Head)	3
3	22137-100000*	Washer, M10 (Plain)	3
4	26106-080302*	Bolt, M8x1.25-30 (Flanged Hex Head)	3
5	22137-080000*	Washer, M8 (Plain)	3

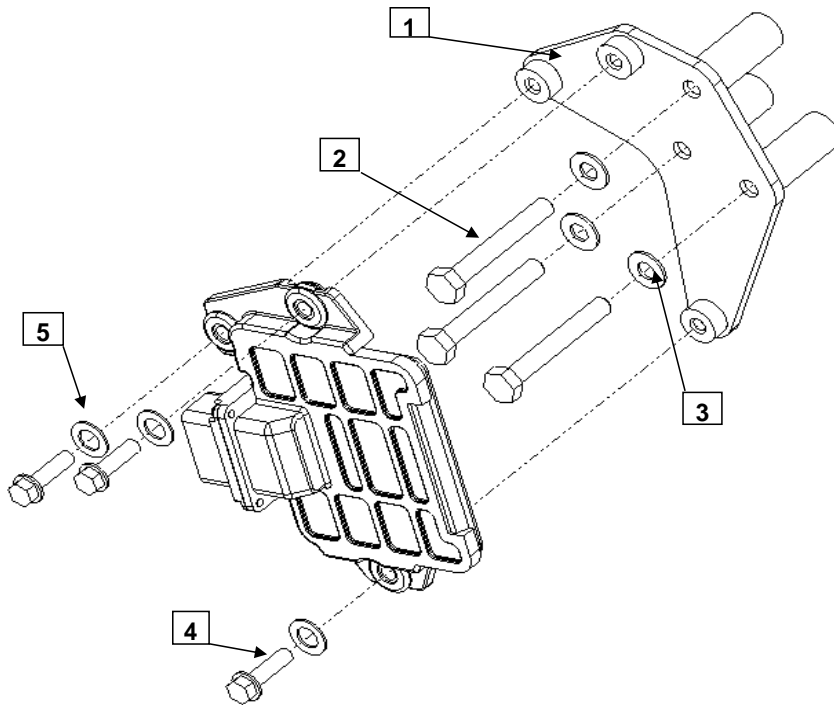

MODELS

3TNV84T-Z
3TNV88-Z
4TNV84T-Z
4TNV88-Z
4TNV98-Z
4TNV98T-Z

Note: Service parts are denoted by an asterisk. To replace non-service parts, the entire kit will need to be purchased.



Installation Instructions

NOTE: Kit #KECUB1A can be installed with or without the kit foot. This kit is intended to mount below the starter to the mounting pad for the kit foot.

Step #1 Installation of the ECU Bracket-

Hand tighten all three M 10 x 1.5 - 75 ECU Bracket Mounting Bolts (2) with Washers (3) until assembly is completed, then torque according to specifications in Table 1.

Step #2 Installation of the ECU-

Hand tighten all three M8 x 1.25 - 30 ECM Mounting Bolts (4) with Washers (5) until assembly is completed, then torque according to specifications in Table 1.

NOTE: Comply with torque standards in the table to avoid unexpected damage during installation or in the future.

Table 1: Standard Nut and Bolt Tightening Torque			
Diameter x Pitch	Kgf-m	Foot-lbf	N-m
M8 x 1.25	1.5 ~ 2.9	10.6 ~ 20.9	14.4 ~ 28.3
M10 x 1.50	4.5 ~ 5.5	32.5 ~ 39.8	44.0 ~ 54.0
M12 x 1.75	8.0 ~ 10.0	57.8 ~ 72.3	78.4 ~ 98.0