



Supplement to Yanmar Kit Installation Instructions

SAFETY

This product is designed and intended only for use with a YANMAR engine. All safety and warning information contained in the Yanmar Operation Manual and Service Manual is adopted and incorporated to apply to the components, accessories, and parts that are utilized with Yanmar engines. Follow all instructions and precautions before installing this product, before operating, during operation, and during periodic maintenance procedures for your safety, the safety of others, and to protect the performance of your engine.



Item	Lev	Part No.	Description	Quantity	Remarks
1	-	129G90-19020	DEF Kit, KDEF3	1	
2	--	129G88-19200*	DEF Tank, 5-gallon	1	
3	--	129F88-19400*	Coolant Control Valve	1	
4	--	129F88-19600*	Hose, 3/8" ID, Supply Line	1	
5	--	129F88-19610*	Hose, 3/8" ID, Return Line	1	
6	--	129G88-19620*	Hose, 5/16" ID, Pressure Line	1	
7	--	129G90-19640	Hose, 3/8" ID, Engine Block to Tee, 15.7"	1	
8	--	129G90-19640	Hose, 3/8" ID, Tee to Dosing Module, 51.2"	1	
9	--	129F88-19710	Hose, 1/2" ID, DEF tank to Engine Water pump, 70.9"	1	
10	--	129F88-19710	Hose, 1/2" ID, Tee to Coolant control valve, 68.6"	1	
11	--	129F88-19710	Hose, 1/2" ID, Coolant control valve to DEF tank, 9.1"	1	
12	--	23000-022000*	Clamp, Hose	10	
13	--	26106-080162*	Bolt, M8-1.25 X 16	4	
14	--	26306-080002*	Nut, M8-1.25	4	
15	--	129G90-19800*	Tee Fitting	1	
16	---	129F88-19850*	Assy, Supply Module Bracket	1	
17	----	129F88-19410	Isolator, Double Stud	4	
18	----	129F88-19420	Hex Nut, 5/16-18	4	
19	----	129689-44880*	Isolator, M8-1.25	4	
20	----	129689-44290*	Bolt, M8-1.25X16	4	
21	----	119E34-12830	Bolt, M8-1.25X30	5	
22	----	129F88-19430	Bolt, Hex cap, M5-0.8X8	2	
23	--	26106-080852*	Bolt, M8X85	3	
24	--	129G90-19640	Hose, 3/8" ID, Dosing Module to Degas, 29.5"	1	
25	----	129F88-19460	Helical Spring Lock Washer, M5	2	
27	---	129G88-19440*	Assy, DEF Tank Bracket	1	
28	---	129G88-19460*	Bracket, Base	1	
29	---	129G88-19450*	Bracket, Misc	2	
30	---	129G01-19521*	Supply Module (SM)	1	Included w/ the engine as loose part
31	---	129F01-19800*	Nox Module	2	Assembled to the engine.
32	---	129F01-19590*	Dosing Module (DM)	1	Assembled on the engine.
33	----	26106-080122*	Bolt, M8-1.25X12	1	
34	---	26106-060162*	Bolt, M6X16	4	Assembled on the engine.

MODELS
4TN107FTT-1SYA2

NOTE: 1. Item No. 4, 5, and 6 are corrugated hoses included in the DEF kit.
2. Item No. 7 to 11 are rubber hoses included in the DEF Kit.
3. Service parts are denoted by an asterisk. To replace non-service parts, the entire kit will need to be purchased.

Installation Instructions

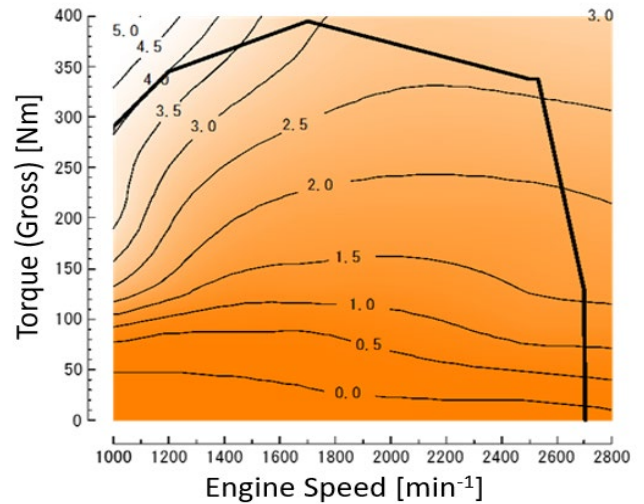
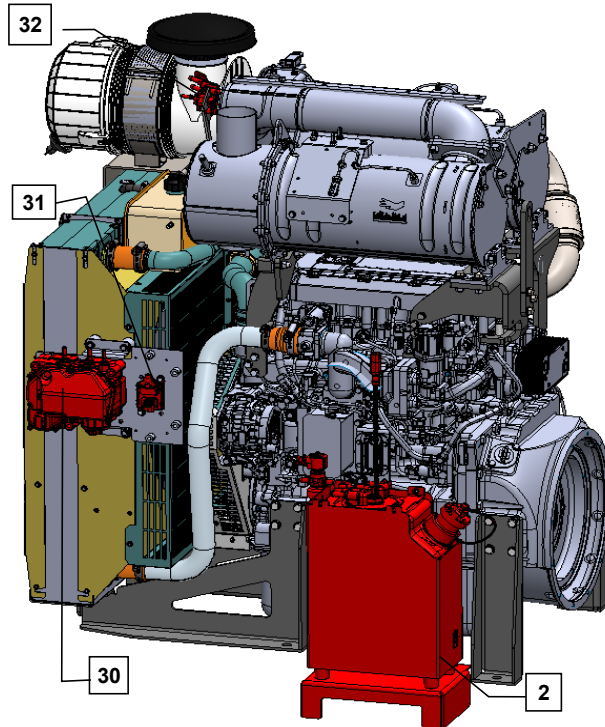

The above image is for illustration purpose only and does not represent the actual DEF consumption.

WARNING: As EPA requirement, for regulation applied area, set the urea water tank capacity so that the urea water replenishment timing to the urea water tank is adjusted such that the refueling of fuel is performed at least once for one urea water supplementation, even in the operating condition with the worst urea water consumption amount.

DEF System Precautions:

- 1- Place the tank where the hot air from the engine or other machine components will not strike it directly and the tank is prevented from over heating.
- 2- Do not cutoff or unplug the wires from the battery until the power of the DCU is turned off as urea water will be returned to the DEF tank over a 10 minute standby time after the engine key is turned off.
- 3- Ensure AdBlue® is used as the urea water in the DEF tank which confirms to ISO22241-1. Do not use any fluid not labeled AdBlue® and also do not add or mix other substances into AdBlue®.
- 4- Ensure DEF system (DEF Tank, Urea Water, DEF Hoses, SM, and DM) are not contaminated with other substances like oil, fuel, etc.
- 5- YMR recommends not to use different hoses other than the Hoses included in the DEF Kit.
- 6- **The highest DEF consumption rate is 3% per gallon of fuel and the current size of the DEF tank (5 gallon) will support fuel tanks upto 166 gallons.**

Table 1: Comply with torque standards in the table to avoid unexpected damage during installation or in the future.

Diameter x Pitch	Kgf-m	Foot-lbf	N-m
5/16" - 18 Nut	~0.86	~6.25	~8.47
M5 X 0.8	0.4 ~ 0.7	3 ~ 5	4 ~ 6.7
M8 X 1.25	1.5 ~ 2.9	10.6 ~ 20.9	14.4 ~ 28.3
M10 X 1.5	4.5 ~ 5.5	32.5 ~ 39.8	44.0 ~ 54.0
Hose Clamps	0.3 ~ 0.4	1.8 ~ 2.5	2.5 ~ 3.4

KDEF Installation Instructions

- 1 Fasten the isolators (4) to bottom of the DEF Tank Bracket (27) that is included in the DEF kit. Attach the Bracket Base (28) using M8 bolts (33). The Bolt, M8-1.25X30 (21) can be used to fasten the DCU to side the DEF Tank Bracket (27).

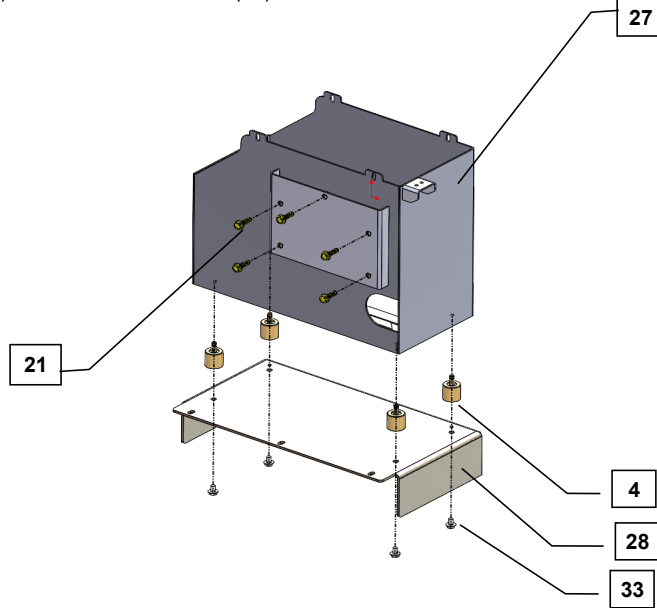

- 2 Place the DEF Tank assembly (2) inside the DEF Tank Bracket (27) as shown in the picture below.

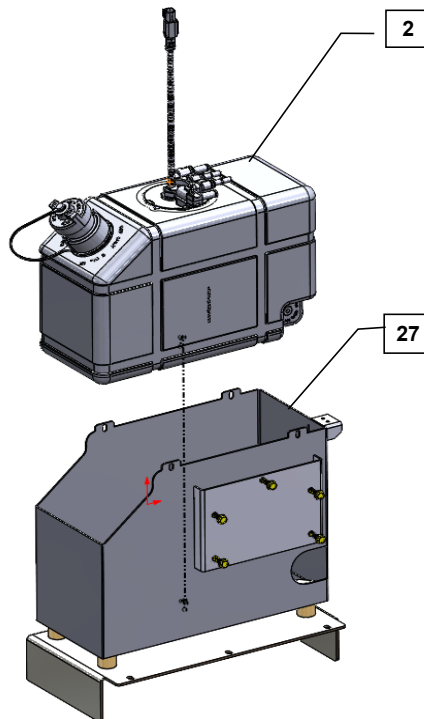

- 3 Fasten the two Brackets (29) on top of each corner of the DEF Tank Bracket (27) using Bolt, M8-1.25X16 (20).

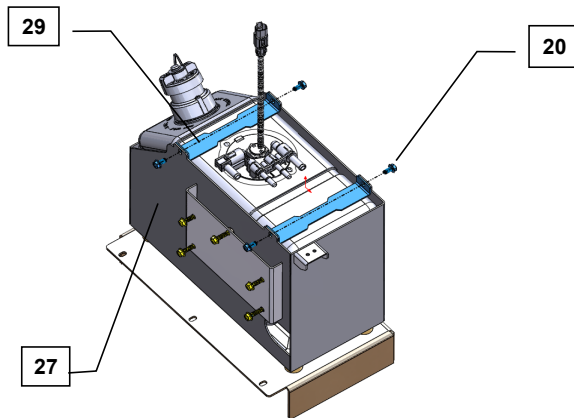

- 4 Install the Coolant control valve (2) to the DEF Tank Bracket (27) as shown in the picture below using Bolt M5-0.8X8 (22) and washer M5 (25).

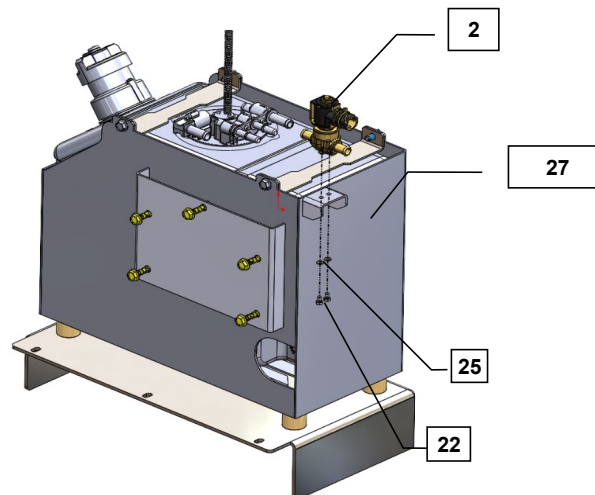

- 5 Assemble the Supply Module (30) to the Supply Module Bracket (16) using Bolt, M8-1.25X85 (23).

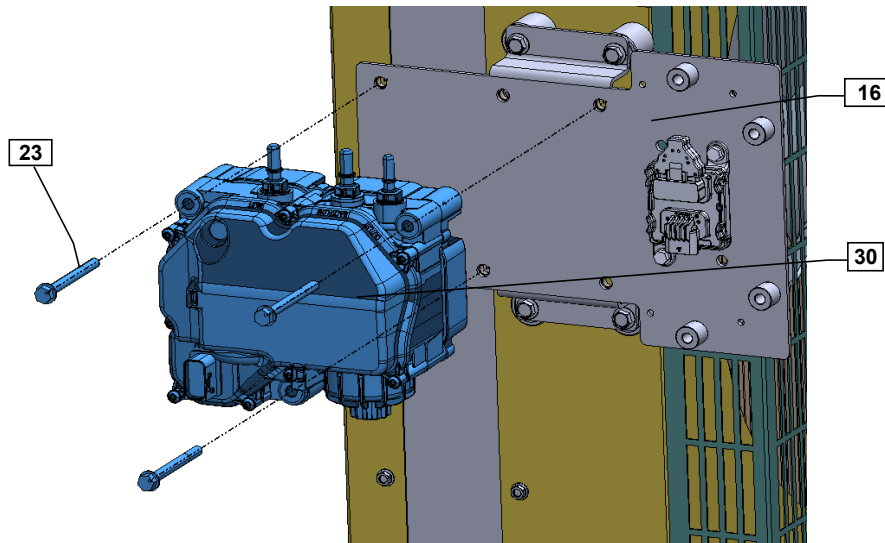

- 6 Nox In & Out Sensors (31) comes assembled with the engine using Bolt, M6X16 (34). Even though it is optional to mount the Nox sensors at the pre-assembled locations, it is highly recommended to relocate the Nox sensors to this plate as they have strict vibration criteria.

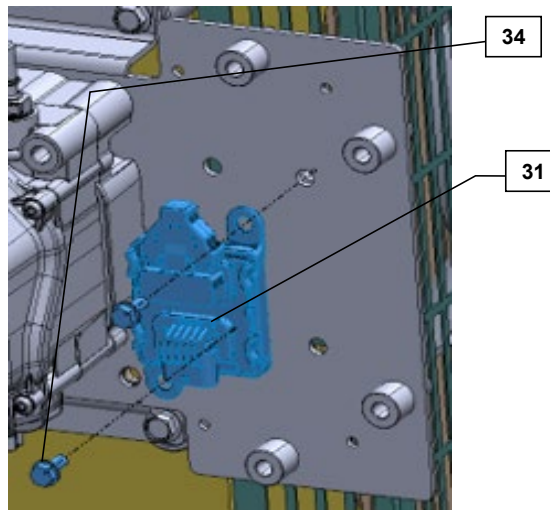

KDEF Installation Instructions

- 7 Attach the Hose, 5/16" ID, Pressure Line (6) to the Supply Module (30) and the Dosing Module (32). A white ring on each Hose (6) connectors is used to lock and unlock the hose connection. Ensure the DEF line makes a positive connection when installing.

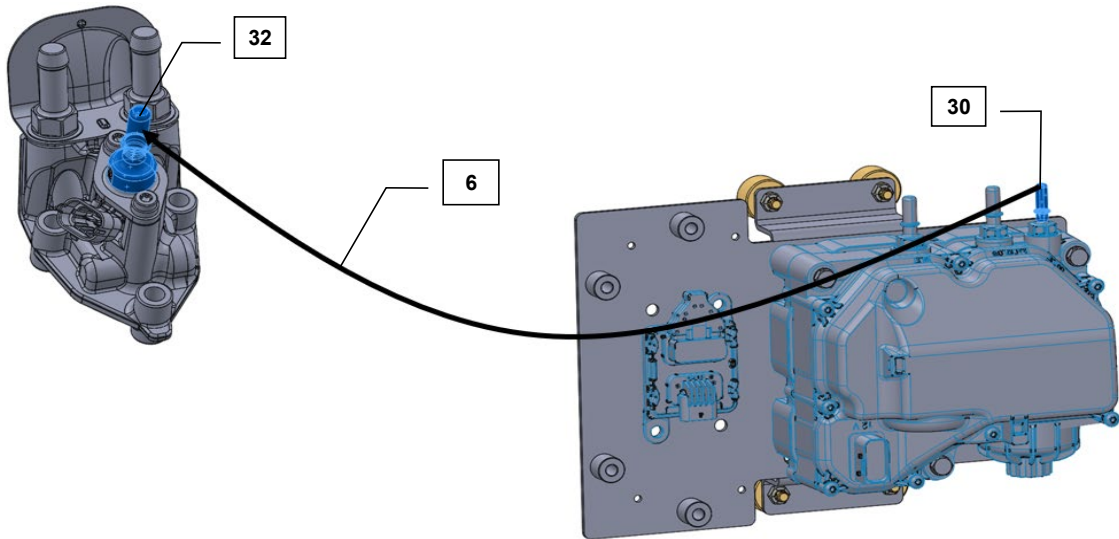

* SM Bracket, and Layout for 4TNV94FHT shown here

- 8 Attach the Hose, 3/8" ID, Return Line (5) to the Supply Module (30) and the DEF Tank (2). A white ring on each Hose (6) connectors is used to lock and unlock the hose connection. Ensure the DEF line makes a positive connection when installing.

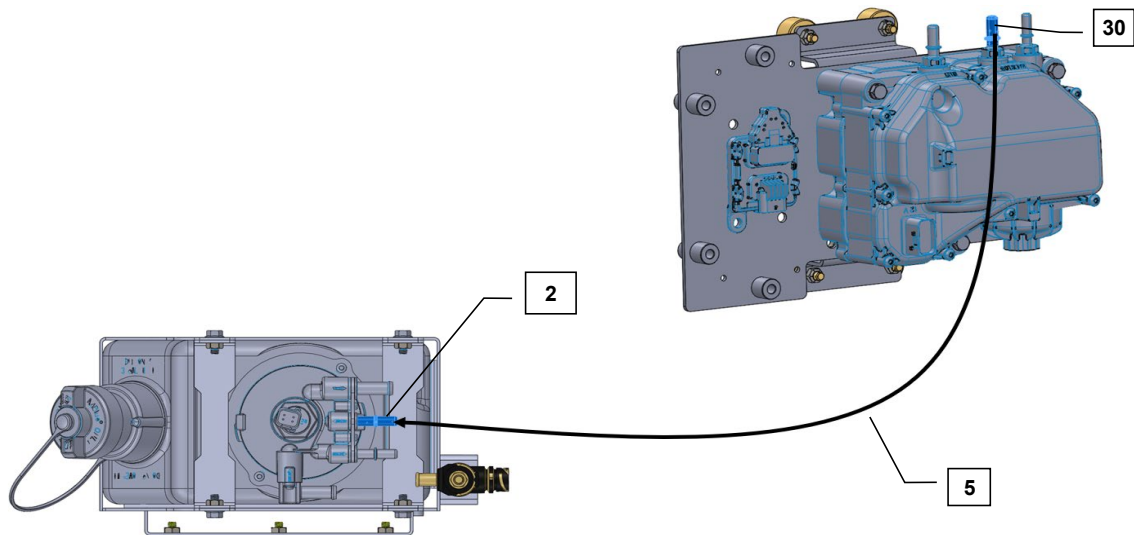

* SM Bracket layout & KDEF1 for 4TNV94FHT shown here

KDEF Installation Instructions

- 9 Attach the Hose, 3/8" ID, Supply Line (4) to the Supply Module (30) and the DEF Tank (2). A white ring on each Hose (6) connectors is used to lock and unlock the hose connection. Ensure the DEF line makes a positive connection when installing.

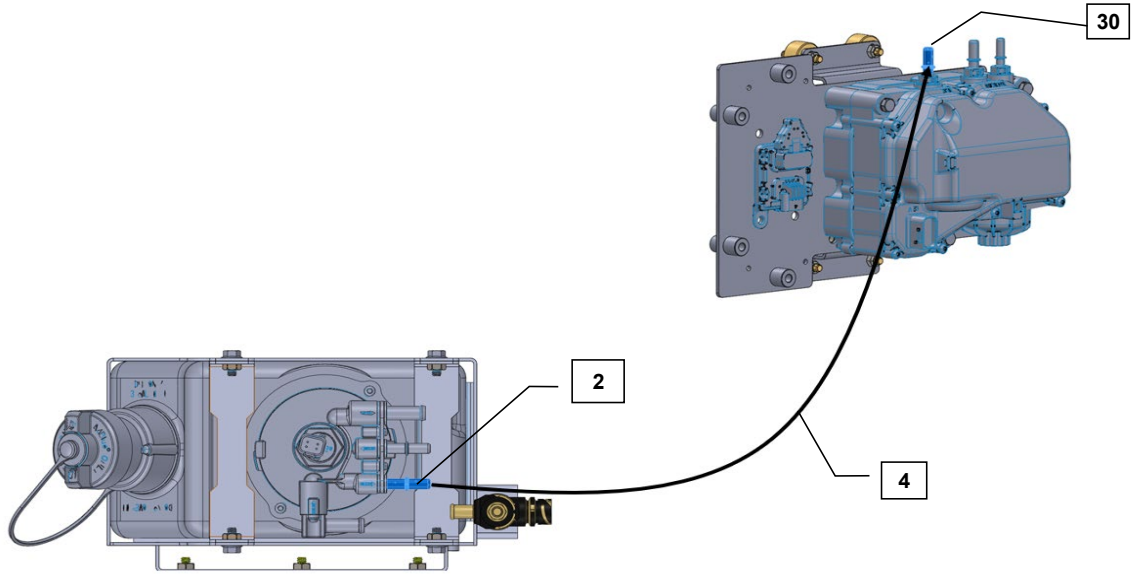

* SM Bracket layout & KDEF1 for 4TNV94FHT shown here

- 10 Cut the Hose, 3/8" ID (7) provided in the DEF kit to precise length **400 mm**, and attach it to the Engine block and Tee Fitting (15) using Hose Clamps (12). Ensure the coolant line is well connected to prevent leaks.

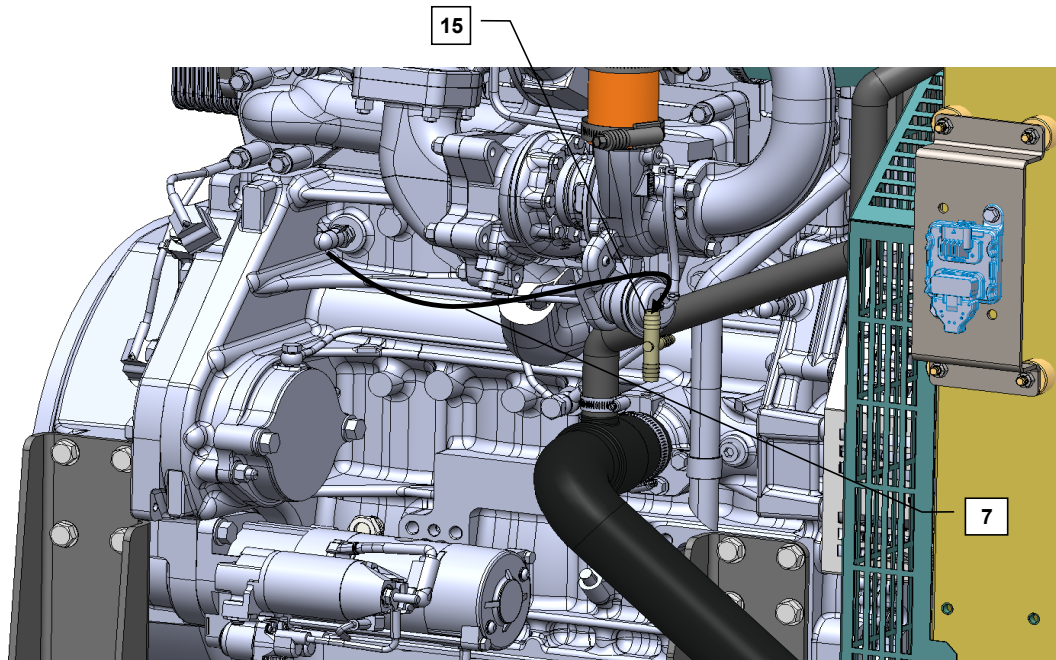

KDEF Installation Instructions

- 11 Cut the Hose, 3/8" ID (8) provided in the DEF kit to precise length **1300 mm**, and attach it to the Tee Fitting (15) and the Dosing Module (32) using Hose Clamps (12). Ensure the coolant line is well connected to prevent leaks.

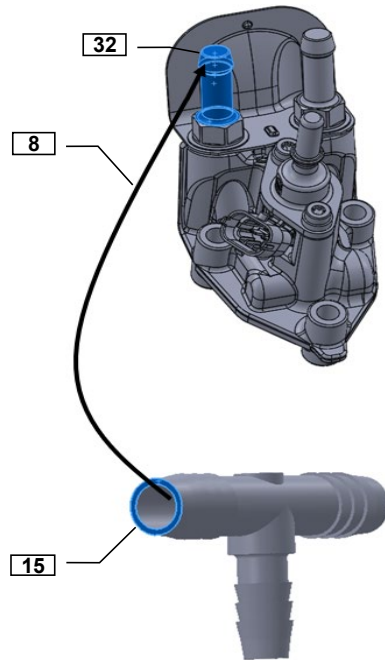

* KDEF1 for 4TNV94FHT shown here

- 12 Cut the Hose, 1/2" ID (10) provided in the DEF kit to precise length **1742 mm**, and attach it to the Tee Fitting (15) and the Coolant Control Valve (3) using Hose Clamps (12). Ensure the coolant line is well connected to prevent leaks.

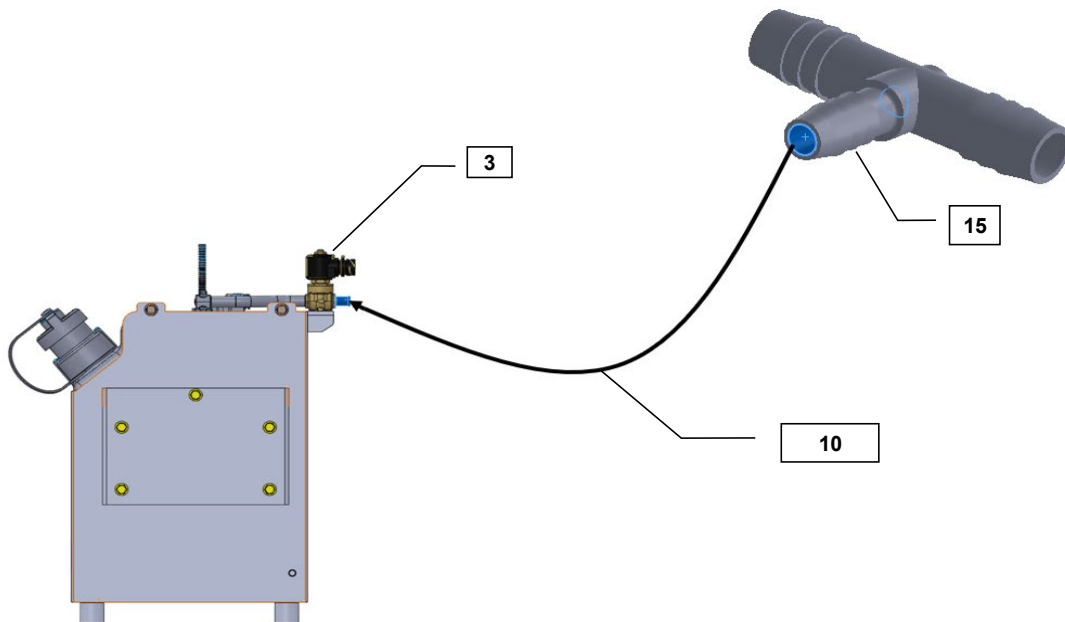

* KDEF1 for 4TNV94FHT shown here

KDEF Installation Instructions

- 13 Cut the Hose, 1/2" ID (9) provided in the DEF kit to precise length **1800 mm**, and attach it to the DEF Tank (2) and the Engine water pump inlet using Hose Clamps (12). Ensure the coolant line is well connected to prevent leaks.

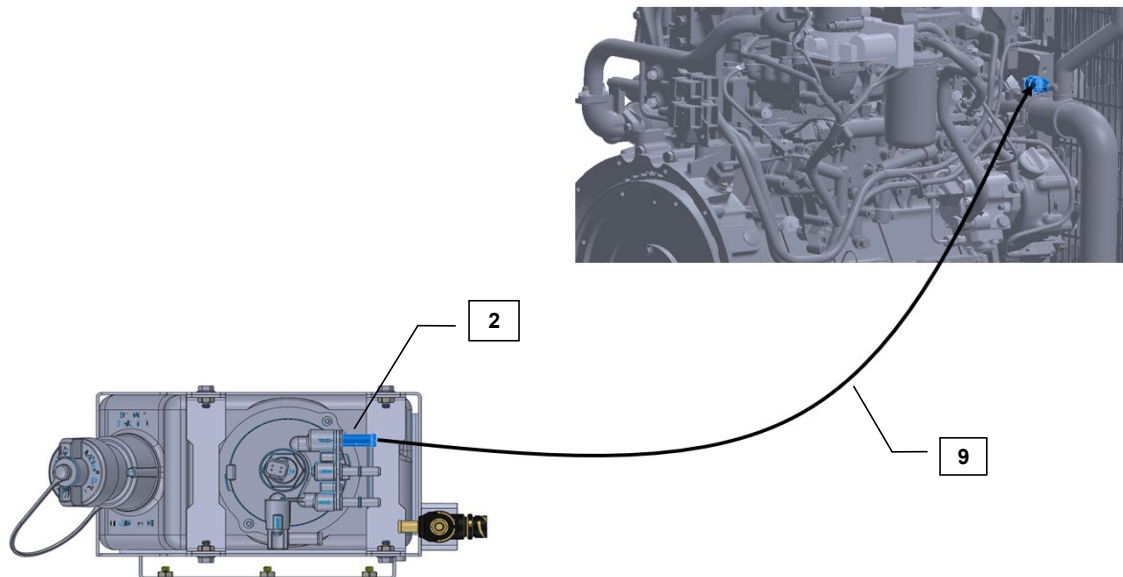

* KDEF1 for 4TNV94FHT shown here

- 14 Cut the Hose, 1/2" ID (11) provided in the DEF kit to precise length **230 mm**, and attach it to the DEF Tank (2) and the Coolant Control Valve (3) using Hose Clamps (12). Ensure the coolant line is well connected to prevent leaks.

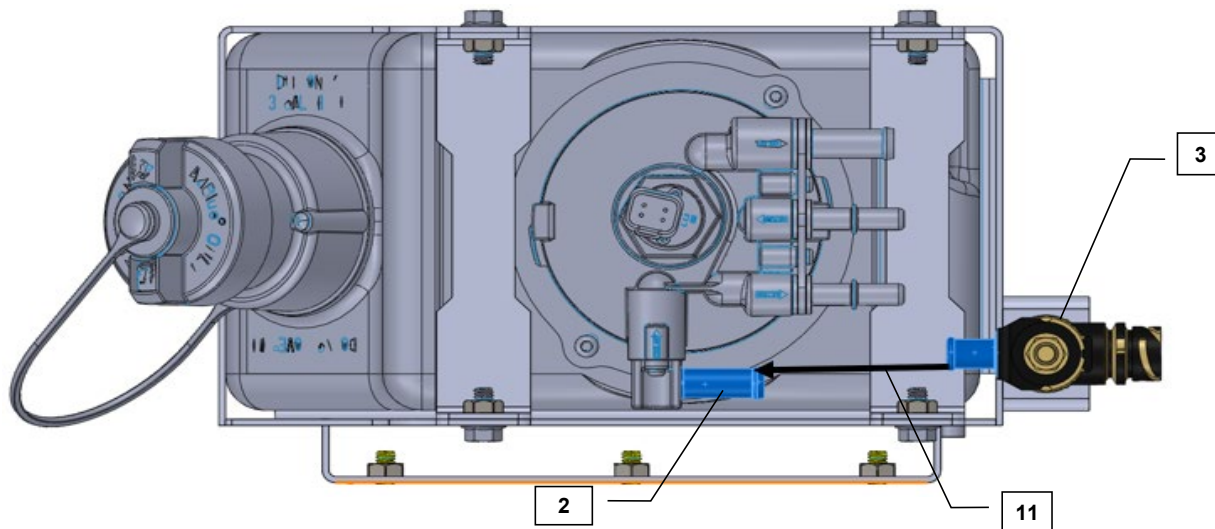

* KDEF1 for 4TNV94FHT shown here

KDEF Installation Instructions

- 15 Cut the Hose, 3/8" ID (24) provided in the DEF kit to precise length **750 mm**, and attach it to the Dosing Module and the Radiator Degas Tank using Hose Clamps (12). Ensure the coolant line is well connected to prevent leaks.

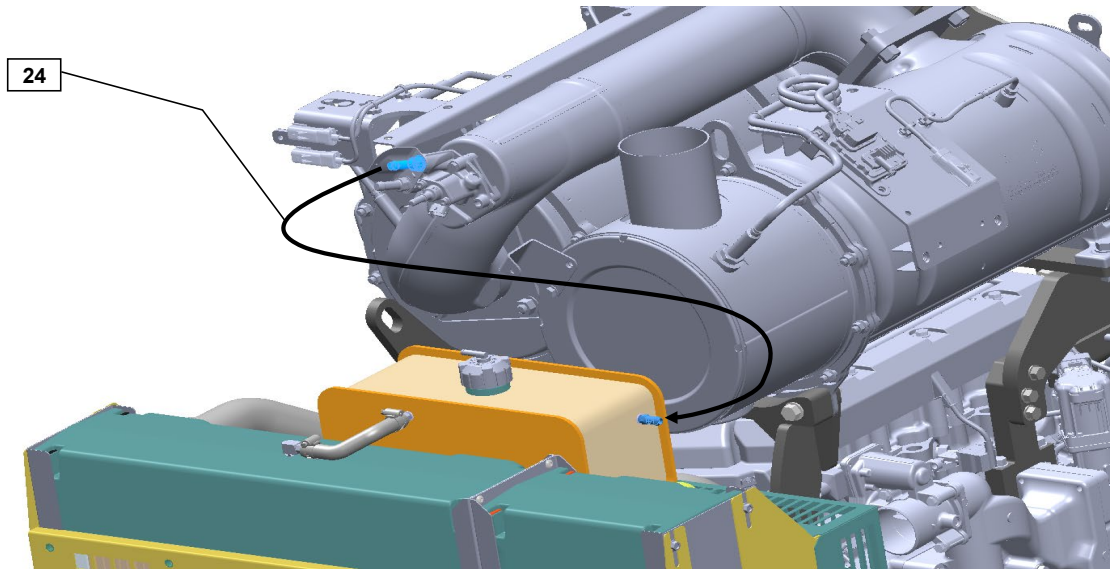

Note: Attach Degas Hose to highlighted fittings.

