



Supplement to Yanmar Kit Installation Instructions

SAFETY

This product is designed and intended only for use with a YANMAR engine. All safety and warning information contained in the Yanmar Operation Manual and Service Manual is adopted and incorporated to apply to the components, accessories, and parts that are utilized with Yanmar engines. Follow all instructions and precautions before installing this product, before operating, during operation, and during periodic maintenance procedures for your safety, the safety of others, and to protect the performance of your engine.



Item	Part No.	Description	Quantity	Remarks
1	129F88-42850	Belt Guard	1	
2	129F88-42860	Belt Guard	1	
3	129F88-42870	Belt Guard	1	
4	119E34-44900	Bolt, M10 x 0.5 - 16	8	

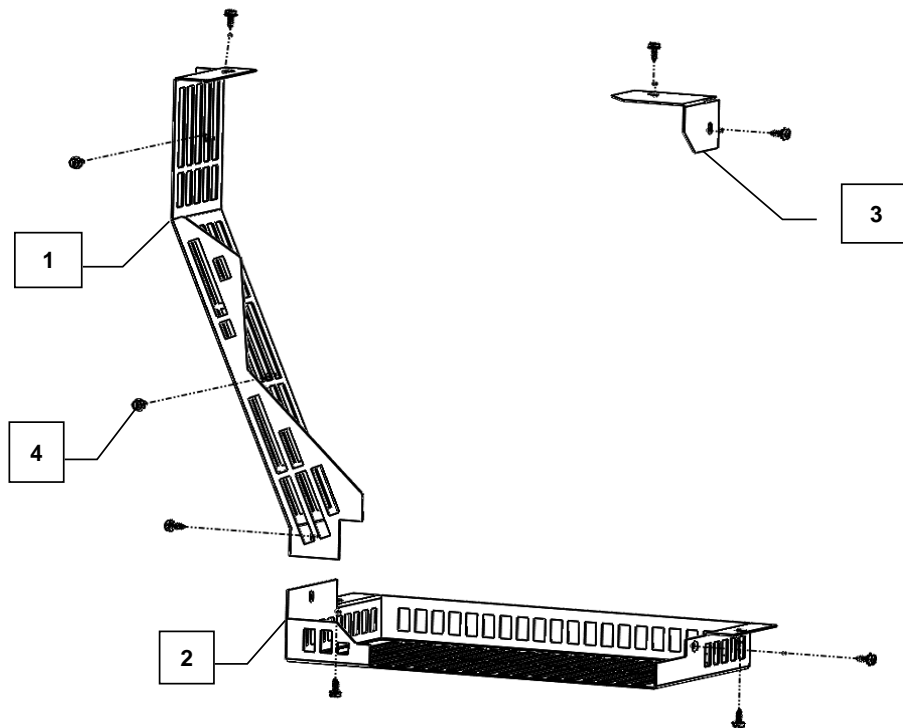

MODELS
4TNV94FHT-NYEA2

Note: Service parts are denoted by an asterisk. To replace non-service parts, the entire kit will need to be purchased.



Installation Instructions

Hand tighten all bolts and nuts until assembly is completed, then torque according to specifications in Table 1. The numbers in () represent the item numbers.

1. Assemble Belt Guard (1) for the alternator belt side and fasten to the radiator fan guard using M10 X 0.5 - 16 (4).
2. Assemble Belt Guard (2) to the bottom of the crankshaft pulley and fasten to the radiator fan guard using M10 X 0.5 - 16 (4).
3. Mount Belt Guard (3) for water pump pulley and fasten to the radiator fan guard using M10 X 0,5 - 16 (4).

NOTE: Comply with torque standards in the table to avoid unexpected damage during installation or in the future.

TABLE 1: Tightening Torque

Diameter x Pitch	Kgf-m	Foot-lbf	N-m
M10 x 0.50	4.5 ~ 5.5	32.5 ~ 39.8	6.5 ~ 8.5