



## Supplement to Yanmar Kit Installation Instructions

# SAFETY

---

This product is designed and intended only for use with a YANMAR engine. All safety and warning information contained in the Yanmar Operation Manual and Service Manual is adopted and incorporated to apply to the components, accessories, and parts that are utilized with Yanmar engines. Follow all instructions and precautions before installing this product, before operating, during operation, and during periodic maintenance procedures for your safety, the safety of others, and to protect the performance of your engine.

Kit Name: KHOP1



Item	Part No.	Description	Quantity	Remarks
1	129484-26200*	HOP Drive (Complete)	1	9T, 16/32 DP
2	171353-26081*	Gasket	1	
3	24321-000850*	O-Ring	1	
4	26450-080282*	Screw, M8x1.25-28, (Cap, Hex Socket Head)	1	

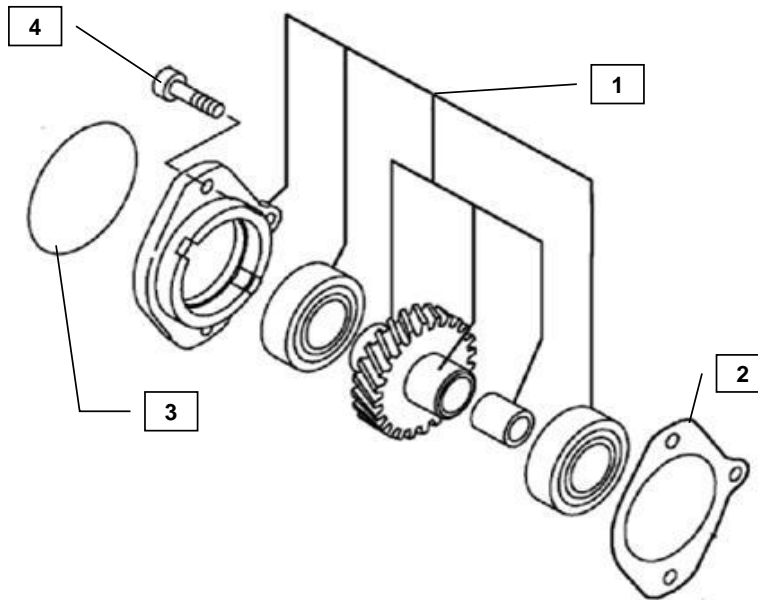

**MODELS**

3TNV82A  
3TNV88  
3TNV84T  
4TNV88  
4TNV84T

Note: Service parts are denoted by an asterisk. To replace non-service parts, the entire kit will need to be purchased.



### Installation Instructions

1. Remove the cover and the O-ring. Do not reuse the O-ring.
2. Put the gasket (2) on the HOP gear drive (1) and insert them from the back of gear case.
3. Tighten the socket screw (4) per tightening torque table.
4. Put the O-ring (3) before a hydraulic pump.

NOTE: Comply with torque standards in the table to avoid unexpected damage during installation or in the future.

**Table 1: Standard Nut and Bolt Tightening Torque**

Diameter x Pitch	Kgf-m	Foot-lbf	N-m
M8 x 1.25	1.5 ~ 2.9	10.6 ~ 20.9	14.4 ~ 28.3
M10 x 1.50	4.5 ~ 5.5	32.5 ~ 39.8	44.0 ~ 54.0
M12 x 1.75	8.0 ~ 10.0	57.8 ~ 72.3	78.4 ~ 98.0