



Supplement to Yanmar Kit Installation Instructions

## SAFETY

---

This product is designed and intended only for use with a YANMAR engine. All safety and warning information contained in the Yanmar Operation Manual and Service Manual is adopted and incorporated to apply to the components, accessories, and parts that are utilized with Yanmar engines. Follow all instructions and precautions before installing this product, before operating, during operation, and during periodic maintenance procedures for your safety, the safety of others, and to protect the performance of your engine.

Kit Name: KAC25



Item	Lev.	O	Part No.	Description	Quantity	Remarks
1 to 12	-		KAC25	Air Cleaner Kit	1	
1	--		129087-12500*	Air Cleaner Assy	1	
2	---		129087-12510*	Air Cleaner Element	1	
3	--		129087-12570*	Band, Air Cleaner	1	
4	--		119E34-12310*	Bracket	1	
5	--		119E34-12700*	Hose	1	
6	--		119E34-12830*	Bolt, M6 X 1.25 - 30	2	
7	--		119E34-12840*	Bolt, M8 X 1.25 - 65	1	
8	--		26106-080162*	Bolt, M8 X 1.25 - 16	3	
9	--		26106-080202*	Bolt, M8 X 1.25 - 20	2	
10	--		26366-080002*	Nut, M8	2	
11	--		23000-054000*	Clamp 54, Hose	1	
12	--		23000-060000*	Clamp 60, Hose	1	
13	--		129087-12600*	Rain Cap	1	
14	--		129927-91200	ATM Sensor (Included with the Engine loose box)	1	

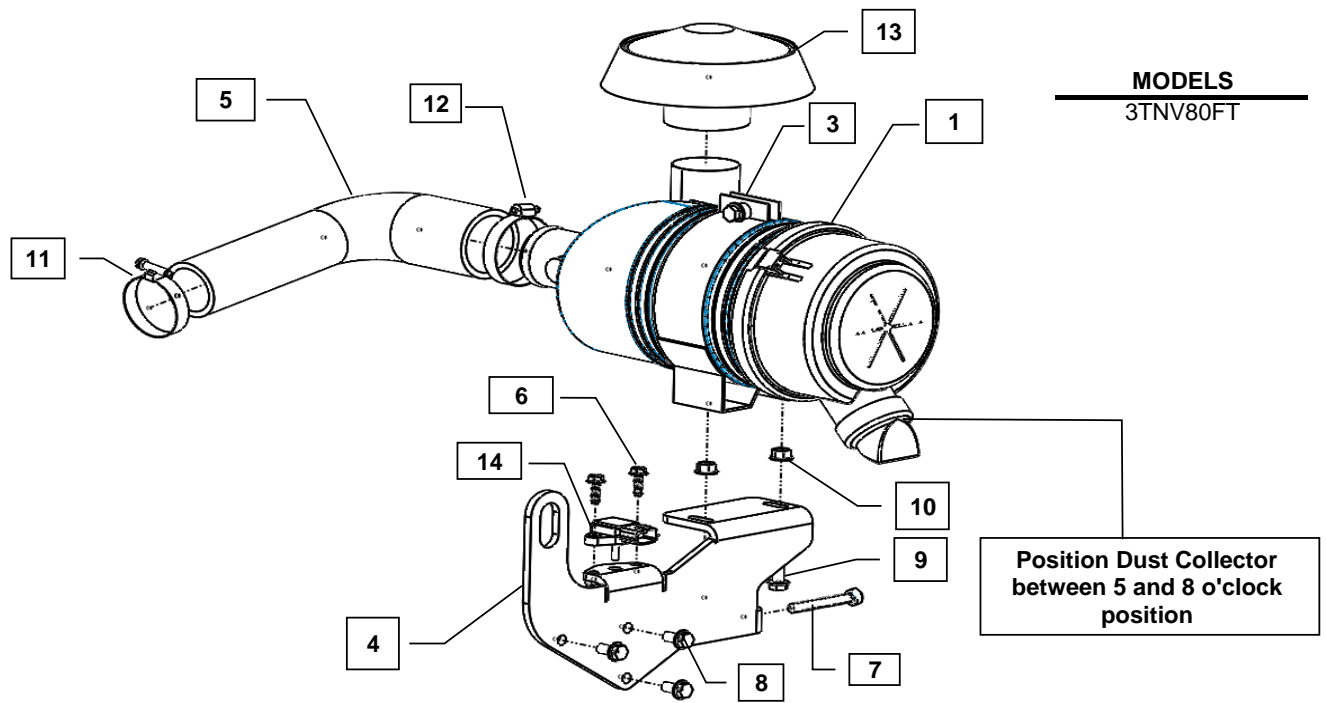

Note: Service parts are denoted by an asterisk. To replace non-service parts, the entire kit will need to be purchased.

Remarks: Kit includes Donaldson part number label.



## Installation Instructions

Hand tighten all bolts and nuts until assembly is completed, then torque according to specifications in Table 1. The numbers in () represent the item numbers.

1. Fasten the Air Cleaner Band (3) on to the Air Cleaner Bracket (4) using M8 x 1.25 - 20 bolts (9) and M8 Flange Nuts (10).
2. Assemble Air Cleaner Band (3) and Bracket (4) assembly to the rear side of the engine block with M8 x 1.25 - 16 bolts (8) and M6 x 1.25 - 30 bolts (6).
3. Fasten one end of the Air Cleaner Bracket (4) to the fuel filter on the engine side using M8 x 1.25 - 65 bolt (7).
4. Open the Air Cleaner Band (3) by removing the bolt and spring fastener from the assembly. Remove the Air Cleaner Cover and Element (2) from the Air Cleaner (1). This will allow the Air Cleaner (1) to slide into the Air Cleaner Band (3).
5. Insert the Air Cleaner (1) in the Band (3) and position in the recess provided on the Air Cleaner. Fasten it with the bolt and spring that came with the Band. Reinstall the Air Cleaner Cover and adjust the orientation so the dust collector is positioned downward, between the 5 and the 8 o'clock position.
6. Fasten one end of the Air Cleaner Hose (5) to the Turbo inlet using Band Clamp (11). Fasten other end of the hose to the Air Cleaner (1) using the other Band Clamp (12).
7. Fasten the Rain Cap (13) to the inlet of Air Cleaner (1) using the clamp that comes with the Rain Cap.
8. Install the included Air Cleaner Label on the Air Cleaner (1) or a piece of equipment in the area of the Air Cleaner. Be sure Label is visible and is not placed on the Cleaner Cover.
9. Fasten the ATM sensor (14) on the Air Cleaner Bracket (4) using M6 x 1.25 - 30 bolts (6).

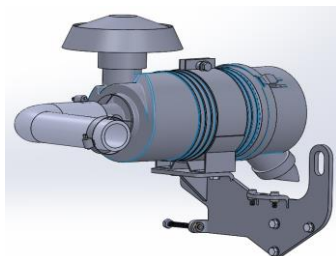

NOTE: Comply with torque standards in the table to avoid unexpected damage during installation or in the future.

**Table 1: Tightening Torque**

Diameter x Pitch	Kgf-m	Foot-lbf	N-m
M8 x 1.25	1.5 ~ 2.9	10.6 ~ 20.9	14.4 ~ 28.3
M6 x 1.25	1.0 ~ 1.2	7.2 ~ 8.6	9.8 ~ 11.8
Hose Clamps	0.25 ~ 0.35	1.84 ~ 2.51	2.5 ~ 3.4