



Supplement to Yanmar Kit Installation Instructions

SAFETY

This product is designed and intended only for use with a YANMAR engine. All safety and warning information contained in the Yanmar Operation Manual and Service Manual is adopted and incorporated to apply to the components, accessories, and parts that are utilized with Yanmar engines. Follow all instructions and precautions before installing this product, before operating, during operation, and during periodic maintenance procedures for your safety, the safety of others, and to protect the performance of your engine.



Item	Lev.	O	Part No.	Description	Quantity	Remarks
1	--		129F88-12500*	Air Cleaner Assembly	1	
2	--		129F88-12040*	Band, Air Cleaner	1	
3	--		129F88-12050*	Rain Cap, Air Cleaner	1	
4	---		129F88-12710	Clamp, Rian Clamp	1	
5	---		129F88-12700*	Upper Mount, Bracket	1	
6	--		129F88-12600*	Bracket, Misc	1	
7	--		129F88-12200*	Hose, Air Intake	1	
8	--		26106-080202*	Bolt, M8 X 1.25 - 20	2	
9	--		26106-080302*	Bolt, M8 X 1.25 - 30	5	
10	--		129F88-12010*	Clamp, Hose, 52-76 OD	1	
11	--		129F88-12020*	Clamp, Hose, 48-127 OD	1	
12	--		129F88-12030*	Clamp, Hose, 33-57 OD	1	

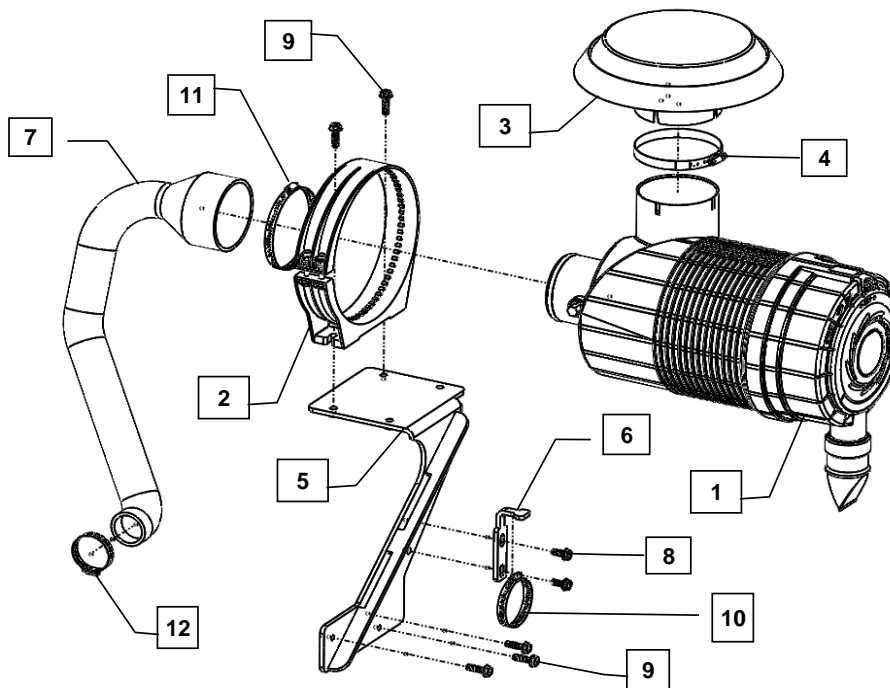

MODELS
4TNV94FHT-NYEA2

Note: Service parts are denoted by an asterisk. To replace non-service parts, the entire kit will need to be purchased.

Remarks: Kit includes Donaldson part number label.



Installation Instructions

Hand tighten all bolts and nuts until assembly is completed, then torque according to specifications in Table 1. The numbers in () represent the item numbers.

1. Fasten the Air Cleaner Band (2) onto the Upper Mount Bracket (5) using M8x1.25-30 bolts (9).
2. Assemble Air Cleaner Band (2) and Upper Mount Bracket (5) assembly to the Aftertreatment bracket which is below SCR exhaust outlet with M8x1.25-30 bolts (9). Refer below picture for mounting holes on the Aftertreatment bracket.
3. Fasten the Bracket (6) to the Upper Mount Bracket (5) using M8x1.25-20 bolts (8). Include the Clamp (10) around the bracket (6) to fasten with the CAC top hose.
4. Open the Air Cleaner Band (2) by removing the bolt and spring fastener from the assembly. Remove the Air Cleaner Cover and Element from the Air Cleaner (1). This will allow the Air Cleaner (1) to slide into the Air Cleaner Band (2).
5. Insert the Air Cleaner (1) in the Band (2) and position in the recess provided on the Air Cleaner. Fasten it with the bolt, spring, and nut that came with the Band. Reinstall the Air Cleaner Cover and adjust the orientation so the dust collector is positioned exactly downward.
6. Fasten the small diameter of the Air Cleaner Hose (7) to the turbo inlet using Hose Clamp (12). Fasten the large diameter end of the Hose to the Air Cleaner (1) using Hose Clamp (11).
7. Install the Hose Clamp (10) around the Bracket (6) and fasten around the upper CAC piping.
8. Fasten the Rain Cap (3) to the inlet of Air Cleaner (1) using the clamp that comes with the Rain Cap (4).
9. Install the Air Cleaner Label on the Air Cleaner (1) or a piece of equipment in the area of the Air Cleaner. Be sure Label is visible and is not placed on the Air Cleaner Cover.

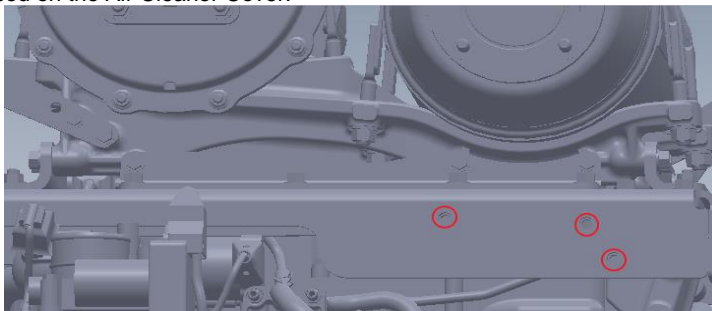

NOTE: Comply with torque standards in the table to avoid unexpected damage during installation or in the future.

Table 1: Tightening Torque

Diameter x Pitch	Kgf-m	Foot-lbf	N-m
M8 x 1.25	1.5 ~ 2.9	10.6 ~ 20.9	14.4 ~ 28.3
Hose Clamps	0.25 ~ 0.35	1.84 ~ 2.51	2.5 ~ 3.4