



YANMAR

B110W

COMPACT WHEELED EXCAVATOR



Operating weight	11 000 - 12 500 kg
Digging depth	4,3 - 4,6 m
Engine power	85 kW (116 HP)
Bucket capacity	149 – 477 l
Digging force (arm)	58,5 kN
Digging force (bucket)	72 kN
Reach	8.3 – 8.65 m

B110W

POWERFULL IN USE





HIGH PERFORMANCE

The B110W is very efficient and can perform tasks reserved for machines with higher weight. Thanks to its enormous lifting capacities and its precise hydraulic system, this 11 tons is capable of transporting and positioning particularly heavy loads on construction sites.

This machine has great advantages for the logistics of materials and is therefore very interesting in construction and especially for the road construction.

Equipped with a grab bucket, it allows in horticulture to catch and to load trunks.



ENGINE

Due to the latest EU Stage V / TIER 4 final Final engine generation, the B110W works economically and is environmentally friendly. The B110W is also equipped with an Eco Mode.



SMART CONTROL

Smart Control System increases efficiency, the driver determines the optimum excavator power for different applications. This minimizes losses of energy or time.



EASY MAINTENANCE

The main organs of the machine are accessible very quickly and safely. The wide opening of the covers enables fast daily checks.



COMFORTABLE CABIN

The ergonomically-designed cab provides the operator with an exceptionally comfortable environment that enables a high degree of productivity. From the neatly arranged, clearly structured displays through the generously dimensioned storage compartments to the

Soft-Touch interior or the optional Klimatronik – one thing is clear: the workplace is designed for the operator.



EASY TO USE

The B110W is fitted with various equipment which enable precise, comfortable and productive control of the machine: Smart control, Fingertip control and multi-function joysticks offer optimal handling to the operator for a productive workday.



RELIABILITY OF POWERLINE

The components of the powerline are highly efficient and reliable: no need to choose between power and compactness. Yanmar customers can make heavy tasks of construction site in narrow spaces.

POWER AND EFFICIENCY



IMPROVED POWERLINE

THE ENGINE

The B110W is driven by a EU Stage V / TIER 4 final Final engine. Exhaust gas after-treatment reduces emissions by up to 90%, including nitrogen oxides (NOx), hydrocarbons (HC) and fine dust. This is achieved through an improved combustion and injection system, a diesel oxidation catalyst (DOC) and a selective catalytic reduction (SCR). The engine does not need a particulate filter to fulfill the Euro IV requirements.

THE REVERSIBLE FAN

The hydraulically-driven reversible fan is temperature controlled. The cooling capacity automatically adjusts to the cooling requirement. The fan only runs when necessary. This saves fuel and conserves the material. The driver can switch the fan

manually if required. The cleaning by reversal takes place either automatically or manually.

THE AUTOMATIC IDLING

The auto idling function (optional) saves fuel. If there is no activity, the engine switches to the idling position – hence reducing the fuel consumption.

AUTOMATIC ENGINE SHUTDOWN

The switch-off time can be freely selected by the driver (optional) this will be activated by the ECO switch.

FURTHER ADVANTAGES

- + Articulated joint with wide angle of articulation allows for working closely along walls.



HYDRAULICS SYSTEM WITH FOUR INDEPENDENT CIRCUITS

Thanks to the four independent hydraulic circuits, the B110W wheel excavator increases its capacity with attachment tools. The driver can operate a tilt rotator with a hydraulic quick-hitch system and a hydraulically-driven tool, such as a sorting grab, asphalt cutter or cutting unit, for example. The control circuits can be operated at the same time, they do not influence each other. All cylinders have end position damping for low-vibration working.

PERFORMANCE



SPEED

A quick change of construction site or location is possible with speeds of up to 36 km/h. Non-productive transport times are reduced to a minimum.

STABILITY

Its class leading stability is exceptional for a machine in that size

class and can even be improved by the choice of optional tires or additional counterweight.

FURTHER ADVANTAGES

- + Hydrostatic travel drive, independent of the working hydraulics – also functions as an additional brake system
- + Automatic drive, additional accelerator pedal for delicate machine movements.

UNDERCARRIAGE

The undercarriage combines high terrain mobility with drive power. It can be configured as exactly as required due to a wide range of equipment variants.

PENDULUM AXLE

Due to the pendulum axle with a pendulum angle of 13°, the wheeled excavator is absolutely stable even on uneven ground.

STEERING

Equipped with two-wheels steering. Four-wheel steering is optional available.

LEVELING

The optional float function of the dozer blade makes leveling of the ground, the filling processes or cleaning of the construction site easier.

EASE OF USE



SMART CONTROL

Smart Control is an operating system for compact wheel excavators that makes controllability more easy and comfortable. What this means for you:

- + Intuitive operation that is easy to set for each individual driver
- + The flow of hydraulic auxiliary circuits can easily be adjusted
- + Display design to enable easy machine monitoring
- + Keypad with extra-large keys for easy operation



PRECISE FINGERTIP CONTROL

The fingertip control allows the operator to regulate the oil flow with real precision, all the way from «zero» to «full».

The electrical proportional activation of hydraulic functions is simple thanks to a thumbwheel on the joystick. A lot of attention has been paid to an outstanding ergonomomy to improve operator comfort.

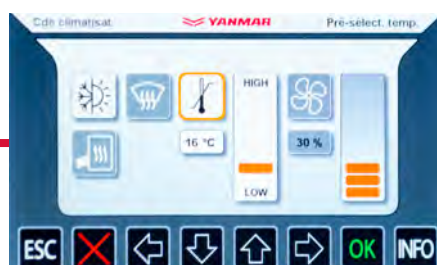



EXEMPLARY MACHINE CONTROL

HYDRAULIC CONTROL CIRCUITS

Allows fast operation. The flow rate of each auxiliary circuit is also adjusted proportionally during continuous operation via a bar chart according to use and attachment tool. The flow setting is stored and stays same even after restarting the engine.

AIR CONDITIONING CONTROL

Heating and defrosting can be adjusted exactly to the required conditions, automatic air conditioning is optional.



OPERATOR STATION



Designed with driver comfort and productivity in mind, the cabs feature noise and vibration damping and are ROPS/FOPS- approved.



DISPLAY AND INSTRUMENTS

For a clearer overview and greater convenience – work functions and machine information can be examined at a central position at a glance. The data display appears in a tiled look like a smart phone. The anti-reflective screen with a 7" diagonal is very clearly arranged and is also used as a monitor for the standard reversing camera.

THE KEYPAD

Extra-wide pressure surface make safe operation easy, even when wearing gloves. The optional immobilizer can be operated.

FURTHER ADVANTAGES

+ Optional heated mirrors are available.

MAINTENANCE

EASY ACCESS

A servicebar with the central electrics is integrated in the service compartment: Hence, all relays and fuses are easy to access from the ground. The flap can be opened without tools. For easier ascent, the ladder in the service flap is extended towards the ground. The flap is provided with rubber buffers, it lies gently on the extended ladder, the materials is conserved. There are no main hydraulic components mounted under the cab. Tilting of the cab is not required – but possible if necessary.



DIAGNOSTIC PLUG

The diagnostic plug for engine and machine data speeds up maintenance and service through better communication between man and machine. «Can bus» data are shown on the display.



Battery main switch

Refueling with a jerry can

TAILORED FOR YOUR JOB



TRAILER COUPLING

As an option, the B110W can be equipped with a trailer coupling with a socket on the undercarriage with a permissible tensile load of 4,800 kilograms for easy transportation.

In this way, required attachments or filling materials such as gravel, crushed stone or sand can be directly loaded onto a trailer and transported with the excavator. An additional truck is not required. This means: greater flexibility, lower costs and less environmental impact. The placement of the socket on the undercarriage ensures that the excavator can also swivel with inserted cables. The coupling is attached to the support plate with a folding mechanism. If necessary, it is simply folded away.

BOOM OPTIONS

The TPA boom is suitable for high-performance digging work, transport and precise positioning of heavy loads – the action radius is designed for the greatest possible working range.

TPA boom, with standard dipperstick 2 000 mm
 TPA boom, with dipperstick 2 350 mm



UNDERCARRIAGE OPTIONS

- + Stabilizers
- + Support plate
- + Front dozer blade
- + 4 wheel steering

TIRES OPTIONS

Low-pressure tires and twin or wide tires are available.



THE ATTACHMENT TOOLS

Excellent versatility thanks to numerous options and attachment tools. Tested and proven in use:

- + Standard bucket
- + Ditch-cleaning bucket
- + Swing bucket
- + Hydraulic cutting units
- + Ripper tooth
- + Lifting hook
- + Screw-on lifting hook
- + Mechanical quick-hitch system
- + Hydraulic quick-hitch system
- + Pallet forks

DIMENSIONS

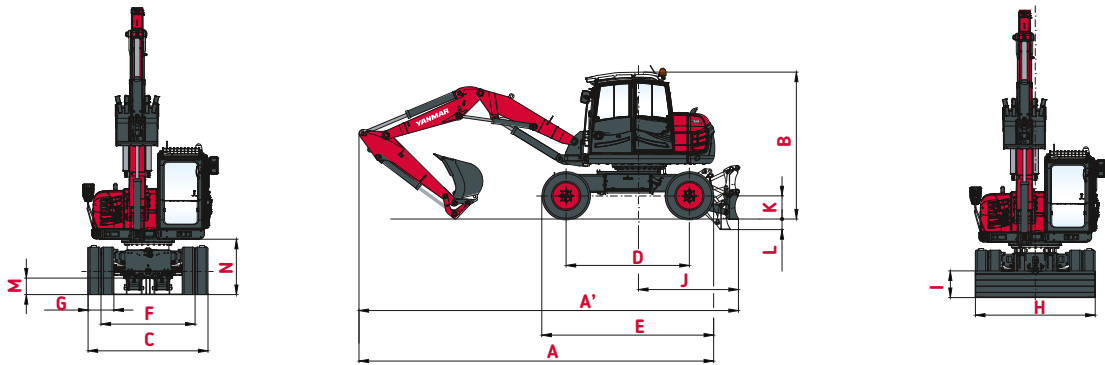

A Overall length	7 390 mm	H Overall blade width	2 500 mm
A' Overall length with blade at the back	7 900 mm	I Overall blade height	555 mm
B Overall height	2 990 mm	J Blade distance	2 085 mm
C Overall width (twin tires)	2 500 mm	K Max. blade height above the ground	485 mm
D Wheelbase	2 570 mm	L Max. blade depth	220 mm
E Length over tires (twin tires)	3 580 mm	M Minimum ground clearance	340 mm
F Lane	1 942 mm	N Ground clearance under counterweight	1 150 mm
G Tire width	540 mm		

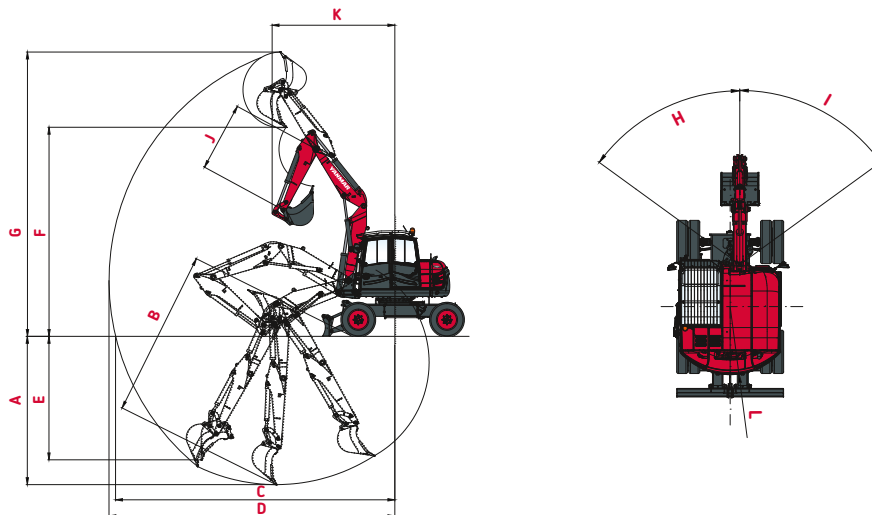

A Max. digging depth - Blade lifted	4 300 / *4 650 mm	G Max. cutting height	8 240 / *8 540 mm
B Max. digging depth - Blade lowered	4 440 / *4 810 mm	H Boom swinging base to left	54°
C Max. digging reach on ground	8 090 / *8 460 mm	I Boom swinging base to right	54°
D Max. digging reach	8 280 / *8 640 mm	J Arm length	2 000 / *2 350 mm
E Max. vertical wall	3 580 / *3 900 mm	K Front turning radius	3 550 / *3 720 mm
F Max. dumping height	6 060 / *6 350 mm	L Rear turning radius	1 600 mm

*TPA Boom with dipperstick 2 350 mm

DIMENSIONS

Fig. 1:
Excavation within the entire width of the machine

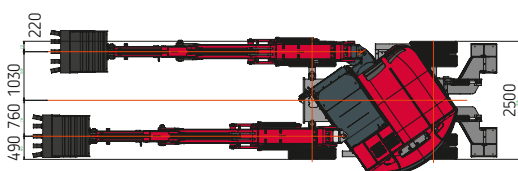

Fig. 2:
Working envelope

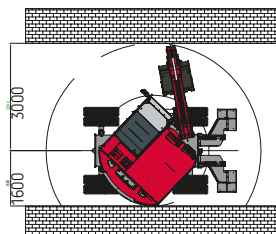
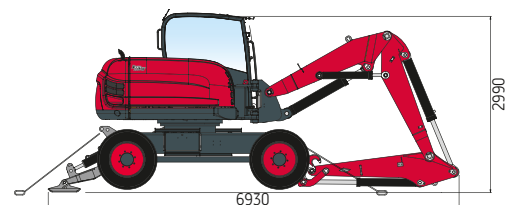

Fig. 3:
Transport position



LIFTING CAPACITIES



Blade down



Blade up

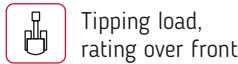

Tipping load, rating over front

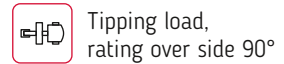

Tipping load, rating over side 90°

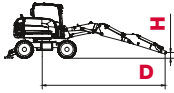

TPA BOOM with dipperstick 2 000 mm

		D									
		3 m		4 m		5 m		6 m		7 m	
H		👤	👤	👤	👤	👤	👤	👤	👤	👤	👤
		3,0 m	👤	--	--	2,59	2,43	2,16	2,00	2,10	1,26
👤	--		--	2,62	2,39	2,08	1,73	1,65	1,23	1,19	0,84
1,5 m	👤	4,23	4,22	3,64	2,31	2,67	1,68	2,14	2,00	1,88	0,86
	👤	4,18	4,20	2,74	2,20	1,99	1,64	1,58	1,16	1,17	0,84
0,0 m	👤	6,69	3,20	4,11	2,15	3,03	1,55	2,35	1,11	1,63	0,82
	👤	4,39	3,07	2,81	2,07	2,01	1,50	1,45	1,08	1,09	0,80
-1,0 m	👤	7,23	3,14	4,49	2,06	3,18	1,49	2,18	1,08	1,56	0,91
	👤	4,27	3,07	2,73	2,01	1,95	1,44	1,44	1,05	1,17	0,89

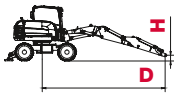

TPA BOOM with dipperstick 2 000 mm, additional counterweight

		D									
		3 m		4 m		5 m		6 m		7 m	
H		👤	👤	👤	👤	👤	👤	👤	👤	👤	👤
		3,0 m	👤	--	--	2,71	2,54	2,26	2,09	2,18	1,34
👤	--		--	2,70	2,50	2,18	1,82	1,73	1,30	1,26	0,90
1,5 m	👤	4,39	4,37	3,76	2,42	2,78	1,77	2,22	1,27	1,95	0,93
	👤	4,34	4,35	2,86	2,32	2,09	1,73	1,66	1,23	1,24	0,90
0,0 m	👤	6,85	3,35	4,23	2,26	3,12	1,64	2,44	1,19	1,71	0,89
	👤	4,54	3,22	2,93	2,19	2,10	1,59	1,53	1,15	1,16	0,87
-1,0 m	👤	7,4	3,29	4,61	2,18	3,28	1,58	2,26	1,15	1,63	0,98
	👤	4,44	3,22	2,86	2,12	2,05	1,53	1,50	1,13	1,24	0,96

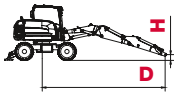

TPA BOOM with dipperstick 2 350 mm

		D											
		3 m		4 m		5 m		6 m		7 m		7,5 m	
H		👤	👤	👤	👤	👤	👤	👤	👤	👤	👤	👤	👤
		3,0 m	👤	--	--	2,70	2,27	2,13	1,64	2,13	1,14	1,92	0,86
👤	--		--	2,20	2,06	1,51	1,46	1,12	1,02	0,86	0,77	--	--
1,5 m	👤	4,77	3,73	2,70	2,16	2,38	1,53	2,39	1,09	1,88	0,83	1,69	0,71
	👤	3,74	3,40	2,16	1,97	1,52	1,39	1,04	0,98	0,87	0,72	0,68	0,62
0,0 m	👤	6,36	3,46	3,40	2,02	2,64	1,43	2,32	1,06	1,73	0,82	1,60	0,73
	👤	3,51	3,17	2,01	1,89	1,41	1,31	1,02	0,97	0,78	0,73	0,70	0,64
-1,0 m	👤	7,12	3,29	3,73	1,84	2,94	1,27	2,26	0,96	1,71	0,80	--	--
	👤	3,29	3,11	1,94	1,73	1,35	1,21	0,99	0,88	0,81	0,75	--	--

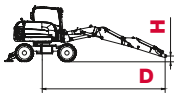

TPA BOOM with dipperstick 2 350 mm, additional counterweight

		D											
		3 m		4 m		5 m		6 m		7 m		7,5 m	
H		👤	👤	👤	👤	👤	👤	👤	👤	👤	👤	👤	👤
		3,0 m	👤	--	--	2,81	2,38	2,22	1,73	2,20	1,21	1,98	0,92
👤	--		--	2,31	2,17	1,60	1,55	1,19	1,09	0,92	0,83	--	--
1,5 m	👤	4,91	3,87	2,81	2,27	2,47	1,62	2,45	1,16	1,94	0,89	1,75	0,77
	👤	3,88	3,54	2,27	2,08	1,61	1,48	1,11	1,05	0,93	0,78	0,74	0,68
0,0 m	👤	6,5	3,60	3,51	2,13	2,73	1,52	2,39	1,13	1,79	0,88	1,66	0,79
	👤	3,65	3,31	2,12	2,00	1,50	1,40	1,09	1,04	0,84	0,79	0,76	0,70
-1,0 m	👤	7,26	3,43	3,84	1,95	3,03	1,36	2,33	1,03	1,77	0,86	--	--
	👤	3,43	3,25	2,05	1,84	1,44	1,30	1,06	0,95	0,87	0,81	--	--

All values in tons (t) were determined acc. to ISO 10567 and include a stability factor of 1.33 or 87% of the hydraulic lifting capacity. All values were determined with loading hook. If a bucket is attached, the difference weights bucket minus loading hook must be deducted from the permissible payloads. When used for loading hook applications, excavators must be equipped with hose-rupture valves and overload warning device in compliance with EN 474-5. Working equipment: Two-piece articulated boom, twin tires.

SPECIFICATIONS

[WEIGHT AND DIMENSIONS]

Operating weight (two-piece articulated boom "TPA") acc. to ISO 6016	11 000 kg
Total length, travel position (TPA boom)	5 860 mm
Total height, travel position (TPA boom)	3 975 mm
Transport dimensions: TPA boom (L x H)	6 800 x 2 990 mm
Ground clearance below cardan shaft	440 mm
Turning radius	7 200 mm
Uppercarriage tailswing	1 600 mm
Uppercarriage frontswing	3 000 mm
Working envelope 180°	4 600 mm
Working envelope 360°	6 000 mm

[ENGINE]

Manufacturer, model	Deutz, TCD3.6 L4
Type	4-cylinder Turbo diesel engine with intercooler - EU Stage V / TIER 4 final
Combustion	4-stroke cycle, Common Rail injection
Displacement	3 600 cm ³
Net power rating at 2000 rpm (ISO 9249)	85 kW (116 HP)
Torque	460 Nm at 1600 rpm
Cooling system	Water

[HYDRAULIC SYSTEM]

Travel hydraulics: Closed circuit, independent from working hydraulics

Pump capacity, max.	180l/min
Working pressure, max.	460 bar

Working hydraulics: Axial-piston variable displacement pump with load sensing, coupled with a load independent flow sharing (LUDV). Simultaneous, independent control of all movements. Sensitive maneuvers irrespective of loads.

Pump capacity, max.	190l/min
Working pressure, max	330 bar

The thermostatically controlled oil circuit ensures that the oil temperature is promptly reached and avoids overheating. Hydraulically driven fan with reversing function. Return filter installed in oil tank allows for eco-friendly replacement of filter elements.

Triple gear pump for all positioning, swing movements and hydrostatic fan.	
Pump capacity, max.	38 + 38 + 38 l/min
Working pressure, max.	250 bar
Control circuit for work attachments (proportionally operated)	
Pump capacity, adjustable	0 - 120 l/min
Working pressure, max.	330 bar

Two servo-assisted joystick controls (ISO) for excavator operations

[TRANSMISSION]

Hydrostatic travel drive in closed circuit with automatic adjustment of drawbar pull and speed irrespective of the working hydraulics.					
4-wheel drive from reduction gear on front axle via cardan shaft to rear axle. Infinitely variable speed control forward and reverse					
2 speed ranges:	"Low"	0-6 km/h	4 speed ranges (high-speed version optional):	"Low"	0-6 / 0-19 km/h
	"High"	0-20 km/h		"High"	0-11 / 0-36 km/h

SPECIFICATIONS

[STANDARD EQUIPMENT]

CABIN

Spacious, sound-insulated full-vision steel cab (ROPS certified). Sliding window in cabin door and right window.

Safety glass windows, thermo windows tinted in green. Skylight thermo window, bronze tinted.

Panoramic rear window.

Front window supported by pneumatic springs, lockable for ventilation and slidable under cab roof.

Windshield washer system.

Storage compartment.

Preparation for radio installation.

Left-hand outside rear-view mirror.

Cabin heating with windshield defroster through coolant heat exchanger with continuous fan. Fresh air and recirculating air filters.

Rearview camera.

Operator's seat MSG 85 (comfort version), hydraulic damping, extra-high backrest, tilt-adjustable armrests, longitudinal-horizontal suspension, mechanical lumbar support. Lap belt.

Instrument panel on the right hand side of the operator's seat with visual & acoustic warning device, hour-meter and safety module.

Working flood lights LED

Sound level values (in compliance with Directive 2000/14/EC and EN474).

Sound power level : LWA 100 dB (A).

Sound pressure level : LpA 70 dB (A).

Effective values of acceleration (in compliance with Directive 2006/42/EC and EN474).

Whole body : less than 0.5 m/s².

Hand-arm : less than 2.5 m/s²

AXLES

Front: oscillating planetary drive axle.

Oscillating angle 13°

Rear rigid planetary drive axle.

STEERING

Fully hydraulically controlled front axle with integrated steering cylinder.

Max. steering angle.

30°

SWING SYSTEM

Hydrostatic drive with 2-stage planetary gear and axial piston fixed displacement motor, also acts as wear-resistant brake.

In addition, automatically controlled spring-loaded multi-disc brake acting as parking brake.

Swing speed.

0-10 rpm

KNICKMATIK®

Lateral parallel adjustment of boom arrangement at full digging depth.

Angle of articulation / lateral adjustment left.

54° / 760 mm

Angle of articulation / lateral adjustment right.

54° / 1 030 mm

ELECTRICAL SYSTEM

Nominal voltage

12 V

Battery

12 V / 135 Ah

Generator

14 V / 95 Ah

Starter

12 V / 4,0 kW

FLUID CAPACITIES

Fuel tank

185 l

AdBlue tank

10 l

Hydraulic system (incl. tank 160 l)

230 l

BRAKES

Service brake: Hydraulic pump accumulator two-circuit brake, acting on oil-immersed multi-disc brakes of front and rear axle.

Excavator brake: Acting on front and rear axle due to lockable service brake.

Auxiliary brake: Hydrostatic travel drive in closed circuit acting as non-wearing auxiliary brake.

Parking brake: Hydraulic spring-loaded brake, electrically actuated.

TIRES

Standard 9.00-20, 14 PR twin tires

MAINTENANCE FREQUENCY

Change engine oil and filter:

500h or minimum once a year.

Change fuel filter:

1 000h or minimum once a year

Change hydraulic oil:

check at 100 + 500 h; every 1 000h or minimum every 2 years.

Change hydraulic oil filter:

first after 100h, then follow the instructions at display.

Change cooling fluid:

if needed or minimum every 2 years.

SPECIFICATIONS

[OPTIONAL EQUIPMENT]

CABIN

Several LED lighting options available | FOPS - skylight guard | Yellow beacon | Protection grid front window

BOOM OPTIONS

TPA boom, with dipperstick 2000 mm | TPA boom, with dipperstick 2350 mm.

TIRES

600/40-22.5 (single wide-base tires) | 315/70 R 22.5 (twin tires).

HYDRAULIC SYSTEM

Hydraulic installation for quick-hitch system | Biodegradable hydraulic oil / ester-based HLP 68 (Panolin) | Float position - dozer blade | 2nd and 3rd additional auxiliary hydraulic circuit, with proportional control and flow setting in display, including connectors at arm end | Switchover from ISO controls to SAE controls | Bucket control change-over (in case of forklift operation) | Hose-rupture / load-retaining valves for bucket cylinder.

OPERATOR'S STAND

Operator's seat MSG 95 (premium version), air damping, extra-high backrest and tilt-adjustable armrests, longitudinal/horizontal suspension, seat and backrest heating, pneumatic lumbar support | Climatronic | Thermoelectric cooler box.

ENGINE

Automatic idling system | Automatic engine shutdown

OPTIONAL SUPPORT/DOZER SYSTEMS

Rear support blade, 2500 mm wide, incl. outrigger legs | Rear outrigger plates, flat, oscillating, incl. outrigger legs | Rear outrigger plates, rubber-coated, oscillating, incl. outrigger legs | Front dozer blade, 2500 mm wide.

OTHER OPTIONAL EQUIPMENT

4 wheel steering with switchover from 4WS to crab steering | Steering change-over in case of blade operation | Quick-hitch system, mechanical, type MS08 | Quick-hitch system, hydraulic, type HS08 | Anti-theft device (immobilizer) | Approval package for high-speed version | Additional tool box | Engine-independent diesel heater with fresh air circulation and timer | Additional rear weight, 350 kg | Electrical refueling pump | Further optional equipment available on request.

[ATTACHMENTS]

We offer a range of factory fitted attachments to maximize the versatility of your wheeled excavator.



YANMAR



Yanmar Compact Equipment EMEA

GB_B110W_0724



www.yanmar.com

BUILDING
WITH YOU

Printed in France - Materials and specifications are subject to change from the manufacturer without notice - Please contact your local Yanmar Compact Equipment EMEA dealer for further information. This digital leaflet is not intended for printing.