

**YANMAR**

OPERATION MANUAL

# MARINE ENGINE

**6LPA-STP2  
6LPA-STZP2**

**en** English

**Disclaimers:**

All information, illustrations and specifications in this manual are based on the latest information available at the time of publishing. The illustrations used in this manual are intended as representative reference views only. Moreover, because of our continuous product improvement policy, we may modify information, illustrations and/or specifications to explain and/or exemplify a product, service or maintenance improvement. We reserve the right to make any change at any time without notice. Yanmar and **YANMAR** are registered trademarks of YANMAR CO., LTD. in Japan and/or other countries.

**All Rights Reserved:**

No part of this publication may be reproduced or used in any form by any means - graphic, electronic, or mechanical, including photocopying, recording, taping, or information storage and retrieval systems - without the written permission of YANMAR CO., LTD.

OPERATION MANUAL	MODEL	6LPA-STP2, 6LPA-STZP2
	CODE	0A6LP-G00103

# TABLE OF CONTENTS

---

	Page
<b>INTRODUCTION</b> .....	1
Record of Ownership .....	2
<b>SAFETY</b> .....	3
<b>SAFETY PRECAUTIONS</b> .....	4
General Information .....	4
Before You Operate .....	4
During Operation and Maintenance .....	4
<b>LOCATION OF SAFETY DECALS</b> .....	8
<b>PRODUCT OVERVIEW</b> .....	9
<b>YANMAR 6LPA SERIES FEATURES AND APPLICATIONS</b> .....	9
New Engine Break-In .....	10
<b>COMPONENT IDENTIFICATION</b> .....	11
Service Side (Left Side as Viewed from Propeller) .....	11
Non-Service Side .....	12
<b>NAMEPLATES</b> .....	13
<b>FUNCTION OF MAJOR COMPONENTS</b> .....	14
<b>CONTROL EQUIPMENT</b> .....	15
Instrument Panel (Optional) .....	15
Remote Control (Throttle) Handle .....	21
<b>BEFORE YOU OPERATE</b> .....	25
<b>INTRODUCTION</b> .....	25
<b>SAFETY PRECAUTIONS</b> .....	25

# TABLE OF CONTENTS

---

DIESEL FUEL.....	26
Diesel Fuel Specifications .....	26
Handling of Diesel Fuel .....	27
Fuel Tank (Optional) .....	28
Fuel System .....	28
Filling the Fuel Tank.....	28
Bleeding the Fuel System .....	29
ENGINE OIL .....	30
Engine Oil Specifications .....	30
Engine Oil Viscosity .....	31
Checking the Engine Oil.....	31
Adding Engine Oil .....	31
MARINE DRIVE OIL.....	32
Mercruiser® Bravo Stern Drive Oil Specifications .....	32
Checking and Adding Marine Drive Oil .....	32
Checking and Adding Power Steering Oil (6LPA-STZP2 Models) .....	33
ENGINE COOLANT .....	33
Engine Coolant Specifications .....	33
Coolant (Closed Cooling System) .....	34
Checking and Adding Coolant.....	34
CRANKING THE ENGINE .....	36
<b>ENGINE OPERATION .....</b>	<b>37</b>
INTRODUCTION .....	37
SAFETY PRECAUTIONS.....	37
STARTING THE ENGINE .....	39
If the Engine Fails to Start.....	40
Starting at Low Temperatures.....	41
After the Engine has Started.....	42
REMOTE CONTROL HANDLE OPERATION .....	43
Acceleration and Deceleration .....	43
Shifting the Engine .....	44
CAUTIONS DURING OPERATION.....	45
SHUTTING DOWN THE ENGINE .....	46
Normal Shutdown.....	46
CHECKING THE ENGINE AFTER OPERATION.....	47
<b>PERIODIC MAINTENANCE .....</b>	<b>49</b>
INTRODUCTION .....	49
SAFETY PRECAUTIONS.....	49

PRECAUTIONS .....	51
The Importance of Periodic Maintenance .....	51
Performing Periodic Maintenance .....	51
The Importance of Daily Checks .....	51
Keep a Log of Engine Hours and Daily Checks .....	51
Yanmar Replacement Parts .....	51
Tools Required .....	51
Ask Your Authorized Yanmar Marine Dealer or Distributor for Help .....	51
Tightening Fasteners .....	52
PERIODIC MAINTENANCE SCHEDULE .....	53
PERIODIC MAINTENANCE PROCEDURES .....	56
Daily Checks .....	56
After Initial 50 Hours of Operation .....	57
Every 50 Hours of Operation .....	60
Every 125 Hours of Operation .....	62
After Initial 250 Hours of Operation .....	62
Every 250 Hours of Operation .....	63
Every 500 Hours of Operation .....	65
Every 1000 Hours of Operation .....	67
Every 1250 Hours of Operation .....	68
<b>TROUBLESHOOTING</b> .....	69
SAFETY PRECAUTIONS .....	69
TROUBLESHOOTING AFTER STARTING .....	69
TROUBLESHOOTING INFORMATION .....	70
TROUBLESHOOTING CHART .....	71
<b>LONG-TERM STORAGE</b> .....	73
PREPARE ENGINE FOR LONG-TERM STORAGE .....	73
DRAIN SEAWATER COOLING SYSTEM .....	74
RETURNING THE ENGINE TO SERVICE .....	75
<b>SPECIFICATIONS</b> .....	77
PRINCIPAL ENGINE SPECIFICATIONS .....	78
Marine Drive Specifications (Optional) .....	79
<b>SYSTEM DIAGRAMS</b> .....	81
PIPING DIAGRAMS .....	81
WIRING DIAGRAMS .....	87

**This Page Intentionally Left Blank**

# INTRODUCTION

---

Welcome to the world of Yanmar Marine! Yanmar Marine offers engines, drive systems and accessories for all types of boats, from runabouts to sailboats, and from cruisers to mega yachts. In marine leisure boating, the worldwide reputation of Yanmar Marine is second to none. We design our engines to respect nature. This means quieter engines, with minimal vibrations, cleaner than ever. All of our engines meet applicable regulations, including emissions, at the time of manufacture.

To help you enjoy your Yanmar 6LPA series engine for many years to come, please follow these recommendations:

- Read and understand this *Operation Manual* before you operate the machine to ensure that you follow safe operating practices and maintenance procedures.
- Keep this *Operation Manual* in a convenient place for easy access.
- If this *Operation Manual* is lost or damaged, order a new one from your authorized Yanmar Marine dealer or distributor.
- Make sure this manual is transferred to subsequent owners. This manual should be considered a permanent part of the engine and remain with it.
- Constant efforts are made to improve the quality and performance of Yanmar products, so some details included in this *Operation Manual* may differ slightly from your engine. If you have any questions about these differences, please contact your authorized Yanmar Marine dealer or distributor.
- The specifications and components (instrument panel, fuel tank, etc.) described in this manual may differ from ones installed on your vessel. Please refer to the manual provided by the manufacturer of these components.
- Refer to the Yanmar Limited Warranty Handbook for a complete warranty description.

## INTRODUCTION

---

### RECORD OF OWNERSHIP

Take a few moments to record the information you need when you contact Yanmar for service, parts or literature.

**Engine Model:** \_\_\_\_\_

**Engine Serial No.:** \_\_\_\_\_

**Date Purchased:** \_\_\_\_\_

**Dealer:** \_\_\_\_\_

**Dealer Phone:** \_\_\_\_\_



# SAFETY

---

Yanmar considers safety of great importance and recommends that anyone that comes into close contact with its products, such as those who install, operate, maintain or service Yanmar products, exercise care, common sense and comply with the safety information in this manual and on the machine's safety decals. Keep the labels from becoming dirty or torn and replace them if they are lost or damaged. Also, if you need to replace a part that has a label attached to it, make sure you order the new part and label at the same time.



This safety alert symbol appears with most safety statements. It means attention, become alert, your safety is involved! Please read and abide by the message that follows the safety alert symbol.

## DANGER

Indicates a hazardous situation which, if not avoided, *will* result in death or serious injury.

## WARNING

Indicates a hazardous situation which, if not avoided, *could* result in death or serious injury.

## CAUTION

Indicates a hazardous situation which, if not avoided, *could* result in minor or moderate injury.

## NOTICE

Indicates a situation which can cause damage to the machine, personal property and / or the environment, or cause the equipment to operate improperly.

## SAFETY PRECAUTIONS

### General Information

There is no substitute for common sense and careful practices. Improper practices or carelessness can cause burns, cuts, mutilation, asphyxiation, other bodily injury or death. This information contains general safety precautions and guidelines that must be followed to reduce risk to personal safety. Special safety precautions are listed in specific procedures. Read and understand all of the safety precautions before operation or performing repairs or maintenance.

### Before You Operate

#### DANGER

The safety messages that follow have DANGER level hazards.



**NEVER** permit anyone to install or operate the engine without proper training.

Read and understand this *Operation Manual* before you operate or service the engine to ensure that you follow safe operating practices and maintenance procedures.

- Safety signs and labels are additional reminders for safe operating and maintenance techniques.
- See your authorized Yanmar Marine dealer or distributor for additional training.

### During Operation and Maintenance

#### WARNING

The safety messages that follow have WARNING level hazards.

#### Explosion Hazard



While the engine is running or the battery is charging, hydrogen gas is being produced and can be easily ignited. Keep the area around the battery

well-ventilated and keep sparks, open flames and any other form of ignition out of the area.

#### Fire and Explosion Hazard

Diesel fuel is flammable and explosive under certain conditions.

**NEVER** use a shop rag to catch the fuel.

Wipe up all spills immediately.

**NEVER** refuel with the engine running.

#### Fire Hazard



Undersized wiring systems can cause an electrical fire.

Store any containers containing fuel or other flammable products in a well-ventilated area, away from any combustibles or source of ignition.

Store any equipment in a designated area away from moving parts.

**NEVER** use the engine compartment for storage.

**⚠ WARNING****Sever Hazard**

Rotating parts can cause severe injury or death. NEVER wear jewelry, unbuttoned cuffs, ties or loose-fitting clothing and

ALWAYS tie long hair back when working near moving / rotating parts such as the flywheel or PTO shaft. Keep hands, feet and tools away from all moving parts.

**Alcohol and Drug Hazard**

NEVER operate the engine while under the influence of alcohol or drugs, or when feeling ill.

**Exposure Hazard**

ALWAYS wear personal protective equipment including appropriate clothing, gloves, work

shoes, and eye and hearing protection as required by the task at hand.

**Sudden Movement Hazard**

NEVER operate the engine while wearing a headset to listen to music or radio because it will be difficult to hear the warning signals.

**Burn Hazard**

Some of the engine surfaces become very hot during operation and shortly after shutdown.

Keep hands and other body parts away from hot engine surfaces.

**Exhaust Hazard**

NEVER block windows, vents or other means of ventilation if the engine is operating in an enclosed area. All internal combustion engines create carbon monoxide gas during operation and special precautions are required to avoid carbon monoxide poisoning.

## CAUTION

The safety messages that follow have CAUTION level hazards.

### **Poor Lighting Hazard**

Ensure that the work area is adequately illuminated. ALWAYS install wire cages on portable safety lamps.

### **Tool Hazard**

ALWAYS use tools appropriate for the task at hand and use the correct size tool for loosening or tightening machine parts.

### **Flying Object Hazard**

ALWAYS wear eye protection when servicing the engine or when using compressed air or high-pressure water. Dust, flying debris, compressed air, pressurized water or steam may injure your eyes.

### **Coolant Hazard**



Wear eye protection and rubber gloves when you handle engine coolant. If contact with the eyes or skin should occur, flush eyes and wash immediately with clean water.

## NOTICE

The safety messages that follow have NOTICE level hazards.

It is important to perform daily checks as listed in the *Operation Manual*. Periodic maintenance prevents unexpected downtime, reduces the number of accidents due to poor engine performance and helps extend the life of the engine.

See your authorized Yanmar Marine dealer or distributor if you need to operate the engine at high altitudes. At high altitudes the engine will lose power, run rough and produce exhaust gases that exceed the design specifications.



ALWAYS be environmentally responsible.

Follow the guidelines of your country's governmental agencies for the proper disposal of hazardous materials such as engine oil, diesel fuel and engine coolant. Consult the local authorities or reclamation facility.

NEVER dispose of hazardous materials by dumping them into a sewer, on the ground, or into ground water or waterways.

If a Yanmar Marine Engine is installed at an angle that exceeds the specifications stated in the Yanmar Marine *Installation Manuals*, engine oil may enter the combustion chamber causing excessive engine speed, white exhaust smoke and serious engine damage. This applies to engines that run continuously or those that run for short periods of time.

**NOTICE**

If you have an installation with two or three engines and only one engine is operating, the water pickup (thru-hull) of the non-running engine(s) should be closed. This will prevent water from being forced past the seawater pump and eventually finding its way into the engine. The result of water entering the engine could cause seizure or other serious problems.

If you have an installation with two or three engines, and only one engine is operating, please note that if the propeller shaft thru-hull (stuffing box) is lubricated by engine water pressure and the engines are interconnected, care must be taken that water from the running engine does not enter the exhaust of the non-running engine(s). This water could cause seizure of the non-running engine(s). See your authorized Yanmar Marine dealer or distributor for a complete explanation of this condition.

If you have an installation with two or three engines, and only one engine is operating, it is important to limit the amount of throttle applied to the running engine. If you observe black smoke or movement of the throttle does not increase engine speed, you are overloading the engine that is running. Immediately throttle back to approximately 2/3 throttle or to a setting where the engine performs normally. Failure to do so may cause the running engine to overheat or cause excess carbon buildup which may shorten the engine's life.

NEVER turn off the battery switch (if equipped) or short the battery cables during operation. Damage to the electrical system will result.

## LOCATION OF SAFETY DECALS

Figure 1 show the location of safety decals on Yanmar 6LPA series marine engines.

## 6LPA Engines

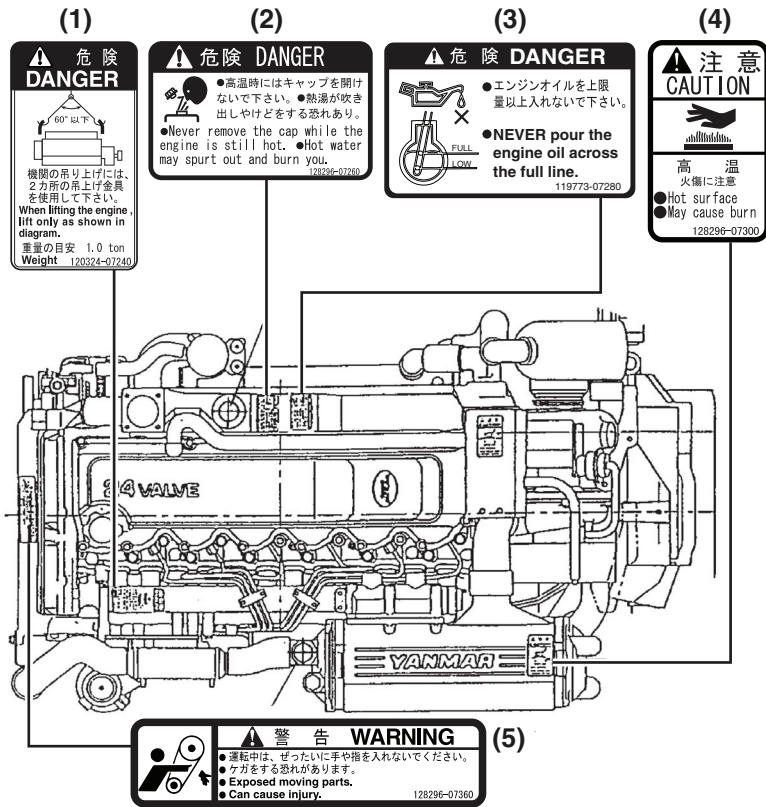

0004813

Figure 1

- 1 – Part Number: 120324-07240
- 2 – Part Number: 128296-07260
- 3 – Part Number: 119773-07280

- 4 – Part Number: 128296-07300
- 5 – Part Number: 128296-07360

# PRODUCT OVERVIEW

---

## YANMAR 6LPA SERIES FEATURES AND APPLICATIONS

The 6LPA series are four-stroke direct injection diesel engines equipped with liquid coolant systems.

The 6LPA-STP2 engines are equipped with a marine gear (ZF63A1 or KMH50A, KMH50V).

The 6LPA-STZP2 engines are equipped with a stern drive (ZT370, Mercruiser Bravo).

These engines are designed for pleasure craft use.

The engines are equipped with a marine gear or sail drive unit.

These engines are designed for pleasure craft use.

It is recommended that new vessels be propped so the engines can operate at 50 to 100 min<sup>-1</sup> above the fuel stop power engine speed to allow for some added weight and hull resistance.

Failure to do so can lead to reduced vessel performance, lead to increased smoke levels and cause permanent damage to your engine.

The engine must be installed correctly with coolant lines, exhaust gas lines and electrical wiring. Any auxiliary equipment attached to the engine should be easy to use and accessible for service. To handle the drive equipment, propulsion systems (including the propeller) and other inboard equipment, always observe the instructions and cautions given in the operation manuals supplied by the shipyard and equipment manufacturers.

The 6LPA series engines are designed to be operated at maximum throttle (3800 min<sup>-1</sup>) for less than 5% of total engine time (30 minutes out of every 10 hours) and cruising speed (2800 min<sup>-1</sup> or less) for less than 90% of total engine time (9 hours out of every 10 hours).

The laws of some countries may require hull and engine inspections, depending on the use, size and cruising area of the boat. The installation, fitting and surveying of this engine all require specialized knowledge and engineering skills. See Yanmars local subsidiary in your region or your authorized Yanmar Marine dealer or distributor.

# PRODUCT OVERVIEW

---

## New Engine Break-In

As with all reciprocating engines, the way your engine is operated during its first 50 hours of operation plays a very significant role in determining how long it will last and how well the engine will perform over its lifetime.

A new Yanmar diesel engine must be operated at suitable speeds and power settings during the break-in period to make the sliding parts, such as piston rings, break-in properly and to stabilize engine combustion.

During the break-in period, the engine coolant temperature gauge should be monitored; temperature should be between 71° and 87°C (160° and 190°F).

During the first 10 hours of operation, the engine should be run at maximum engine speed minus 400 to 500 min<sup>-1</sup> (approximately 60 to 70% of load) most of the time. This will ensure the sliding parts break in properly. During this period, avoid operating at maximum engine speed and load to avoid damaging or scoring sliding parts.

### NOTICE

Do not operate at WOT (wide open throttle) for more than a minute at a time during the first 10 hours of operation.

---

Do not operate the engine at low idle or at low speed and light load for more than 30 minutes at a time. Since unburned fuel and engine oil will adhere to the piston rings when operating at low speeds for long periods, this will interfere with proper movement of the rings and the engine oil consumption may increase. Low idle speed does not allow break-in of sliding parts.

If operating engine at low speed and light load, you must race the engine to clean the carbon from the cylinders and fuel injection valve.

Perform this procedure in open waters:

- With the clutch in NEUTRAL, accelerate from the low-speed position to the high-speed position briefly.
- Repeat this process five times.

Once past the initial 10 hours until 50 hours, the engine should be used over its full operating range, with special emphasis on running at relatively high power settings. This is not the time for an extended cruise at idle or low speed. The boat should be run at maximum speed minus 400 min<sup>-1</sup> most of the time (approximately 70% load), with a 10 minute run at maximum minus 200 min<sup>-1</sup> (approximately 80% load) every 30 minutes and a 4 to 5 minute period of operation at WOT (wide open throttle) once each 30 minutes. During this period, be sure not to operate your engine at low speed and light load for more than 30 minutes. If operating engine at low speed and light load by necessity, just after the low idle operation, be sure to race the engine.

To complete engine break-in, perform *After Initial 50 Hours of Operation* maintenance procedures. See *After Initial 50 Hours of Operation* on page 57.



## COMPONENT IDENTIFICATION

### Service Side (Left Side as Viewed from Propeller)

Note: 6LPA-STZP2 with stern drive shown. Components marked with an \* are for 6LPA-STZP2 only.

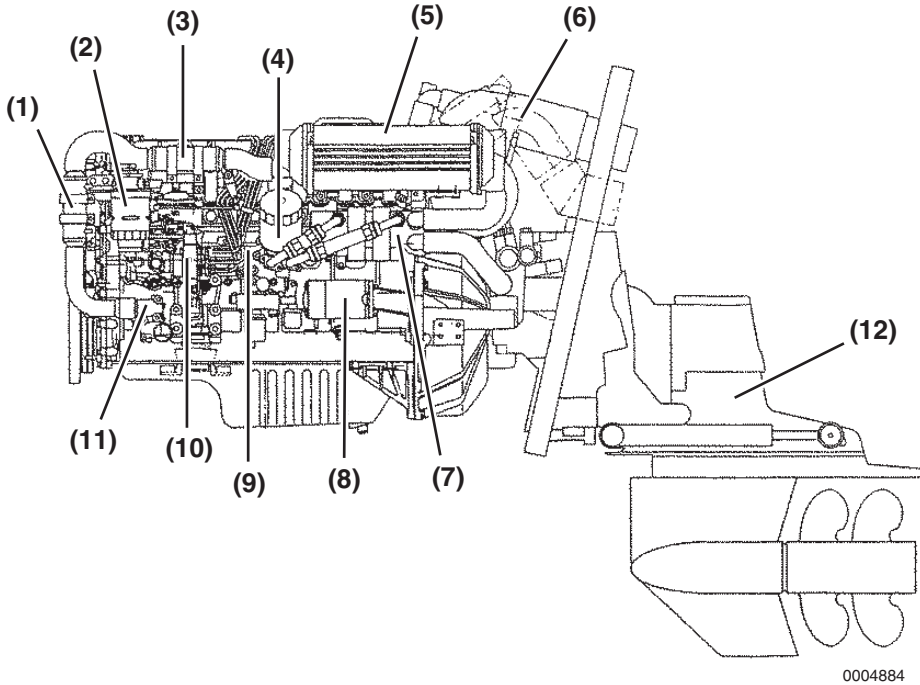
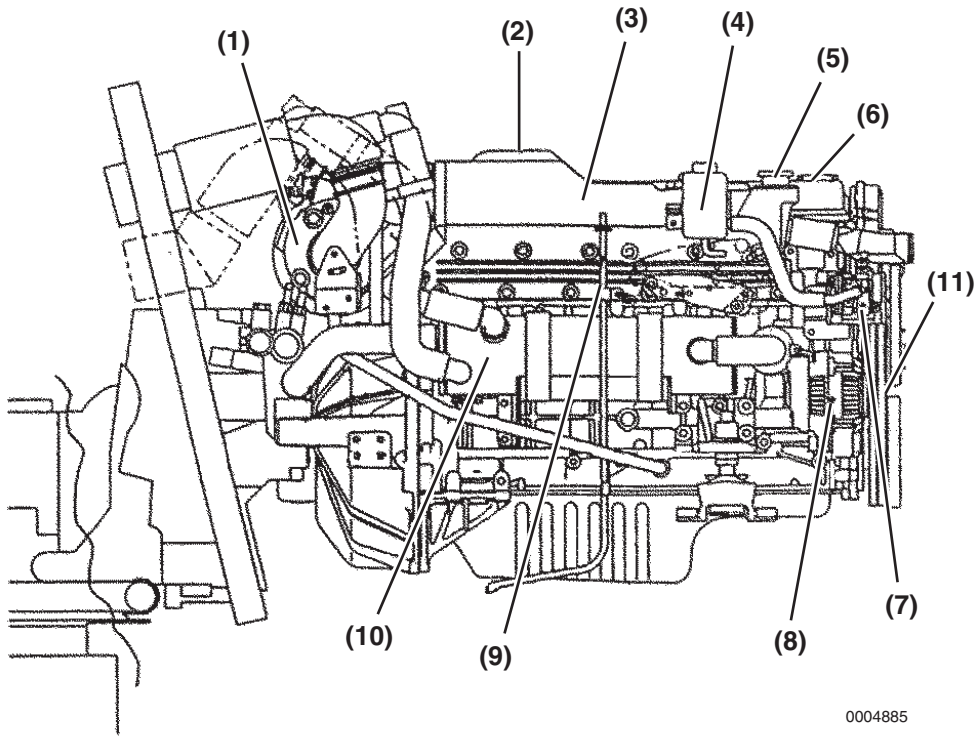

*Figure 1*

- |                                |                          |
|--------------------------------|--------------------------|
| 1 – Fuel Cooler                | 7 – Engine Oil Cooler    |
| 2 – Fuel Filter                | 8 – Starter              |
| 3 – Power Steering Oil Cooler* | 9 – Engine Oil Cooler    |
| 4 – Engine Oil Filter          | 10 – Fuel Injection Pump |
| 5 – Intercooler                | 11 – Seawater Pump       |
| 6 – Mixing Elbow               | 12 – Stern Drive         |

# PRODUCT OVERVIEW

## Non-Service Side



0004885

*Figure 2*

- |  |                              |
|--|------------------------------|
| 1 – Turbocharger                           | 6 – Engine Oil Filler Cap    |
| 2 – Engine Nameplate (on rocker arm cover) | 7 – Power Steering Oil Pump* |
| 3 – Fresh Water (Coolant) Tank             | 8 – Alternator               |
| 4 – Power Steering Oil Tank*               | 9 – Engine Oil Dipstick      |
| 5 – Fresh Water Filler Cap                 | 10 – Fresh Water Cooler      |
|  | 11 – V-Belt                  |

## NAMEPLATES

The nameplate of Yanmar 6LPA series engines is shown in **Figure 3**. The nameplate is located on the engine rocker arm cover. Check the engine's model, output, rpm and serial number on the nameplate. Replace if damaged or lost.

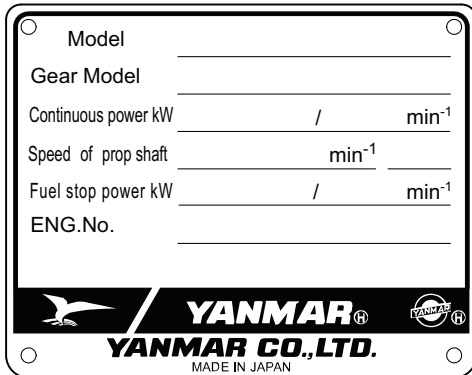

0004574

**Figure 3**

# PRODUCT OVERVIEW

## FUNCTION OF MAJOR COMPONENTS

Name of Component	Function
Fuel Filter	Removes dirt and water from the fuel. The filter is a cartridge type, and the inner element should be replaced before clogging occurs. A water separator is on the bottom of the filter and should be drained periodically.
Fuel Feed Pump	A mechanical pump that pumps fuel from the tank to the fuel injection pump. It is built in to the fuel injection pump.
Fuel Bleed Pump	This is a manual fuel pump. Pushing the knob on the top of the fuel filter feeds the fuel. The pump is also used to bleed air from the fuel system.
Engine Oil Filler Port	Filler port for engine oil.
Engine Oil Filter	Filters fine metal fragments and carbon from the engine oil. Filtered engine oil is distributed to the engine's moving parts. The filter is a cartridge type and should be replaced periodically.
Engine Oil Dipstick	Gauge stick for checking the engine oil level.
Marine Gear Oil Filler Port (If Equipped)	Filler port for marine gear lube oil. Located on top of the marine gear case.
Cooling System	There are two cooling systems: coolant and seawater.
<ul style="list-style-type: none"><li>• Coolant Tank</li><li>• Heat Exchanger</li><li>• Coolant Pump</li></ul>	The tank stores the coolant and is connected to the heat exchanger. Cooling seawater passes through the heat exchanger to cool the coolant by heat exchange. After cooling, the coolant is fed by the coolant pump to the inside of the engine, around the combustion chamber, turbocharger and then returned to the tank.
Filler Cap	Located on the top of the coolant tank. It has two pressure regulating valves (release and retraction valves). When the coolant temperature rises, the pressure inside the coolant tank increases causing the release valve in the filler cap to open.
Reservoir	Hot water and steam pass through a rubber hose to the reservoir for cooling. (The filler port and the reservoir are connected by a rubber hose.) When the load is reduced and the coolant temperature falls, the pressure in the coolant tank is lowered, activating the retraction valve in the filler cap. This causes the coolant in the reservoir to return to the coolant tank. This process reduces the consumption of coolant.
Turbocharger	A pressurized intake air feeding device. The exhaust gas turbine is rotated by the exhaust gas and the power is used to rotate the blower. This pressurizes the intake air for sending to the cylinder.
Charge air cooler	This heat exchanger cools the pressurized charging air from the turbocharger with water.
Zinc Anode	The metal area of the seawater cooling system is prone to galvanic corrosion. The zinc anode is installed in the various coolers to prevent this. When the zinc anode becomes worn, components in the fresh water cooler, oil cooler, etc. will corrode. Periodic replacement of the zinc anode is necessary.
Nameplates	Nameplates are provided on the engine and have the model, serial number and other data.
Starter	A DC motor for starting the engine. Electric current causes the pinion gear to engage with the ring gear on the flywheel to start the engine.
Alternator	This generator rotates by a V-belt drive to charge the battery during operation.

## CONTROL EQUIPMENT

The control equipment at the helm makes remote control operation possible. It consists of the instrument panel, which is connected to the engine by a wire harness, and the remote control (throttle) handle, which is connected by control cables to the engine control lever.

### Instrument Panel (Optional)

#### Equipment and Functions

The instrument panel has the following gauges and alarm devices.

○ = Available, — = Not Available

Gauge or Switch		New B-Type Panel See (Figure 3)	New C-Type Panel See (Figure 4)	New D-Type Panel See (Figure 5)
Switches	Key (Starter) Switch	○	○	○
	Engine Stop Button	○	○	○
	Alarm (Buzzer)	○	○	○
	Alarm (Buzzer) Stop Switch	○	○	○
	Backlight Switch for Gauges	○	○	○
Warning Indicators	Battery Low Charge	○	○	○
	Fresh Water (Coolant) High Temperature	○	○	○
	Engine (Lube) Oil Low Pressure	○	○	○
	Fresh Water (Coolant) Level	—	○	○
	Exhaust (Cooling Seawater Flow)	○	○	○
	Fuel Filter (Water Separator)	○	○	○
	Gear Oil (6LPA-STZP2 Only)	—	○	○
Gauges	Tachometer with Hourmeter	○	○	○
	Engine (Lube) Oil Pressure Gauge	—	○	○
	Fresh Water (Coolant) Temperature Gauge	—	○	○
	Turbocharger Boost Pressure Gauge	—	—	○
Clock	Quartz Clock	○ (Option)	○ (Option)	○
Indicator	Preheat Indicator	○ (Option)	○ (Option)	○

**New B-Type**

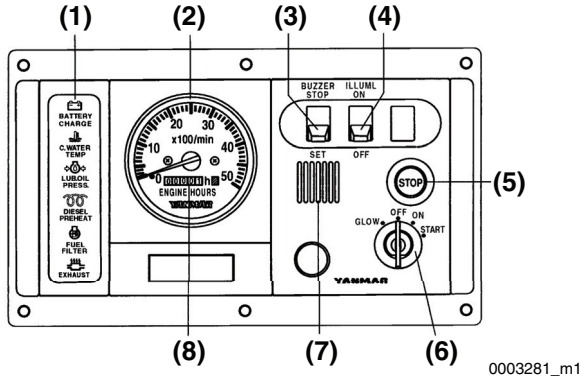

**Figure 4**

- |                                      |                                 |
|--------------------------------------|---------------------------------|
| <b>1 – Warning Indicator Display</b> | <b>5 – Engine Stop Button</b>   |
| <b>2 – Tachometer</b>                | <b>6 – Starter (Key) Switch</b> |
| <b>3 – Alarm Stop Switch</b>         | <b>7 – Alarm</b>                |
| <b>4 – Panel Illumination Switch</b> | <b>8 – Hourmeter</b>            |

**New C-Type**

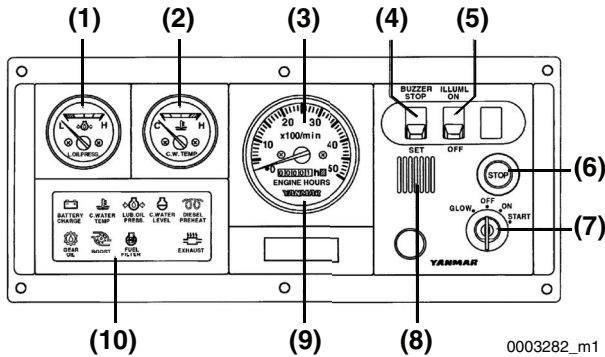

**Figure 5**

- |  |                                       |
|--|---------------------------------------|
| <b>1 – Engine Oil Pressure Gauge</b>               | <b>5 – Panel Illumination Switch</b>  |
| <b>2 – Fresh Water (Coolant) Temperature Gauge</b> | <b>6 – Engine Stop Button</b>         |
| <b>3 – Tachometer</b>                              | <b>7 – Start (Key) Switch</b>         |
| <b>4 – Alarm Stop Switch</b>                       | <b>8 – Alarm</b>                      |
|  | <b>9 – Hourmeter</b>                  |
|  | <b>10 – Warning Indicator Display</b> |

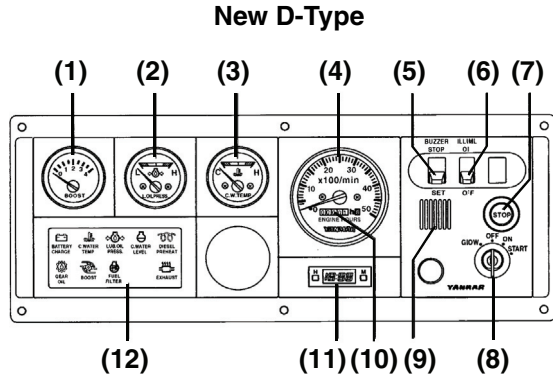

0003283\_m1

Figure 6

- |   |   |
|---|---|
| <p>1 – Turbocharger Boost Pressure Gauge</p> <p>2 – Engine Oil Pressure Gauge</p> <p>3 – Fresh Water (Coolant) Temperature Gauge</p> <p>4 – Tachometer</p> <p>5 – Alarm Stop Switch</p> | <p>6 – Panel Illumination Switch</p> <p>7 – Engine Stop Button</p> <p>8 – Start (Key) Switch</p> <p>9 – Alarm</p> <p>10 – Hourmeter</p> <p>11 – Clock</p> <p>12 – Warning Indicator Display</p> |
|---|---|

Available Alarm Switches and Meter Senders

		○ = Standard, □ = Optional	
		<b>6LPA-STP2, 6LPA-STZP2</b>	
Switches	Battery Not Charging	○	
	Fresh Water (Coolant) Temperature Too High	○	
	Engine (Lube) Oil Pressure Too Low	○	
	Fresh Water (Coolant) Level Too Low	□	
	Exhaust (Cooling Seawater Flow) Restriction	□	
	Gear Oil (Stern Drive Models Only)	□	
	Fuel Filter	○	
Senders	Tachometer	○	
	Fresh Water (Coolant) Temperature	□	
	Engine (Lube) Oil Pressure	□	
	Boost Pressure	□	
	Fresh Water (Coolant) Temperature	For two stations	□
	Engine (Lube) Oil Pressure		□

# PRODUCT OVERVIEW

## Switches and Gauges

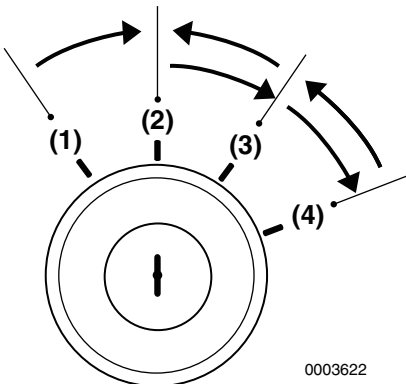
Switch or Gauge	Function
 <p>0003622</p> <p>Starter (Key) Switch</p>	<p>OFF (2): The key can be inserted or removed from switch. All power is turned off. *</p> <p>ON (3): For engine operation. Gauges and alarms are operational.</p> <p>START (4): For starting engine. When key is released after engine starts, key automatically moves to ON position.</p> <p><b>NOTICE</b></p> <p>NEVER hold the key in the START position for longer than 15 seconds or the starter motor will overheat.</p> <p>GLOW (1): For air heater (optional).</p>
Engine Stop Button	Press the button to stop the engine by cutting off the fuel flow. Continue to press the button until the engine has stopped. **
Warning Alarm (Buzzer)	The alarm sounds if an abnormality is detected. <i>See Warning Devices on page 19.</i>
Warning Indicators	The lamps illuminate when an abnormality is detected. <i>See Warning Devices on page 19.</i>
Alarm (Buzzer) Stop Switch	The switch is used to shut the alarm off temporarily. Turn the alarm (buzzer) OFF when inspecting for cause.
	<p><b>WARNING</b></p> <p><b>Inspect and repair the abnormality immediately.</b></p>
Backlight Switch	Turns instrument panel backlighting OFF or ON.
Hourmeter	Shows the total number of operating hours. Can be used as a guide for periodic maintenance checks. The hourmeter is located at the bottom of the tachometer.
Engine (Lube) Oil Pressure Gauge	Shows the engine (lube) oil pressure.
Fresh Water (Coolant) Temperature Gauge	Shows the cooling fresh water temperature.
Turbocharger Boost Pressure Gauge	Shows the intake pressure (intake air boost pressure of turbocharger).
Preheat Indicator (If equipped)	Illuminates when the air heater is heating up for easier starting in cold temperatures. Indicator is located in the warning lamp cluster.

\* The engine cannot be stopped by the starter (key) switch. Use the engine stop button to turn engine OFF.

\*\* Releasing the engine stop button before the engine has stopped rotating will cause the engine to continue to run.



## Warning Devices

When a sensor detects a problem during operation, the indicator on the instrument panel will light and an alarm will sound. Indicators are located on the instrument panel, the alarm is located on the back of the panel. Under normal operating conditions, the indicators are off.

- Alarm (Buzzer): If a warning lamp illuminates, the alarm will sound. However, no alarm will sound when the battery charging lamp illuminates.
- Alarm (Buzzer) Stop Switch: When investigating the cause of an alarm, press the alarm (buzzer) stop switch.

### WARNING

The switch is used to shut the alarm off temporarily. Turn the alarm (buzzer) OFF when inspecting for cause. Inspect and repair the abnormality immediately.

- Warning Indicators: When operation is normal, the warning indicators are OFF. If an abnormality is detected, the sensor will trigger the appropriate warning indicator to light.



#### Battery Low Charge Indicator

When the alternator output is too low, the indicator will light. When charging begins, the indicator will turn off. No alarm will sound for low battery charge.



#### Fresh Water (Coolant) High Temperature Indicator and Alarm

When the coolant temperature reaches the maximum allowable temperature (95°C [203°F] or higher), the indicator will light and the alarm will sound. Continuing operation at temperatures exceeding the maximum limit will result in damage and seizure. Check the load and troubleshoot the fresh water cooling system.



#### Engine (Lube) Oil Low Pressure Indicator and Alarm

When the engine oil pressure falls below the specified level, the oil pressure sensor will send a signal to the indicator causing it to light and the alarm to sound. Stop operation immediately to avoid damage to the engine. Check the oil level and troubleshoot the lubrication system.

# PRODUCT OVERVIEW



0004882

## Fresh Water (Coolant) Level Indicator and Alarm

When the amount of cooling water in the fresh water recovery tank falls below normal, the sensor will send a signal to the indicator causing it to light and the alarm to sound. Stop operation immediately to avoid damage to the engine. Check the water level in the cooling water recovery tank and troubleshoot the cooling system.



## Fuel Filter (Water Separator)

When the water level inside the water separator becomes too high, the sensor will send a signal to the indicator causing it to light. Drain the water separator. If operation is continued without draining the water separator, fuel feed to the engine is restricted and may cause damage to the engine or fuel injection pump.

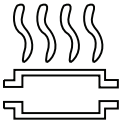

## Exhaust (Cooling Seawater Flow) Restriction

When the amount of cooling seawater being discharged is too low, the sensor will activate the warning indicator. Stop operation immediately to avoid damage to the engine. Check the seawater cooling system for restriction or damage.



## Gear Oil Level (6LPA-STZP2 Only)

When the amount of gear oil falls below normal, the sensor will send a signal to the indicator causing it to light and the alarm to sound. Stop engine immediately to avoid damage to the gear device. Check the oil level in the gear and troubleshoot the gear system.

## Alarms

Check that indicators and alarms are working normally when the key is turned to ON.

Key Switch		OFF ⇒ ON	START ⇒ ON
Engine		Before starting	Running
Alarm		ON	OFF
Indicators	Battery Low Charge Indicator	ON	OFF
	Fresh Water (Coolant) High Temperature Indicator	OFF	OFF
	Engine (Lube) Oil Low Pressure Indicator	ON	OFF
	Fresh Water (Coolant) Level Indicator	OFF	OFF
	Fuel Filter (Water Separator) Indicator	OFF	OFF
	Exhaust (Cooling Seawater Flow) Restriction Indicator	ON	OFF
	Gear Oil Level (6LPA-STZP2 Only)	OFF	OFF

## Key (Starter) Switch

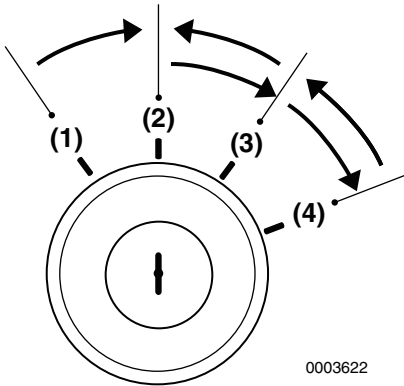

**Figure 7**

The GLOW position (**Figure 7, (1)**) is the start aid position. Electric current to the air heater (if equipped) is turned on.

The START position (**Figure 7, (4)**) allows current to the starting motor. When starting the engine, move the key to the START position and release. The key will automatically move to the ON position.

### NOTICE

NEVER hold the key in the START position for longer than 15 seconds or the starter motor will overheat.

When the key is in the OFF position (**Figure 7, (2)**) the electric current is off. The key can be inserted or removed in this position.

The ON position (**Figure 7, (3)**) allows electrical current to the controls and equipment and allows the engine to keep running. To stop the engine, keep the key switch in the ON position and push the engine stop button. After stopping the engine, turn key to OFF position.

## Engine Stop Button

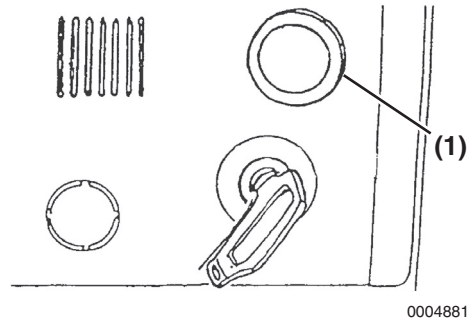

**Figure 8**

Push and hold the stop button (**Figure 8, (1)**) on the instrument panel to stop the engine. When the stop button is pushed, the solenoid valve on the fuel injection pumps stops the fuel supply to the engine.

Press and hold the engine stop button until the engine has come to a complete stop.

### NOTICE

Releasing the engine stop button before the engine has stopped rotating will cause the engine to continue to run.

## Remote Control (Throttle) Handle

The engine is controlled by the remote control handle located in the cockpit. The speed control lever on the engine and clutch lever on the marine drive are connected by remote control cables. There are various models of remote control handles available. When using a model other than shown below, consult the manufacturer's documentation for more information.

# PRODUCT OVERVIEW

## Morse Remote Control Handle (Optional)

This is a single-lever remote control handle connected by a remote cable. It operates the clutch to NEUTRAL, FORWARD and REVERSE and controls the engine speed.

### MT-3 Top Mount

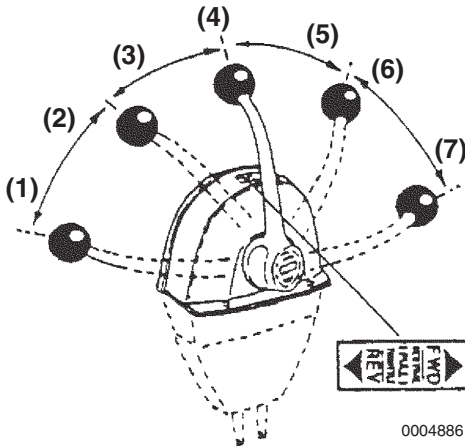

Figure 9

- 1 – Reverse High Speed
- 2 – Reverse Low Speed
- 3 – Reverse
- 4 – Neutral
- 5 – Forward
- 6 – Forward Low Speed
- 7 – Forward High Speed

### MV Side Mount

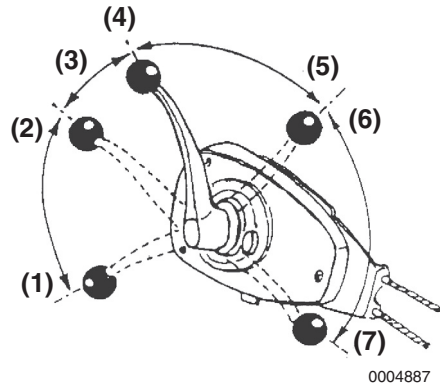

Figure 10

- 1 – Forward High Speed
- 2 – Forward Low Speed
- 3 – Forward
- 4 – Neutral
- 5 – Reverse
- 6 – Reverse Low Speed
- 7 – Reverse High Speed

The operation labels on the handle are:

- FWD - Forward
- NEU - Neutral (Clutch Disengaged)
- Throttle - Position to reduce engine speed
- REV - Reverse

### Starting and Stopping

Put the handle in NEUTRAL. This puts the clutch in the disengaged position and the engine at a low speed.

### Forward

Move the handle from NEUTRAL to FWD (forward). This engages the clutch in forward and simultaneously increases the engine speed. Pushing the handle further in the same direction increases engine speed to full speed.

**Reverse**

Move the handle from NEUTRAL to REV (reverse). This engages the clutch in reverse and simultaneously increases the engine speed. Pushing the handle further in the same direction increases engine speed to full speed.

**Free Throttle Operation**

When the boat is stopped (clutch is in NEUTRAL) the idling speed of the engine can be increased in the following manner:

1. Ensure the handle is in NEUTRAL.
2. Disengage the clutch:

**MT-3**

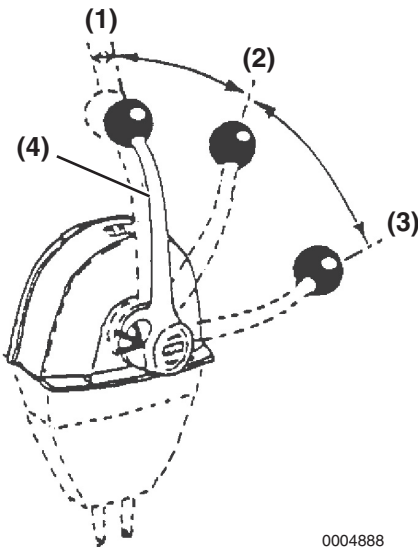

0004888

**Figure 11**

- 1 – Neutral
- 2 – Low Speed
- 3 – High Speed
- 4 – Remote Control (Throttle) Handle

**MV**

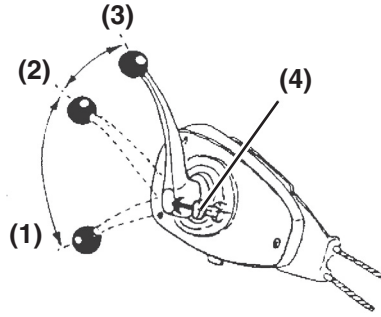

0004889

**Figure 12**

- 1 – High Speed
- 2 – Low Speed
- 3 – Neutral
- 4 – Free Throttle Button

3. • **MT-3:** Pull the throttle handle (**Figure 11, (4)**) all the way out.
- **MV:** Pull out the free throttle button (**Figure 12, (4)**), located next to the handle.

When the handle or button is pulled out, move the handle to either FORWARD or REVERSE to increase the idling speed.

**Returning to Normal Operation**

- **MT-3:** Move the throttle handle to NEUTRAL (**Figure 11, (1)**). The lever will automatically return to the normal position.
- **MV:** Move throttle handle to NEUTRAL (**Figure 12, (3)**). Push the free throttle button in.

**Page Intentionally Left Blank**

# BEFORE YOU OPERATE

---

## INTRODUCTION

This section of the *Operation Manual* describes the diesel fuel, engine oil and engine coolant specifications and how to replenish them.

## SAFETY PRECAUTIONS

Before performing any operations within this section, review the *Safety* section on page 3.

# BEFORE YOU OPERATE

## DIESEL FUEL

### Diesel Fuel Specifications

#### WARNING

**Fire and Explosion Hazard.**  
**Diesel fuel is flammable and explosive under certain conditions.**

Only use diesel fuels recommended by Yanmar for the best engine performance, to prevent engine damage. Only use clean diesel fuel.

Diesel fuel should comply with the following specifications. The table lists several worldwide specifications for diesel fuels.

DIESEL FUEL SPECIFICATION	LOCATION
No. 2-D, No. 1-D, ASTM D6751, D7467,	USA
EN590-2009, EN14214	European Union
ISO 8217 DMX	International
BS 2869-A1 or A2	United Kingdom
JIS K2204 Grade No. 2	Japan

### Biodiesel Fuels

Yanmar approves the use of biodiesel fuels that do not exceed a blend of 7% non-mineral oil based fuel with 93% standard diesel fuel. Such biodiesel fuels are known in the marketplace as B7 biodiesel fuels. B7 biodiesel fuel can reduce particulate matter and the emission of “greenhouse” gases compared to standard diesel fuel.

If the B7 biodiesel fuel used does not meet the approved specifications, it will cause abnormal wear of injectors, reduce the life of the engine and it may affect the warranty coverage of your engine.

### ***B7 diesel fuels must meet certain specifications.***

The biodiesel fuels must meet the minimum specifications for the country in which they are used:

- In Europe, biodiesel fuels must comply with the European Standard EN590-2009, EN14214.
- In the United States, biodiesel fuels must comply with the American Standard ASTM D-6751, D7467.

Biodiesel should be purchased only from recognized and authorized diesel fuel suppliers.

### ***Precautions and concerns regarding the use of biofuels:***

- Biodiesel fuels have a higher content of methyl-esters, which may deteriorate certain metal, rubber and plastic components of the fuel system. The customer and / or boat builder are responsible to verify the usage of biodiesel compatible components on the vessel fuel supply and return systems.
- Free water in biodiesel may result in plugging of fuel filters and increased bacterial growth.
- High viscosity at low temperatures may result in fuel delivery problems, injection pump seizures and poor injection nozzle spray atomization.
- Biodiesel may have adverse effects on some elastomers (seal materials) and may result in fuel leakage and dilution of the engine lubricating oil.



- Even biodiesel fuels that comply with a suitable standard as delivered will require additional care and attention to maintain the quality of the fuel in the equipment or other fuel tanks. It is important to maintain a supply of clean, fresh fuel. Regular flushing of the fuel system, and / or fuel storage containers, may be necessary.
- The use of biodiesel fuels that do not comply with the standards as agreed to by the diesel engine manufacturers and the diesel fuel injection equipment manufacturers, or biodiesel fuels that have degraded as per the precautions and concerns above, may affect the warranty coverage of your engine.

### Additional Technical Fuel Requirements

- The fuel cetane number should be 45 or higher.
- The sulfur content must not exceed 0.5% by volume. Less than 0.05% is preferred.
- NEVER mix kerosene, used engine oil or residual fuels with the diesel fuel.
- Water and sediment in the fuel should not exceed 0.05% by volume.
- Keep the fuel tank and fuel-handling equipment clean at all times.
- Ash content not to exceed 0.01% by volume.
- Carbon residue content not to exceed 0.35% by volume. Less than 0.1% is preferred.
- Total aromatics content should not exceed 35% by volume. Less than 30% is preferred.
- PAH (poly cyclic aromatic hydrocarbons) content should be below 10% by volume.
- Do not use Beside.
- Do not use kerosene or residual fuels.

## Handling of Diesel Fuel

### WARNING

**Fire and Explosion Hazard.**  
**Only fill the fuel tank with diesel fuel.** Filling the fuel tank with gasoline may result in a fire and will damage the engine. **NEVER** refuel with the engine running. **Wipe up all spills immediately.** **Keep sparks, open flames or any other form of ignition (match, cigarette, static electric source) well away when refueling.**

**Fire and Explosion Hazard.**  
**ALWAYS** put the diesel fuel container on the ground when transferring the diesel fuel from the pump to the container. **Hold the hose nozzle firmly against the side of the container while filling it.** This prevents static electricity buildup which could cause sparks and ignite fuel vapors.

1. Water and dust in the fuel may cause engine failure. When fuel is stored, be sure that the inside of the storage container is clean and dry, and that the fuel is stored away from dirt or rain.

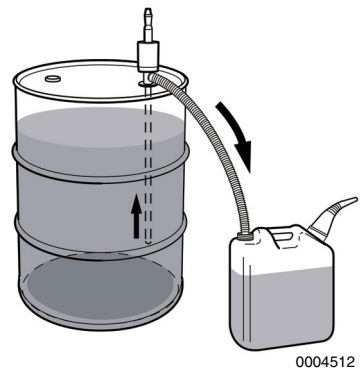

**Figure 1**

## BEFORE YOU OPERATE

2. Keep the fuel container stationary for several hours to allow any dirt or water to settle to the bottom of the container. Use a pump to extract the clear, filtered fuel from the top of the container.

### Fuel Tank (Optional)

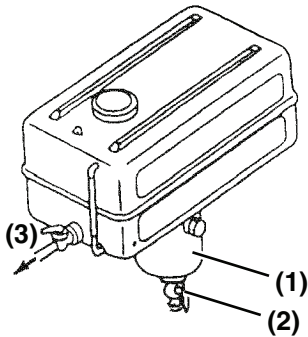

Figure 2

0004898

- 1 – Sediment Bowl
- 2 – Drain Cock
- 3 – Fuel Line to Engine

Install a drain cock (**Figure 2, (2)**) at the bottom of the fuel tank to remove water and contaminants from the sediment bowl (**Figure 2, (1)**).

The fuel outlet should be positioned 20 to 30 mm (0.75 to 1.125 in.) above the bottom of the tank so that only clean fuel is distributed to the engine.

### Fuel System

Install the fuel line from the fuel tank to the fuel injection pump as shown in **Figure 3**.

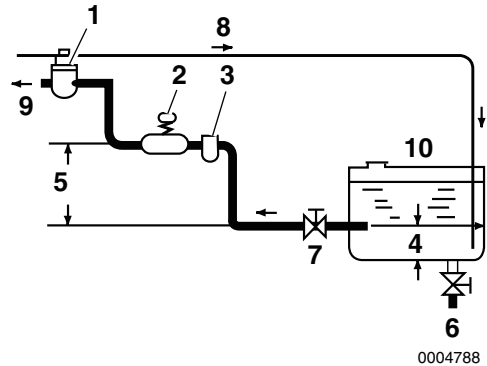

Figure 3

- 1 – Fuel Filter
- 2 – Fuel Feed Pump (Priming Lever)
- 3 – Fuel / Water Separator (Optional)
- 4 – Approximately 20 - 30 mm (0.75 - 1.125 in.)
- 5 – Within 500 mm (20 in.)
- 6 – Drain Cock
- 7 – Fuel Cock
- 8 – Fuel Return Line
- 9 – To Fuel Injection Pump
- 10 – Fuel Tank

### Filling the Fuel Tank

Before filling fuel tank for the first time:

#### **⚠ WARNING**

**Fire and Explosion Hazard.**  
**NEVER** refuel with the engine running.

Rinse fuel tank with kerosene or diesel fuel. Dispose of waste properly.

**Filling the fuel tank:****⚠ WARNING**

**Fire and Explosion Hazard.**  
Operate bilge ventilation (blowers) for a minimum of 5 minutes to purge fumes from engine compartment after refueling. Never operate bilge blower while refueling. Doing so can pump explosive fumes into the engine compartment and result in an explosion.

1. Clean the area around the fuel cap.
2. Remove the fuel cap from the fuel tank.
3. Fill the tank with clean fuel free of oil and dirt.

**⚠ WARNING**

**Fire and Explosion Hazard.**  
Hold the hose nozzle firmly against the filler port while filling. This prevents static electricity buildup which could cause sparks and ignite fuel vapors.

4. Stop fueling when the gauge shows the fuel tank is full.

**⚠ WARNING**

**Fire and Explosion Hazard.**  
**NEVER overfill the fuel tank.**

5. Replace the fuel cap and hand-tighten. Over-tightening the fuel cap will damage it.

**Bleeding the Fuel System**

Bleeding must be done if any fuel system maintenance has been performed (replacement of fuel filter, etc.) or if the engine does not start after several attempts.

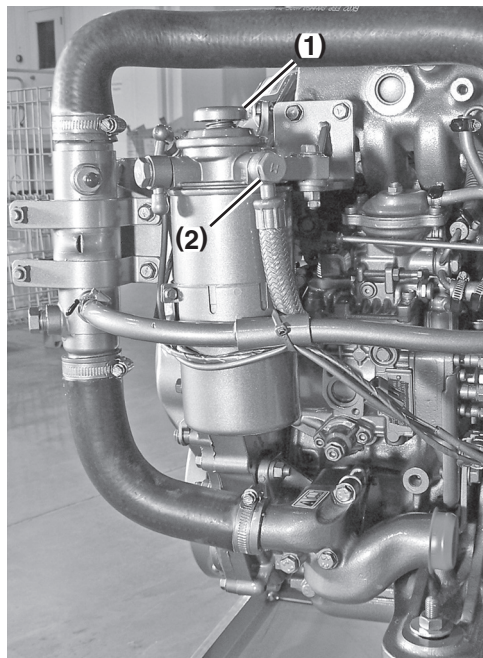

0004908

**Figure 4**

- 1 – Priming Pump**  
**2 – Air Bleed Screw**

1. Check the fuel level in the fuel tank. Refill if necessary.
2. Open the fuel cock of the fuel tank.

**⚠ WARNING**

**Exposure Hazard.**

**Always wear safety glasses when bleeding the fuel system.**

## BEFORE YOU OPERATE

---

- Loosen the air bleed screw (**Figure 4, (2)**) two to three turns.
- Push up and down on the priming pump (**Figure 4, (1)**) to release air out of the air bleed screw.
- Continue pumping until a solid stream of fuel with no air bubbles begins to flow.
- Tighten the air bleed screw.

### NOTICE

NEVER use an engine starting aid such as ether. Engine damage will result.

---

## ENGINE OIL

### Engine Oil Specifications

Using engine oil that does not meet or exceed the following guidelines or specifications may cause seizure of parts, abnormal wear and shorten engine life.

### Service Categories

Use an engine oil that meets or exceeds the following guidelines and classifications:

- API Service Categories: CD or higher
- SAE Viscosity:  
10W30, 15W40. Engine oil 10W30 and 15W40 can be used throughout the year.

### NOTICE

- Be sure the engine oil, engine oil storage containers and engine oil filling equipment are free of sediment or water.
  - Change the engine oil after the first 50 hours of operation and then at every 250 hours thereafter.
  - Select the oil viscosity based on the ambient temperature where the engine is being operated. See the SAE Service Grade Viscosity Chart (**Figure 5**).
  - Yanmar does not recommend the use of engine oil “additives.”
-

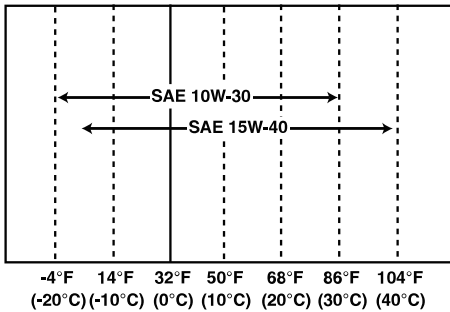

0000005

Figure 5

## Handling Engine Oil

1. When handling and storing engine oil, be careful not to allow dust and water to contaminate the oil. Clean around the filler port before filling.
2. Do not mix oils of different types or brands. Mixing may cause the chemical characteristics of the oil to change and lubricating performance to decrease, reducing the engine's life.
3. Engine oil should be replaced at the specified intervals, regardless if the engine has been operated.

## Engine Oil Viscosity

SAE 10W30 or SAE 15W40 are the recommended oil viscosities.

### NOTICE

If you intend to operate your equipment at temperatures outside the limits shown, you must consult your authorized Yanmar Marine dealer or distributor for special lubricants or starting aids.

## Checking the Engine Oil

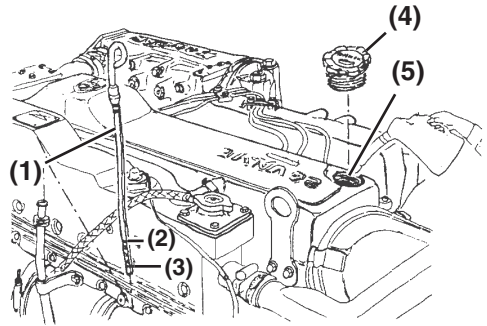

0004902

Figure 6

1. Make sure the engine is level.
2. Remove dipstick (**Figure 6, (2)**) and wipe with clean cloth.
3. Fully reinsert dipstick.
4. Remove dipstick. The oil level should be between upper (**Figure 6, (2)**) and lower (**Figure 6, (3)**) lines on the dipstick.
5. Add oil if necessary. *See Adding Engine Oil on page 31.*
6. Fully reinsert dipstick.

## Adding Engine Oil

1. Remove the oil filler port cap from filler port (**Figure 6, (5)**) and fill with engine oil.

### NOTICE

Prevent dirt and debris from contaminating engine oil. Carefully clean the dipstick and the surrounding area before you remove the cap.

2. Fill with engine oil to the upper limit (**Figure 6, (2)**) on the dipstick (**Figure 6, (1)**).

### NOTICE

NEVER overfill the engine with engine oil.

---

3. Insert the dipstick fully to check the level.

### NOTICE

ALWAYS keep the oil level between upper and lower lines on the oil cap / dipstick.

---

4. Hand-tighten the filler port cap securely.

## MARINE DRIVE OIL

Note: Refer to the marine gear manufacturer's operation manual for the marine gear oil specifications. Refer to the manufacturer's operation manual for marine gear or stern drive oil specifications.

### MerCruiser® Bravo Stern Drive Oil Specifications

Use marine gear oil that meets or exceeds the following guidelines and classifications:

#### Drive Oil

- Quick Silver® <sup>1</sup> High Performance Gear Lube

#### Power Steering Oil (6LPA-STZP2 Only)

- Quick Silver® Power Trim and Steering Fluid or Dexlone-II.

#### Power Trim Oil

- Quick Silver® Power Trim and Steering Fluid or SAE 10W-30 or 10W-40 Engine Oil.

### Checking and Adding Marine Drive Oil

Note: Refer to the manufacturer's operation manual for the proper procedure to check and fill the marine drive oil.

---

<sup>1</sup>Quick Silver is a registered trademark of Brunswick @ Corporation.

## Checking and Adding Power Steering Oil (6LPA-STZP2 Models)

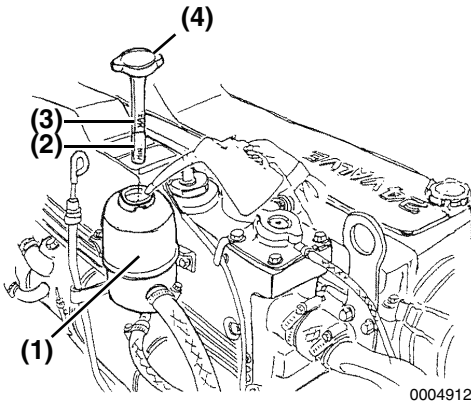

**Figure 7**

1. Remove the filler cap / dipstick (**Figure 7, (3) (4)**) from the power steering oil service tank (**Figure 7, (1)**) and wipe with a clean cloth.
2. Fully reinsert dipstick.
3. Remove dipstick. The oil level should be between upper (**Figure 7, (3)**) and lower (**Figure 7, (2)**) lines on the dipstick.
4. Fill with oil to the upper limit on the dipstick. See *MerCruiser® Bravo Stern Drive Oil Specifications* on page 32.

### NOTICE

NEVER overfill the power steering system with oil.

5. Fully reinsert dipstick and tighten.

## ENGINE COOLANT

### Engine Coolant Specifications

Note: In the U.S., LLC is required for the warranty to be valid.

- Texaco Long Life Coolant (LLC), both standard and premixed, product code 7997 and 7998
- Havoline Extended Life Antifreeze / Coolant, product code 7994

Following the manufacturer's recommendations, use a proper LLC which will not have any adverse effects on the materials (cast iron, aluminum, copper, etc.) of the engine's cooling system.

ALWAYS use the mixing ratios specified by the antifreeze manufacturer for the temperature range.

## BEFORE YOU OPERATE

### Coolant (Closed Cooling System)

#### NOTICE

ALWAYS add LLC to soft water especially when operating in cold weather. NEVER use hard water. Water should be clean and free from sludge or particles. Without LLC, cooling performance will decrease due to scale and rust in the coolant system. Water alone may freeze and form ice; it expands approximately 9% in volume. Use the proper amount of coolant concentrate for the ambient temperature as specified by the LLC manufacturer. LLC concentration should be a minimum of 30% to a maximum of 60%. Too much LLC will decrease the cooling efficiency. Excessive use of antifreeze also lowers the cooling efficiency of the engine. NEVER mix different types or brands of LLC, as a harmful sludge may form. Mixing different brands of antifreeze may cause chemical reactions, and may make the antifreeze useless or cause engine problems.

---

### Checking and Adding Coolant

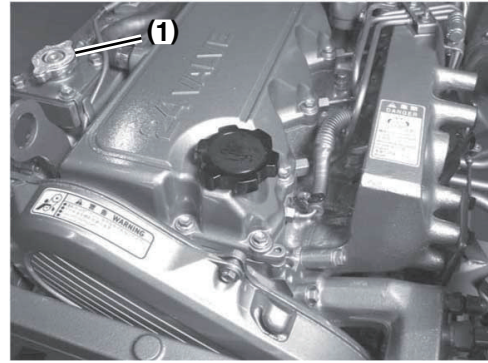

Figure 8

1. Ensure all drain cocks are closed.
2. Loosen the filler cap of the coolant tank to relieve the pressure, then remove the filler cap (**Figure 8, (1)**).

#### ⚠ WARNING

##### **Burn Hazard.**

**NEVER** remove the coolant filler cap if the engine is hot. Steam and hot engine coolant will spray out and seriously burn you. Allow the engine to cool down before you attempt to remove the cap.

---

3. Pour coolant slowly into the coolant tank to avoid air bubbles. Fill until coolant overflows from the filler port.

#### NOTICE

NEVER pour cold coolant into a hot engine.

---

4. Align filler cap tabs with filler port notches and tighten filler cap firmly.



**NOTICE**

ALWAYS tighten reservoir cap securely after checking reservoir. Steam can spray out during engine operation if the cap is loose..

Note: The coolant level rises in the reservoir during operation. After stopping the engine, the coolant will cool down and the extra coolant will return to reservoir.

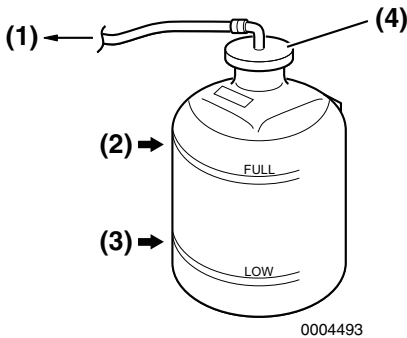

**Figure 9**

5. Check the coolant level in the reservoir. The level should be at the FULL mark (**Figure 9, (2)**). Add coolant if necessary.

**NOTICE**

NEVER pour cold coolant into a hot engine.

6. Remove reservoir cap (**Figure 9, (4)**) to add coolant if necessary. Do not add water.
7. Replace filler cap and tighten it firmly. Failure to do so will cause water leakage.

**Reservoir Capacity**

0.8 L (0.85 qt)

8. Check the rubber hose(**Figure 9, (1)**) connecting the reservoir to the coolant tank / heat exchanger. Replace if damaged.

Note: If the coolant runs low too often or the coolant level in the coolant tank drops without any change in the level in the reservoir, there may be water or air leaks in the cooling system. See your authorized Yanmar dealer or distributor.

## BEFORE YOU OPERATE

### CRANKING THE ENGINE

#### NOTICE

When the engine has not been used for a long period of time, engine oil will not be distributed to all of the operating parts. Using the engine in this condition will lead to seizure. After a long period of no use, distribute engine oil to each part by cranking. Perform in accordance with the following procedures before beginning operation.

1. Open the seacock.
2. Open the fuel cock.
3. Put the remote control shift lever in the NEUTRAL See *Starting the Engine on page 39*.
4. Turn on the battery switch (if equipped).

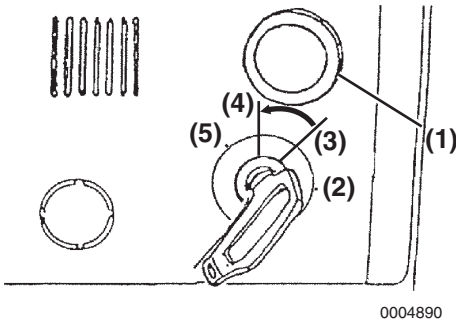

Figure 10

5. Turn key to ON (**Figure 10, (3)**). It is normal for the alarm to sound and the warning indicators to light during cranking.

Note: If the engine has not been operated for a long period of time, check that the key can be moved from START to ON positions smoothly.

6. While pushing the STOP button (**Figure 10, (1)**), turn the key to the START position (**Figure 10, (2)**).

#### NOTICE

NEVER hold the key in the START position for longer than 15 seconds or the starter motor will overheat.

7. When the key is in the START position, the engine will begin cranking. Continue cranking for about 5 seconds and listen for abnormal noise during that time.

Note: If the STOP button is released during the cranking procedure, the engine will start. Do not start the engine in this mode.

8. Move key to OFF position (**Figure 10, (4)**). The engine will stop cranking.

#### WARNING



Never touch or allow your clothes to touch the moving parts of the engine during operation. If a part of your body or clothing is caught in the front drive shaft, V-belt, propeller shaft, etc. serious injury may result. Check to see that no tools, pieces of cloth, etc. are left on or around the engine.

# ENGINE OPERATION

---

## INTRODUCTION

This section of the *Operation Manual* describes the diesel fuel, engine oil and engine coolant specifications and how to replenish them. It also describes the daily engine checkout.

## SAFETY PRECAUTIONS

Before performing any operations within this section, review the *Safety* section on page 3.

## WARNING

### Fire and Explosion Hazard



**NEVER** jump-start the engine. Sparks caused by shorting the battery to the starter terminals may cause a fire or explosion. **ONLY** use the start switch on the instrument panel to start the engine.

### Sudden Movement Hazard

Be sure the boat is in open water away from other boats, docks or other obstructions before increasing engine speed. Avoid unexpected equipment movement. Shift the marine gear into the **NEUTRAL** position any time the engine is at idle.

To prevent accidental equipment movement, **NEVER** start the engine in gear.

### Sever Hazard



Keep children and pets away while the engine is operating.

## NOTICE

If any indicator illuminates during engine operation, stop the engine immediately. Determine the cause and repair the problem before you continue to operate the engine.

If the alarm indicator with audible alarm fails to display and go out about 3 seconds after the ignition switch is turned on, see your authorized Yanmar Marine dealer or distributor for service before operating the engine

If the vessel is equipped with a water lift (water lock) muffler, excessive cranking could cause seawater to enter the cylinders and damage the engine. If the engine does not start after cranking for 10 seconds, close the thru-hull water intake valve to avoid filling the muffler with water. Crank for 10 seconds at a time until the engine starts. When the engine does start, stop the engine immediately and turn off the switch.

Be sure to re-open the seacock and restart the engine. Operate the engine normally.

Observe the following environmental operating conditions to maintain engine performance and avoid premature engine wear:

- Avoid operating in extremely dusty conditions.
- Avoid operating in the presence of chemical gases or fumes.
- **NEVER** run the engine if the ambient temperature is above +40°C (+104°F) or below -16°C (+5°F).
- If the ambient temperature exceeds +40°C (+104°F), the engine may overheat and cause the engine oil to break down.
- If the ambient temperature is below -16°C (+5°F), rubber components such as gaskets and seals will harden causing premature engine wear and damage.

**NOTICE**

- Contact your authorized Yanmar Marine engine dealer or distributor if the engine will be operated outside of this standard temperature range.

NEVER engage the starter motor while the engine is running. Damage to the starter motor pinion and / or ring gear will result.

**STARTING THE ENGINE**

1. Open the seacock (if equipped).
2. Open the fuel cock.
3. Put the remote control handle in NEUTRAL.

Note: Safety equipment should make it impossible to start the engine in any other position than NEUTRAL.

4. Turn the battery master switch (if equipped) to ON.

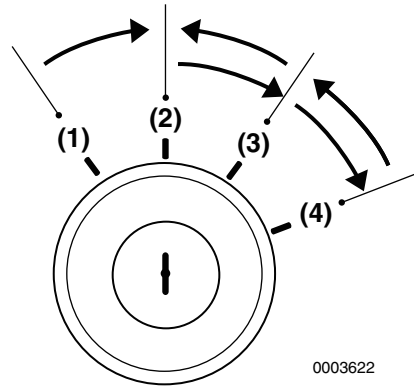

0003622

**Figure 1**

5. Turn key switch to ON (**Figure 1, (3)**). Ensure that the instrument panel indicators light and the alarm sounds. This indicates that indicators and alarm are working correctly.

Note: The coolant high temperature alarm indicator does not come on during start-up.

6. Turn the key switch to START (**Figure 1, (4)**). Release the key switch when the engine has started.

### **NOTICE**

NEVER hold the key in the START position for longer than 15 seconds or the starter motor will overheat.

---

7. The alarm should stop and the indicators should go out.

### **NOTICE**

If any indicator fails to illuminate when the key switch is in the ON position, see your authorized Yanmar Marine dealer or distributor for service before operating the engine.

---

Note: When the engine has not been used for a long period of time, check that the key can move from the START position to the ON position smoothly.

### **If the Engine Fails to Start**

Before turning the key switch again, be sure to confirm that the engine has stopped completely. If an attempt to restart is made while the engine is running, the pinion gear of the starter motor will be damaged.

### **NOTICE**

NEVER hold for longer than 15 seconds or the starter motor will overheat.

---

NEVER attempt to restart the engine if the engine has not stopped completely. Pinion gear and starter motor damage will occur.

---

Note: Hold the key switch for a maximum of 15 seconds. If the engine does not start the first time, wait for about 15 seconds before trying again.

### **NOTICE**

If the vessel is equipped with a water lift (water lock) muffler, excessive cranking could cause seawater to enter the cylinders and damage the engine. If the engine does not start after cranking for 15 seconds, close the thru-hull water intake valve to avoid filling the muffler with water. Crank for 10 seconds at a time until the engine starts. When the engine does start, stop the engine immediately and turn off the power switch. Be sure to re-open the seacock and restart the engine. Operate the engine normally.

---

## Air Bleeding the Fuel System After Starting Failure

If the engine does not start after several attempts, there may be air in the fuel system. If air is in the fuel system, fuel cannot reach the fuel injection pump. Bleed the air out of the system. See *Priming Pump* on page 29.

## Starting at Low Temperatures

Comply with local environmental requirements. Use engine heaters to avoid starting problems and white smoke. Do not use starting aids.

### NOTICE

NEVER use an engine starting aid such as ether. Engine damage will result.

To limit white smoke, run the engine at low speed and under moderate load until the engine reaches normal operating temperature. A light load on a cold engine provides better combustion and faster engine warm-up than no load.

Avoid running the engine at idling speed any longer than necessary.

## Starting with Air Heater (If Equipped)

1. Open the seacock (if equipped).
2. Open the fuel tank cock.
3. Put remote control handle in NEUTRAL.
4. Turn the battery switch on (if equipped)..

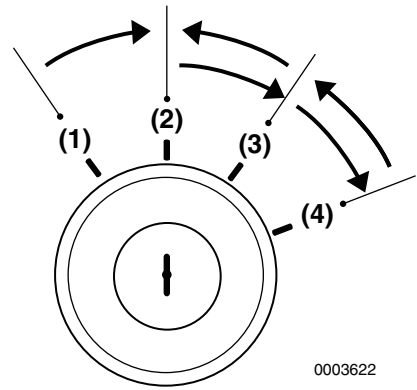

0003622

Figure 2

5. Turn key switch to GLOW (**Figure 2, (1)**) for 15 seconds.

### NOTICE

NEVER run the air heater (GLOW position) for more than 20 seconds at a time or engine damage will result.

6. Turn key switch to ON (**Figure 2, (3)**). Ensure that the instrument panel indicators light and the alarm sounds. This shows that indicators and alarm are working correctly.

Note: The coolant high temperature alarm indicator does not come on during start-up.

7. Turn key switch to START (**Figure 2, (4)**). Release the key switch when the engine has started. The alarm should stop and the indicators should go out.

### NOTICE

NEVER hold the key in the START position for longer than 15 seconds or the starter motor will overheat.

## After the Engine has Started

1. After the engine has started, ensure the remote control handle is in NEUTRAL.

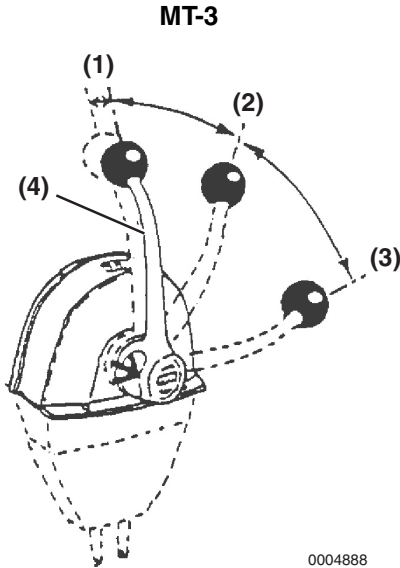

**Figure 3**

- 1 – Neutral
- 2 – Low Speed
- 3 – High Speed
- 4 – Throttle Handle

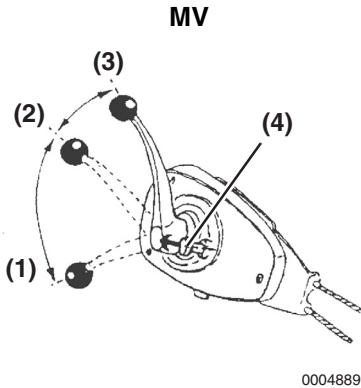

**Figure 4**

- 1 – High Speed
- 2 – Low Speed
- 3 – Neutral
- 4 – Free Throttle Button

2. **MT-3:** Pull out the handle lever (**Figure 3, (4)**) and adjust the speed to no more than 1500 rpm and run the engine at low speed with no load.
3. **MV:** Pull out the free throttle button (**Figure 4, (4)**) and adjust the speed to no more than 1500 rpm and run the engine at low speed with no load.
4. Allow engine to run for approximately 5 minutes.

Check the following items at a low engine speed:

- 1- Check that the gauges, indicators and alarm are normal.
- Normal coolant operating temperature is approximately 70° to 90°C (158° to 194°F).
- Normal oil pressure at 3000 min<sup>-1</sup> is 0.34 to 0.54 MPa (48 to 78 psi).
- 1- Check for water, fuel or oil leakage from the engine.
- 2- Check that the smoke color, engine vibration and sound are normal.
- 3- When there are no problems, keep the engine at low speed with the boat still stopped to distribute engine oil to all parts of the engine.
- 4- Check that sufficient cooling water is discharged from the seawater outlet. Operation with inadequate seawater discharge will damage the impeller of the seawater pump. If seawater discharge is too low, stop the engine immediately. Identify the cause and repair.

## NOTICE

The engine will seize if it is operated when seawater discharge is too small or if load is applied without any warming up operation.



For troubleshooting assistance, see *Troubleshooting After Starting on page 69* or *Troubleshooting Chart on page 71* . If necessary, see your authorized Yanmar dealer or distributor.

## REMOTE CONTROL HANDLE OPERATION

### Acceleration and Deceleration

#### MT-3 Top Mount

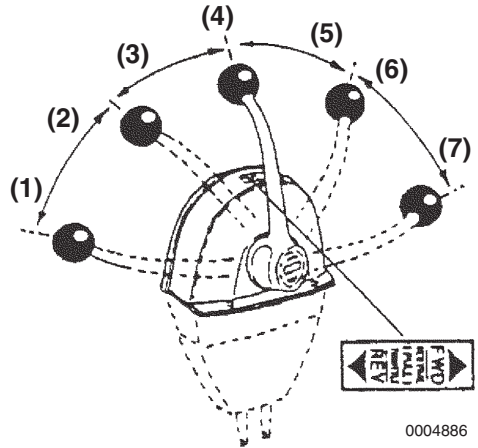

Figure 5

- 1 – Reverse High Speed
- 2 – Reverse Low Speed
- 3 – Reverse
- 4 – Neutral
- 5 – Forward
- 6 – Forward Low Speed
- 7 – Forward High Speed

#### MV Side Mount

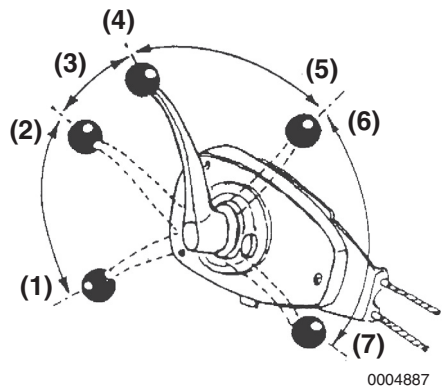

Figure 6

## ENGINE OPERATION

---

- 1 – Forward High Speed
- 2 – Forward Low Speed
- 3 – Forward
- 4 – Neutral
- 5 – Reverse
- 6 – Reverse Low Speed
- 7 – Reverse High Speed

Note: Direction of travel will vary depending on installation location.

Use the throttle handle to control acceleration and deceleration. Move the handle slowly and smoothly.

### Shifting the Engine

#### **WARNING**

**Sudden Movement Hazard.**  
The boat will start to move when the marine drive is engaged:

- Ensure the boat is clear of all obstacles forward and aft.
- Quickly shift to the **FORWARD** position then back to the **NEUTRAL** position.
- Observe whether the boat moves in the direction you expect.

#### **NOTICE**

Shifting the marine drive while operating at high speed or not pushing the handle fully into position (partial engagement) will result in damage to marine drive parts and abnormal wear.

---

1. Before using the marine drive, be sure to move the throttle handle to a low idle position (less than 1000 min<sup>-1</sup>). Move the throttle handle slowly to a higher speed position after completing marine drive engagement.

2. When moving the handle between **FORWARD (Figure 6, (1 to 2))** and **REVERSE (Figure 6, (6 to 7))**, bring the handle to **NEUTRAL (Figure 6, (4))** and pause before slowly shifting to the desired position. **NEVER** shift abruptly from **FORWARD** to **REVERSE** or vice versa.

#### **NOTICE**

- **NEVER** shift the marine gear at high engine speed. During normal operation, the marine gear should only be shifted with the engine at idle.
  - When sailing, set the remote control handle in **NEUTRAL**. Not doing so **WILL** introduce slippage or any damage and void your warranty.
- 

### Morse Remote Control Handle (Optional)

- Move the handle to the **NEUTRAL** (middle) position to stop the boat. The engine will idle at low speed.
- Move the handle to the **FORWARD** position to go forward. When the clutch is engaged in forward, the speed will decrease.
- Move the handle to the **REVERSE** position to go in reverse. When the clutch is engaged in reverse, the speed will decrease.

## CAUTIONS DURING OPERATION

### NOTICE

Engine trouble can arise if the engine is operated for a long time under overloaded conditions with the control handle in the full throttle position (maximum engine speed position), exceeding the continuous rated output engine speed. Operate the engine at about 100 min<sup>-1</sup> lower than the full throttle engine speed.

---

Note: If the engine is in the first 50 hours of operation, see *New Engine Break-In on page 10*.

Always be on the lookout for problems during engine operation.

Pay particular attention to the following:

- Is sufficient seawater being discharged from the exhaust and seawater outlet pipe?

If the discharge is small, stop the engine immediately; identify the cause and repair.

- Is the smoke color normal?

The continuous emission of black exhaust smoke indicates engine overloading. This shortens the engines life and should be avoided.

- Are there abnormal vibrations or noise?

### NOTICE

Excessive vibration may cause damage to the engine, marine gear, hull and onboard equipment. In addition, it causes able passenger and crew discomfort.

---

Depending on the hull structure, engine and hull resonance may suddenly become great at a certain engine speed range, causing heavy vibrations. Avoid operation in this speed range. If you hear any abnormal sounds, stop the engine and inspect.

- Alarm buzzer sounds during operation.

### NOTICE

If any alarm indicator with audible alarm sound appears on the display during engine operation, stop the engine immediately. Determine the cause and repair the problem before you continue to operate the engine.

- 
- Is there water, oil or fuel leakage, or are there any loose bolts?

Check the engine room periodically for any problems.

- Is there sufficient diesel fuel in the diesel fuel tank?

Replenish diesel fuel before leaving the dock to avoid running out of fuel during operation.

- When operating the engine at low speed for long periods of time, race the engine once every 2 hours.

## NOTICE

Racing the engine: With the gear in NEUTRAL, accelerate from the low-speed position to the high-speed position and repeat this process about five times. This is done to clean out carbon from the cylinders and the fuel injection valve. Neglecting to race the engine will result in poor smoke color and reduce engine performance.

- If possible, periodically operate the engine at near maximum engine speed while underway. This will generate higher exhaust temperatures, which will help clean out hard carbon deposits, maintaining engine performance and prolonging the life of the engine.

## NOTICE

NEVER turn off the battery switch (if equipped) or short the battery cables during operation. Damage to the electric system will result.

## SHUTTING DOWN THE ENGINE

### Normal Shutdown

1. Reduce engine speed to low idle and put remote control handle in NEUTRAL.
2. Accelerate from low speed to high speed and repeat five times. This will clean out the carbon from the cylinders and the fuel injection nozzles.
3. Allow engine to run at low speed (approximately  $1000 \text{ min}^{-1}$ ) without load for 5 minutes.

## NOTICE

For maximum engine life, Yanmar recommends that when shutting the engine down, you allow the engine to idle, without load, for 5 minutes. This will allow the engine components that operate at high temperatures, such as the turbocharger and exhaust system, to cool slightly before the engine itself is shut down.

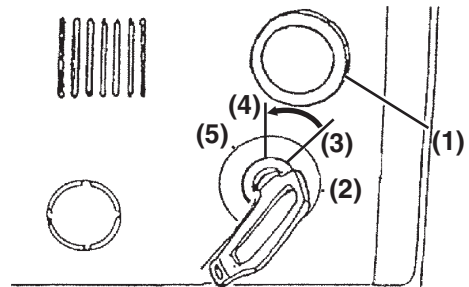

0004890

**Figure 7**

4. With the key in the ON position, push and hold the STOP button (**Figure 7, (1)**). After the engine has stopped, turn the key switch to OFF.

5. Remove the key and cover the key switch with the moisture cap.

### NOTICE

Continue to hold the stop button in until the engine is completely stopped. If the button is released before the engine has completely stopped, it may restart. *If the engine does not shut off when the engine stop button is pushed, close the fuel cock on the fuel tank.*

6. Turn off the battery switch (if equipped).
7. Close the fuel cock.
8. Close the seacock (if equipped).

### NOTICE

- Be sure to close the seacock. Neglecting to close the seacock could allow water to leak into the boat and may cause it to sink.
- If seawater is left inside the engine, it may freeze and damage parts of the cooling system when the ambient temperature is below 0°C (32°F).

## CHECKING THE ENGINE AFTER OPERATION

- Check that the power switch is off and that the battery switch (if equipped) is turned to off.
- Fill the fuel tank. *See Filling the fuel tank: on page 29.*
- Close seawater cock(s).
- If there is a risk of freezing, check that the cooling system contains enough coolant. *See Engine Oil Specifications on page 30.*
- If there is a risk of freezing, drain the seawater system. *See Drain Seawater Cooling System on page 74.*
- At temperatures below 0°C (32°F), drain seawater system and connect the engine heater (if equipped).

**This Page Intentionally Left Blank**

# PERIODIC MAINTENANCE

---

## INTRODUCTION

This section of the *Operation Manual* describes the procedures for proper care and maintenance of the engine.

## SAFETY PRECAUTIONS

Before performing any maintenance procedures within this section, read the following safety information and review the *Safety* section on page 3.

### **WARNING**

#### **Crush Hazard**



If the engine needs to be transported for repair, have a helper assist you attach it to a hoist and load it on a truck.

---

The engine lifting eyes are engineered to lift the weight of the marine engine only. **ALWAYS** use the engine lifting eyes when lifting the engine.

---

Additional equipment is necessary to lift the marine engine and marine gear together. **ALWAYS** use lifting equipment with sufficient capacity to lift the marine engine.

---

### **WARNING**

#### **Welding Hazard**

- **ALWAYS** turn off the battery switch (if equipped) or disconnect the negative battery cable and the leads to the alternator when welding on the equipment.
- Remove the engine control unit multi-pin connector. Connect the weld clamp to the component to be welded and as close as possible to the welding point.
- **NEVER** connect the weld clamp to the engine or in a manner which would allow current to pass through a mounting bracket.
- When welding is completed, reconnect the alternator and engine control unit prior to reconnecting the batteries.

---

#### **Entanglement Hazard**



**NEVER** leave the power switch on when you are servicing the engine. Someone may accidentally start the engine and not realize you are servicing it.

---

#### **Shock Hazard**



**ALWAYS** turn off the battery switch (if equipped) or disconnect the negative battery cable before servicing the equipment.

---

**ALWAYS** keep the electrical connectors and terminals clean. Check the electrical harnesses for cracks, abrasions, and damaged or corroded connectors.

---

**NEVER** use undersized wiring for the electrical system.

---

#### **Tool Hazard**

**ALWAYS** remove any tools or shop rags used during maintenance from the area before operation.

### **NOTICE**

Any part which is found defective as a result of inspection, or any part whose measured value does not satisfy the standard or limit, must be replaced.

---

Modifications may impair the engine's safety and performance characteristics and shorten the engine's life. Any alterations to this engine may void its warranty. Be sure to use Yanmar genuine replacement parts.

---



## PRECAUTIONS

### The Importance of Periodic Maintenance

Engine deterioration and wear occur in proportion to the length of time the engine has been in service and the conditions the engine is subjected to during operation. Periodic maintenance prevents unexpected downtime, reduces the number of accidents due to poor machine performance and helps extend the life of the engine.

### Performing Periodic Maintenance

#### WARNING

#### Exhaust Hazard.

**NEVER block windows, vents, or other means of ventilation if the engine is operating in an enclosed area. All internal combustion engines create carbon monoxide gas during operation. Accumulation of this gas within an enclosure could cause illness or even death. Make sure that all connections are tightened to specifications after repair is made to the exhaust system. Failure to comply could result in death or serious injury.**

### The Importance of Daily Checks

The Periodic Maintenance Schedule assumes that the daily checks are performed on a regular basis. Make it a habit to perform daily checks before the start of each operating day. *See Daily Checks on page 56.*

### Keep a Log of Engine Hours and Daily Checks

Keep a log of the number of hours the engine is run each day and a log of the daily checks performed. Also note the date, type of repair (e.g., replaced alternator) and parts used for any service needed between the periodic maintenance intervals. Periodic maintenance intervals are every 50, 125, 250, 500, 1000 and 1250 engine hours. Failure to perform periodic maintenance will shorten the life of the engine.

#### NOTICE

Failure to perform periodic maintenance will shorten the life of the engine and may void the warranty.

### Yanmar Replacement Parts

Yanmar recommends that you use genuine Yanmar parts when replacement parts are needed. Genuine replacement parts help ensure long engine life.

### Tools Required

Before you start any periodic maintenance procedure, make sure you have the tools you need to perform all of the required tasks.

### Ask Your Authorized Yanmar Marine Dealer or Distributor for Help

Our professional service technicians have the expertise and skills to help you with any maintenance or service related procedures you need help with.

# PERIODIC MAINTENANCE

## Tightening Fasteners

Use the correct amount of torque when you tighten fasteners on the engine. Applying excessive torque may damage the fastener or component and not enough torque may cause a leak or component failure.

### NOTICE



The tightening torque in the Standard Torque Chart should be applied only to the bolts with a “7” head (JIS strength classification: 7T). Apply 60% torque to bolts that are not listed. Apply 80% torque when tightened to aluminum alloy.

Bolt Diameter x Pitch (mm)		M6x1.0	M8x1.25	M10x1.5	M12x1.75	M14x1.5	M16x1.5
Tightening Torque	N·m	11 ± 1.0	25 ± 3	49 ± 5	88 ± 10	140 ± 10	230 ± 10
	ft·lb	8.0 ± 0.7	18.8 ± 2.2	36.2 ± 3.7	65.1 ± 7.4	103 ± 7.2	170 ± 7.2

Taper Plugs		1/8	1/4	3/8	1/2
Tightening Torque	N·m	10	20	29	59
	ft·lb	7.4	14.5	21.7	43.2

When lock adhesive is applied, decide separately.

Pipe Joint Bolts		M8	M10	M12	M14	M16
Tightening Torque	N·m	15 ± 2	23 ± 3	29 ± 5	44 ± 5	54 ± 5
	ft·lb	10.9 ± 1.5	16.6 ± 2.2	21.7 ± 3.7	32.6 ± 3.7	69.8 ± 3.7

## PERIODIC MAINTENANCE SCHEDULE

Daily and periodic maintenance is important to keep the engine in good operating condition. The following is a summary of maintenance items by periodic maintenance intervals. Periodic maintenance intervals vary depending on engine application, loads, diesel fuel and engine oil used and are hard to establish definitively. The following should be treated only as a general guideline.

### NOTICE

Establish a periodic maintenance plan according to the engine application and make sure to perform the required periodic maintenance at the intervals indicated. Failure to follow these guidelines will impair the engine's safety and performance characteristics, shorten the engine's life and may affect the warranty coverage on your engine.

*See your authorized Yanmar Marine dealer or distributor for assistance when checking items marked with a ●.*

---

# PERIODIC MAINTENANCE

○: Check or Clean ◇: Replace ●: Contact your authorized Yanmar marine dealer or distributor								
System	Item	Periodic Maintenance Interval						
		Daily	Every 50 hours or monthly whichever comes first	Every 125 hours or 6 months whichever comes first	Every 250 hours or 1 year whichever comes first	Every 500 hours or 2 years whichever comes first	Every 1000 hours or 4 years whichever comes first	Every 1250 hours or 5 years whichever comes first
Whole	Visual inspection of engine exterior	○						
Fuel System	Check the fuel level and refill if necessary	○						
	Drain water and sediment from fuel tank		○					
	Drain the fuel /water separator		○					
	Replace the fuel filter element		◇ Initial 50		◇			
	Check the fuel injection timing						●*	
	Check the fuel injector pressure and nozzle spray pattern*				● Initial 250		●*	
Lubricating System	Check the engine oil level	○						
	Change the engine oil		◇ Initial 50	◇				
	Replace the engine oil filter element		◇ Initial 50	◇				
	Wash the engine oil cooler							●
Marine Drive System	Check the marine drive oil	○	Refer to the marine drive system operation manual.					
	Check power steering oil	○						
	Check power trim oil	○						
	Check drive oil	○						
Fresh Water Cooling System	Check coolant level	○						
	Change coolant				◇			
	Clean and check the cooling water passage							●
	Clean the cooling water system							●

# PERIODIC MAINTENANCE

1007

○: Check or Clean ◇: Replace ●: Contact your authorized Yanmar marine dealer or distributor								
System	Item	Periodic Maintenance Interval						
		Daily	Every 50 hours or monthly whichever comes first	Every 125 hours or 6 months whichever comes first	Every 250 hours or 1 year whichever comes first	Every 500 hours or 2 years whichever comes first	Every 1000 hours or 4 years whichever comes first	Every 1250 hours or 5 years whichever comes first
Seawater Cooling System	Check seawater outlet discharge	○ During Operation						
	Check or replace the seawater pump impeller						●	
	Check or replace the zinc anodes				◇			
	Check and clean the seawater passage							●
Piping	Clean or replace the exhaust / water mixing elbow						●	
	Check or replace fuel line and rubber hoses	○					●	
Electrical System	Check the alarm and indicators	○						
	Check the electrolyte level in the battery		○					
	Adjust the tension of the alternator V-belt or replace V-belt					○		●
Remote Control Handle	Check and lubricate the remote control cable operation	○						
	Adjust the remote control cable				○			
Intake and Exhaust System	Wash turbo-charger blower				●			
	Clean air cleaner				○			
	Adjust the intake and exhaust valve clearance				● Initial 250		●	
	Lap the intake and exhaust valves						●	
Miscellaneous	Check and adjust the power steering oil pump belt (6LPA-STZP2)					○		
	Replace the timing belt							●
	Replace the front rubber damper							●

Note: These procedures are considered normal maintenance and are performed at the owner's expense.

### PERIODIC MAINTENANCE PROCEDURES

#### WARNING

**Exposure Hazard.**

**ALWAYS wear personal protective equipment when performing periodic maintenance procedures.**

---

#### Daily Checks

Before you head out for the day, make sure the Yanmar engine is in good operating condition.

#### NOTICE

It is important to perform the daily checks as listed in this Operation Manual. Periodic maintenance prevents unexpected downtime, reduces the number of accidents due to poor engine performance and helps extend the life of the engine.

---

Make sure you check the following items.

#### Visual Checks

1. Check for engine oil leaks.
2. Check for fuel leaks.

#### WARNING

**Piercing Hazard.**

**Avoid skin contact with the high-pressure diesel fuel spray caused by a fuel system leak, such as a broken fuel injection line.**

**High-pressure fuel can penetrate your skin and result in serious injury. If you are exposed to high-pressure fuel spray, obtain prompt medical treatment.**

**NEVER check for a fuel leak with your hands.**

**ALWAYS use a piece of wood or cardboard. Have your authorized Yanmar Marine dealer or distributor repair any damage.**

---

3. Check for engine coolant leaks.
4. Check for damaged or missing parts.
5. Check for loose, missing or damaged fasteners.
6. Check the electrical harnesses for cracks, abrasions, and damaged or corroded connectors.
7. Check hoses for cracks, abrasions, and damaged, loose or corroded clamps.
8. Check the fuel filter / water separator for presence of water and contaminants. If you find any water or contaminants, drain the fuel filter / water separator. *See Draining Fuel Filter / Water Separator on page 60.* If you have to drain the fuel filter / water separator frequently, drain the fuel tank and check for the presence of water in your fuel supply. *See Draining Water From the Fuel Tank on page 60.*

#### NOTICE

If any problem is noted during the visual check, the necessary corrective action should be taken before operating the engine.

---

#### Check Diesel Fuel, Engine Oil and Engine Coolant Levels

Follow the procedures in *Diesel Fuel on page 26*, *Engine Oil on page 30* and *Engine coolant on page 33* to check these levels.

## Checking and Refilling Marine Drive Oil

See *Marine Drive Oil* on page 32.

## Checking the Battery Electrolyte Level

Check the battery electrolyte level before use. See *Checking the Battery Electrolyte Level (Serviceable Batteries Only)* on page 61.

## Checking the Alternator Belt

Check the belt tension before use. See *Checking and Adjusting the Alternator V-Belt Tension* on page 66.

## Checking the Remote Control Handle

Check the operation of the remote control handle and ensure it moves smoothly. If it is hard to operate, grease the joints of the remote control cable and lever bearings. If the lever is too loose, adjust the remote control cable. See *Checking and Adjusting Remote Control Cables* on page 64.

## Checking the Alarm Indicators

When operating the start switch on the instrument panel, check that there is no alarm message on the display and the alarm indicators work normally. See *Control Equipment* on page 15.

## Preparing Fuel, Oil and Coolant in Reserve

Prepare sufficient fuel for the days operation. Always store engine oil and coolant in reserve (for at least one refill) onboard, to be ready for emergencies.

## After Initial 50 Hours of Operation

Perform the following maintenance after the initial 50 hours of operation.

- **Changing the Engine Oil and Replacing the Engine Oil Filter Element**
- **Changing the Fuel Filter Element**

## Changing the Engine Oil and Replacing the Engine Oil Filter Element

The engine oil on a new engine becomes contaminated from the initial break-in of internal parts. It is very important that the initial oil replacement is performed as scheduled.

It is easiest and most effective to drain the engine oil after operation while the engine is still warm.

## **WARNING**

**If you must drain the engine oil while it is still hot, stay clear of the hot engine oil to avoid being burned. ALWAYS wear eye protection.**

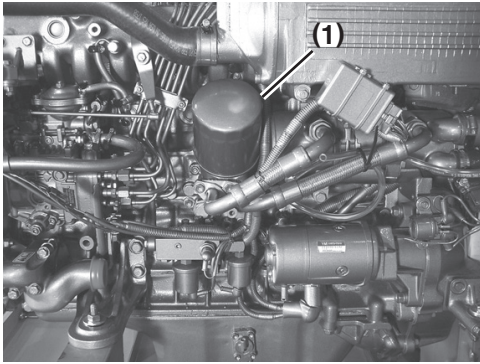

0004899

**Figure 1**

1. Turn the engine OFF.
2. Remove the engine oil dipstick. Attach the oil drain pump (if equipped) and pump out the oil.

For easier draining, remove the engine oil fill cap.

## NOTICE

Prevent dirt and debris from contaminating engine oil. Carefully clean the dipstick and the surrounding area before you remove the dipstick.

3. Turn the engine oil filter (**Figure 1, (1)**) counterclockwise with a wrench.
4. Remove the engine oil filter.
5. Apply a small amount of engine oil to the seal of the new filter.
6. Install a new filter element and tighten by hand until the seal touches the housing.
7. Turn filter an additional 3/4 turn with a filter wrench.

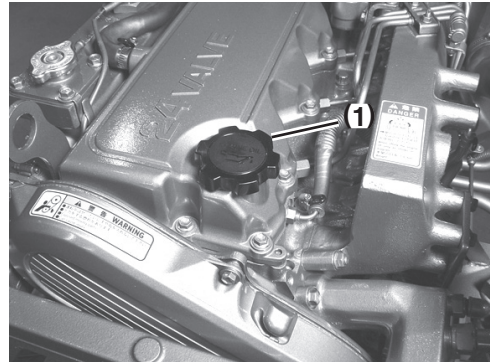

0004900

**Figure 2**

8. Remove filler cap (**Figure 2, (1)**) and fill with new engine oil through filler port.  
*See Engine Oil on page 30.*

## NOTICE

NEVER mix different types of engine oil. This may adversely affect the lubricating properties of the engine oil.  
NEVER overfill. Overfilling may result in white exhaust smoke, engine overspeed or internal damage.

9. Perform a trial run and check for oil leaks.
10. Approximately 10 minutes after stopping the engine, remove the oil dipstick and check the oil level. Add oil if the level is too low.
11. Dispose of waste properly.



Replacing the Fuel Filter Element

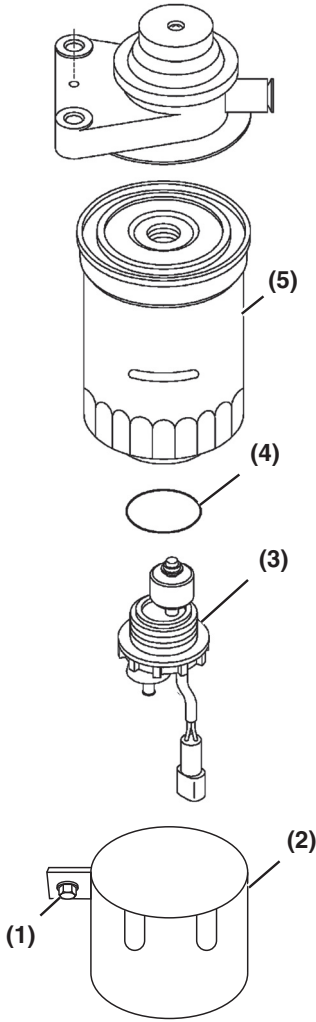

Figure 3

- 1 – Mounting Screw (2 used)
- 2 – Housing
- 3 – Alarm Switch
- 4 – O-Ring
- 5 – Filter Element

1. Close the fuel cock of the fuel tank.
2. Remove the two mounting screws (Figure 3, (1)) and the housing (Figure 3, (2)).

3. Drain the fuel from the fuel drain cock on the bottom of the fuel / water separator.
4. Disconnect the alarm switch harness.

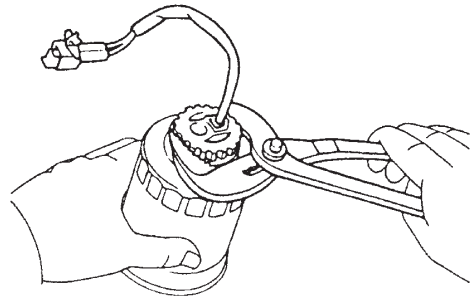

Figure 4

5. Remove the alarm switch (Figure 3) with a wrench.
6. Remove the filter element (Figure 3, (5)) with a filter wrench.
7. Install the alarm switch to the new fuel filter.

Component	Part No.
Fuel Filter Element	119773-55710

8. Apply a thin film of clean diesel fuel to the sealing surface of the new filter gasket.
9. Install new filter and tighten hand-tight. Use a filter wrench and tighten to 14.7 - 19.6 N·m (130.1 - 173.5 in.-lb).
10. Install filter and tighten hand-tight.
11. Connect the alarm switch harness.
12. Install the housing and mounting screws.
13. Bleed the fuel system. See *Bleeding the Fuel System* on page 29. Dispose of waste properly.
14. Start engine and check for leaks.

## Every 50 Hours of Operation

After you complete the initial 50 hour maintenance procedures, perform the following procedures every 50 hours thereafter or monthly, whichever comes first.

- Draining Water From the Fuel Tank
- Draining Fuel Filter / Water Separator
- Checking Battery Electrolyte Level

### Draining Water From the Fuel Tank

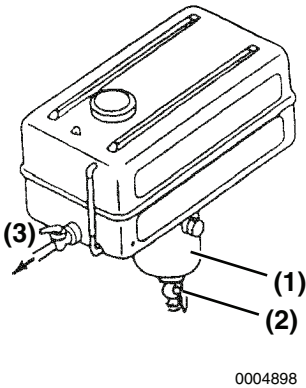

**Figure 5**

- 1 – Sediment Bowl**
- 2 – Drain Cock**
- 3 – Fuel Line To Engine**

1. Put a pan under the drain cock (**Figure 5, (2)**) to catch fuel.
2. Open the drain cock and drain water and sediment. Close the drain cock when the fuel is clean and free of air bubbles.

## NOTICE

Dispose of waste properly.

### Draining Fuel Filter / Water Separator

Water and sediment can clog the fuel filter and impair the function of the fuel injection pump and valve. If heavy deposits of water and sediment are drained, also drain the fuel tank.

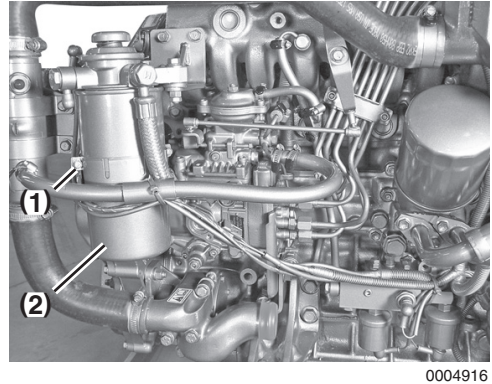

**Figure 6**

1. Close the fuel cock of the fuel tank.
2. Remove the two mounting screws (**Figure 6, (1)**) and remove the housing (**Figure 6, (2)**).
3. Put a pan under the drain cock.
4. Loosen the drain cock of the water separator and drain off any water or dirt collected inside.
5. Install housing and mounting screws.
6. Bleed air from the fuel system. See *Bleeding the Fuel System on page 29*.

## Checking the Battery Electrolyte Level (Serviceable Batteries Only)

### **⚠ WARNING**

Batteries contain sulfuric acid. NEVER allow battery fluid to come in contact with clothing, skin or eyes. Severe burns could result. ALWAYS wear safety goggles and protective clothing when servicing the battery. If battery fluid contacts the eyes and / or skin, immediately flush the affected area with a large amount of clean water and obtain prompt medical treatment.

### **NOTICE**

NEVER turn off the battery switch (if equipped) or short the battery cables during operation. Damage to the electric system will result.

Note: Battery fluid tends to evaporate in high temperatures, especially in summer. In such conditions, inspect the battery earlier than specified.

1. Turn the battery master switch to OFF (if equipped) or disconnect the negative (-) battery cable.
2. Do not operate with insufficient battery electrolyte as the battery will be destroyed.
3. Remove the plugs and check the electrolyte level in all cells.

### **NOTICE**

NEVER attempt to remove the covers or fill a maintenance-free battery.

4. If the level is lower than the minimum fill level (**Figure 7**), fill with distilled water (**Figure 7**) (available in the grocery store) up to the upper limit (**Figure 7**) of the battery.

### **⚠ WARNING**

If operation continues with insufficient battery fluid, the battery life is shortened, and the battery may overheat and explode.

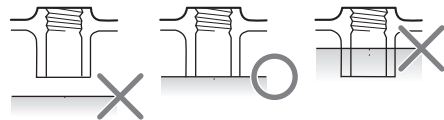
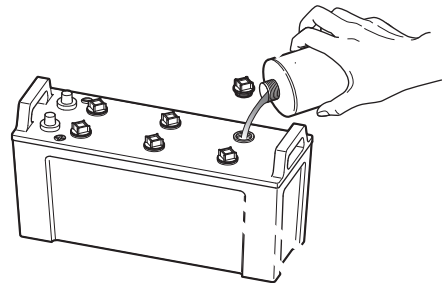

0004566\_s1

**Figure 7**

### Every 125 Hours of Operation

Perform the following maintenance every 125 hours of operation or 6 months, whichever comes first.

- **Changing the Engine Oil and Replacing the Engine Oil Filter**

#### **Changing the Engine Oil and Replacing the Engine Oil Filter**

*See Changing the Engine Oil and Replacing the Engine Oil Filter Element on page 57.*

### After Initial 250 Hours of Operation

Perform the following maintenance after the initial 250 hours of operation.

- **Checking the Fuel Injector Spray Pattern**
- **Inspecting and Adjusting Intake / Exhaust Valve Clearance**

#### **Checking the Fuel Injector Spray Pattern**

See your authorized Yanmar Marine dealer or distributor.

#### **Inspecting and Adjusting Intake / Exhaust Valve Clearance**

Proper adjustment is necessary to maintain the correct timing for opening and closing the valves. Improper adjustment will cause the engine to run noisily, resulting in poor engine performance and engine damage. See your authorized Yanmar Marine dealer or distributor to adjust the intake / exhaust valve clearance.

**Every 250 Hours of Operation**

Perform the following maintenance every 250 hours or one year of operation, whichever comes first.

- Replacing the Fuel Filter Element
- Changing the Coolant
- Checking or Replacing the Zinc Anodes
- Adjusting the Remote Control Cable
- Cleaning the Turbocharger
- Cleaning the Air Cleaner

**Replacing the Fuel Filter Element**

See *Replacing the Fuel Filter Element* on page 59.

**Changing the Coolant**

Replace the coolant every year.

Note: If Long Life coolant is used, replace coolant every 2 years.

1. Drain the fresh water cooling system. See *Drain Seawater Cooling System* on page 74.
2. Fill the cooling system with clean coolant. See *Checking and Adding Coolant* on page 34.

**Checking or Replacing Zinc Anodes**

Inspect and replace the zinc anodes periodically.

**NOTICE**

If zinc anodes are not replaced periodically, corrosion and engine damage will result.

1. Close the seacock.

2. Drain the seawater cooling system. See *Drain Seawater Cooling System* on page 74.

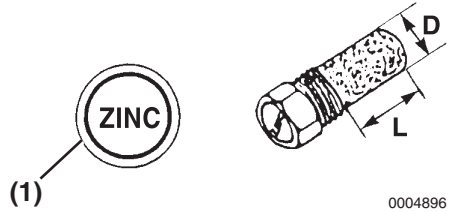

0004896

**Figure 8**

3. Remove all the plugs ((**Figure 9, (1)**), (**Figure 10, (3)**), (**Figure 11, (4)**), (**Figure 12, (2)**) and (**Figure 13, (2)**)) labeled ZINC (**Figure 8, (1)**).
4. Measure the remaining zinc in the plug. Replace the zinc anode when it is less than one-half its original size. See chart for sizes.
5. Install a new zinc in a new plug.

**NOTICE**

NEVER use sealing tape to install the zinc anode. The anode must make metal-to-metal contact.

6. Install plug.
7. Open the seacock and check for leaks.

**Fuel Cooler**

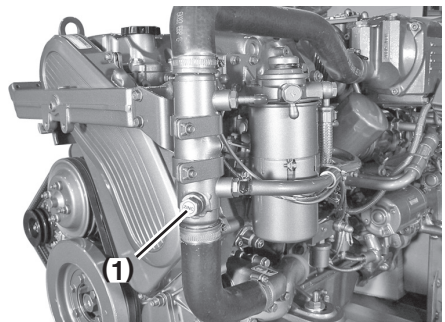

0004918

**Figure 9**

## Fresh Water Cooler

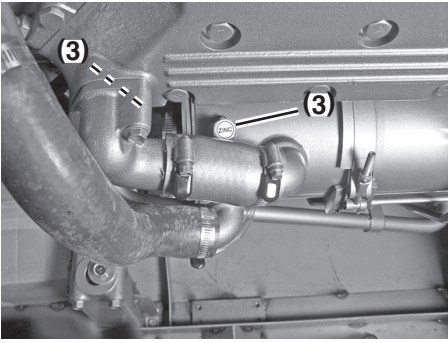

0004919

**Figure 10**

## Intercooler

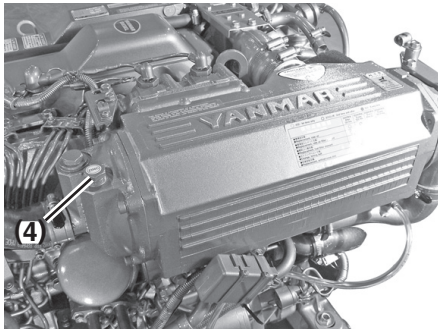

0004917

**Figure 11**

## Engine Oil Cooler

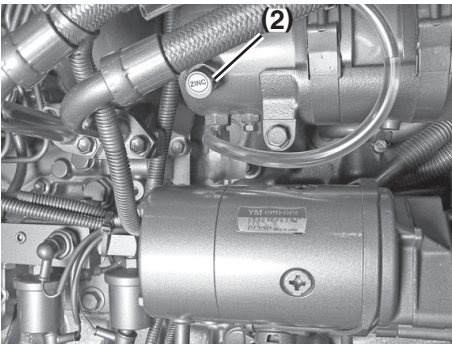

0004920

**Figure 12**

## Engine Oil Cooler

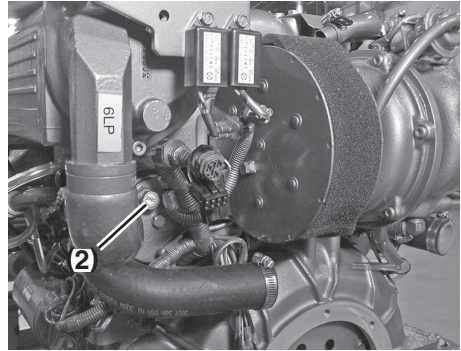

0004921

**Figure 13**

Location	Part Number	Qty.	Dimensions D x L
Fuel Cooler	119574-44150	1	0.5 x 1.0 in.
Engine Oil Cooler	119574-44150	2	0.5 x 1.0 in.
Fresh Water Cooler	119574-44150	2	0.5 x 1.0 in.
Inter-Cooler	119574-18790	1	0.5 x 1.0 in.

Note: Some marine drives have additional zinc anodes. Check the manufacturer's documentation for location and other information.

## Checking and Adjusting Remote Control Cables

Note: Never adjust the high speed stop bolt on the governor. This will void the engine warranty.

### **Adjusting Engine Speed (Governor) Remote Control Cable**

See your authorized Yanmar dealer or distributor.

### **Adjusting Clutch Remote Control Cable**

Refer to the manufacturer's documentation.

## Cleaning the Turbocharger

Contamination of the turbocharger causes revolutions to drop and engine output to fall.

If a significant drop in engine output is noted (10% or more), clean the turbocharger.

This should be done only by a trained and qualified technician. See your authorized Yanmar Marine dealer or distributor.

## Cleaning the Air Cleaner

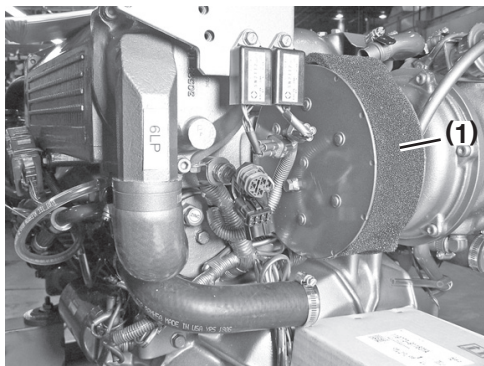

0004911

**Figure 14**

1. Slide air cleaner (**Figure 14, (1)**) off air inlet.
2. Clean the air cleaner with detergent.
3. Allow to air dry and install on the air inlet.

## NOTICE

Replace the air cleaner if unable to clean or if damaged.

## Every 500 Hours of Operation

Perform the following maintenance every 500 hours or 2 years of operation, whichever comes first.

- **Cleaning or Replacing Exhaust / Water Mixing Elbow**
- **Replacing Fuel Line and Rubber Hoses**
- **Adjusting or Replacing the Alternator V-Belt**
- **Checking and Adjusting the Power Steering Oil Pump Belt (6LPA-STZP2 Models)**

### Cleaning or Replacing Exhaust / Water Mixing Elbow

See your authorized Yanmar dealer or distributor.

### Replacing Fuel Line and Rubber Hoses

Replace fuel line and rubber hoses every 500 hours or 2 years, whichever comes first.

See your authorized Yanmar Marine dealer or distributor.

## PERIODIC MAINTENANCE

### Checking and Adjusting the Alternator V-Belt Tension

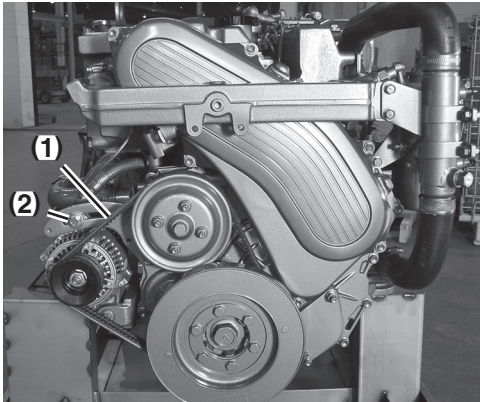

0004903

Figure 15

### NOTICE

NEVER get any oil on the belt(s). Oil on the belt causes slipping and stretching. Replace the belt if it is damaged. NEVER over-tighten the belt(s). Engine damage will result.

1. Check the belt by pushing on the middle of the belt (**Figure 15, (1)**) with your finger.  
With proper tension, the belt should deflect 8 - 10 mm (approximately 3/8 in.).
2. Loosen the alternator bolt (**Figure 15, (2)**) and move the alternator to adjust the V-belt tension.
3. Replace the V-belt if required.

Alternator V-Belt Part Number
119775-77260

### Checking and Adjusting the Power Steering Oil Pump Belt (6LPA-STZP2 Models)

### NOTICE

NEVER get any oil on the belt(s). Oil on the belt causes slipping and stretching. Replace the belt if it is damaged. NEVER over-tighten the belt(s). Engine damage will result.

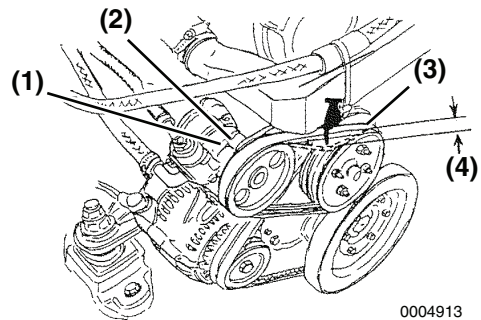

0004913

Figure 16

1. Check the belt by pushing on the middle of the belt (**Figure 16, (3)**) with your finger.  
With proper tension, the belt should deflect 8 - 10 mm (approximately 3/8 in.) (**Figure 16, (4)**).
2. Loosen the power steering pump bolt (**Figure 16, (2)**) and move the oil pump (**Figure 16, (1)**) to adjust the belt tension.
3. Replace the belt if required.

Power Steering Oil Pump Belt Part Number (6LPA-STZP2 only)
119787-26540



1287

**Every 1000 Hours of Operation**

Perform the following maintenance every 1000 hours or 4 years of operation, whichever comes first.

- **Checking the Fuel Injection Timing**
- **Checking the Fuel Injector Pressure and Nozzle Spray Pattern**
- **Replacing the Seawater Pump Impeller**
- **Adjusting Intake / Exhaust Valve Clearance**
- **Lapping the Intake and Exhaust Valves**

**Checking the Fuel Injection Timing**

See your authorized Yanmar Marine dealer or distributor.

**Checking the Fuel Injector Pressure and Nozzle Spray Pattern**

See your authorized Yanmar Marine dealer or distributor.

**Checking or Replacing Seawater Pump Impeller**

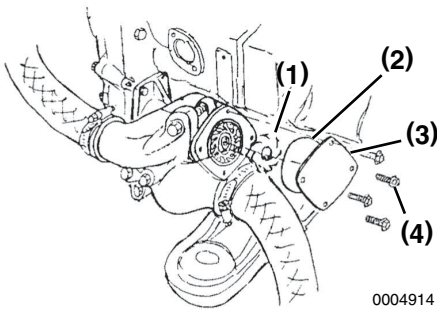

**Figure 17**

- 1 – Impeller**
- 2 – O-Ring**
- 3 – Cover**
- 4 – Cover Bolts**

1. Close the seacock.
2. Drain the seawater cooling system. See *Drain Seawater Cooling System on page 74.*
3. Loosen the cover bolts and remove the cover and O-ring.
4. Inspect the inside of the seawater pump with a flashlight. If any of the following are found, disassembly and maintenance are required:
  - Impeller blades are cracked or nicked. Edges or surfaces of the blades are marred or scratched.
  - Wear plate is damaged.
5. If no damage is found when inspecting the inside of the pump, install the O-ring and cover.
6. If a large amount of water leaks continuously from the water drain line below the seawater pump during operation, replace the mechanical seal. See your authorized Yanmar Marine dealer or distributor.
7. When replacement is required, see your authorized Yanmar Marine dealer or distributor.

**NOTICE**

Replace the seawater pump impeller every 1000 hours even if no damage is apparent.

**Adjusting Intake / Exhaust Valve Clearance**

See your authorized Yanmar Marine dealer or distributor.

**Lapping the Intake and Exhaust Valve**

See your authorized Yanmar Marine dealer or distributor.

### Every 1250 Hours of Operation

Perform the following maintenance procedures every 1250 hours of operation or 5 years, whichever comes first.

- **Cleaning the Cooling Water System**
- **Cleaning and Checking the Seawater Passage**
- **Cleaning and Checking the Fresh Water Cooling Water Passage**
- **Adjusting the Tension of the Alternator V-Belt**
- **Replacing the Timing Belt**
- **Washing Engine Oil Cooler**
- **Replacing the Front Rubber Damper**

### Cleaning the Cooling Water System

See your authorized Yanmar Marine dealer or distributor.

### Cleaning and Checking the Seawater Passage

See your authorized Yanmar Marine dealer or distributor.

### Cleaning and Checking the Fresh Water Cooling Water Passage

See your authorized Yanmar Marine dealer or distributor.

### Adjusting the Tension of the Alternator V-Belt

*See Checking and Adjusting the Alternator V-Belt Tension on page 66.*

### Replacing the Timing Belt

See your authorized Yanmar Marine dealer or distributor.

### Washing the Engine Cooler

See your authorized Yanmar Marine dealer or distributor.

### Replacing the Front Rubber Damper

See your authorized Yanmar Marine dealer or distributor.

# TROUBLESHOOTING

---

## SAFETY PRECAUTIONS

Before performing any troubleshooting procedures within this section, review the *Safety* section on page 3.

If a problem occurs, stop the engine immediately. Refer to the Symptom column in the Troubleshooting Chart to identify the problem.

## TROUBLESHOOTING AFTER STARTING

Just after the engine has started, check the following items at a low engine speed:

### **Is sufficient water being discharged from the seawater outlet pipe?**

If the discharge is low, stop the engine immediately. Identify the cause and repair.

### **Is the smoke color normal?**

The continuous emission of black exhaust smoke indicates engine overloading. This shortens the engines life and should be avoided.

### **Are there abnormal vibrations or noise?**

Depending on the hull structure, engine and hull resonance may suddenly increase at certain engine speed ranges, causing heavy vibrations. Avoid operation in this speed range. If any abnormal sounds are heard, stop the engine and inspect for cause.

### **Alarm sounds during operation.**

If the alarm sounds during operation, lower the engine speed immediately, check the alarm lamps and stop the engine for repairs.

## TROUBLESHOOTING

---

### Is there water, oil or fuel leakage? Are there any loose bolts or connections?

Check the engine room daily for any leaks or loose connections.

### Is there sufficient fuel in the fuel tank?

Refill fuel in advance to avoid running out of fuel. If the tank runs out of fuel, bleed the fuel system. See *Bleeding the Fuel System on page 29*.

When operating the engine at low speed for long periods of time, race the engine once every 2 hours. Racing the engine with the clutch in NEUTRAL, accelerate from the low-speed position to the high-speed position and repeat this process about five times. This is done to clean out carbon from the cylinders and the fuel injection valves.

### NOTICE

Neglecting to race the engine will result in poor smoke color and reduce engine performance.

---

Periodically operate the engine near maximum speed while underway. This will generate higher exhaust temperatures, which will help clean out hard carbon deposits, maintain engine performance and prolong the life of the engine.

## TROUBLESHOOTING INFORMATION

If the engine does not operate properly, refer to the *Troubleshooting Chart on page 71* or see your authorized Yanmar Marine dealer or distributor.

Supply the authorized Yanmar Marine dealer or distributor with the following information:

- Model name and serial number of your engine
- Boat model, hull material, size (tons)
- Use, type of boating, number of hours run
- Total number of operation hours (refer to hourmeter), age of boat
- The operating conditions when the problem occurs:
  - Engine speed (min<sup>-1</sup>)
  - Color of smoke
  - Type of diesel fuel
  - Type of engine oil
  - Any abnormal noises or vibration
  - Operating environment such as high altitude or extreme ambient temperatures, etc.
  - Engine maintenance history and previous problems
  - Other factors that contribute to the problem

**TROUBLESHOOTING CHART**

Symptom	Probable Cause	Measure	Reference
Indicators light on the instrument panel and alarm sounds during operation	Shift to low speed operation immediately, and check which indicator has come on. Stop the engine and inspect. If no abnormality is identified and there is no problem with operation, return to port at lowest speed and request repairs.		
• Engine oil low pressure alarm indicator comes on	Engine oil level is low.	Check engine oil level. Add or replace.	<i>See Adding Engine Oil on page 31.</i>
	Engine oil filter clogged.	Replace engine oil filter. Replace engine oil.	<i>See Changing the Engine Oil and Replacing the Engine Oil Filter Element on page 57.</i>
• Fresh water (coolant) level alarm comes on	Coolant / fresh water in coolant recovery tank is low.	Check coolant level and refill.	<i>See Checking and Adding Coolant on page 34.</i>
• Fresh water (coolant) high temperature alarm comes on	Coolant / fresh water in coolant recovery tank is low.	Check coolant level and refill.	<i>See Checking and Adding Coolant on page 34.</i>
	Leakage in fresh water cooling system causing temperature to rise.	See your authorized Yanmar Marine dealer or distributor.	-
	Contamination inside cooling system.	See your authorized Yanmar Marine dealer or distributor.	-
	Fresh water cooling pump damaged.	See your authorized Yanmar Marine dealer or distributor.	-
• Gear oil alarm comes on	Insufficient drive oil.	Check oil level and refill.	<i>See Marine Drive Oil on page 32</i>
• Fuel filter alarm comes on	Water level in fuel / water separator too high.	Drain.	<i>See Draining Fuel Filter / Water Separator on page 60.</i>
• Exhaust alarm comes on	Insufficient discharge of cooling seawater. Check that seacock is open. Damaged seawater pump.	See your authorized Yanmar Marine dealer or distributor.	-
Faulty Warning Devices	Do not operate the engine if alarm devices are not repaired. Serious accidents may result if abnormalities are not identified due to faulty indicators or alarm.		
Indicators Do Not Go On:			
• When key is turned ON • When any trouble occurs (oil pressure etc.)	No electrical current available. Circuit broken or lamp burned out.	See your authorized Yanmar Marine dealer or distributor.	-
	• One of the indicators does not go out	Sensor switch is faulty.	See your authorized Yanmar Marine dealer or distributor.
• Battery low charge indicator does not go out during operation	V-belt is loose or broken.	Replace V-belt or adjust tension.	<i>See Checking and Adjusting the Alternator V-Belt Tension on page 66.</i>
	Battery is defective.	Check battery fluid level, specific gravity or replace battery.	<i>See Checking the Battery Electrolyte Level on page 57.</i>
	Alternator power generation failure.	See your authorized Yanmar Marine dealer or distributor.	-

# TROUBLESHOOTING

Symptom	Probable Cause	Measure	Reference
Starting Failures:			
<ul style="list-style-type: none"> <li>Starter turns but engine does not start</li> </ul>	No fuel.	Add fuel. Bleed fuel system.	See <i>Filling the Fuel Tank</i> on page 28 and See <i>Bleeding the Fuel System</i> on page 29.
	Air in fuel line.	Bleed fuel system.	See <i>Bleeding the Fuel System</i> on page 29.
	Fuel filter is clogged.	Replace filter element.	See <i>Replacing the Fuel Filter Element</i> on page 63.
	Improper fuel.	Replace with recommended fuel.	See <i>Diesel Fuel Specifications</i> on page 26.
	Problem with fuel injection.	See your authorized Yanmar Marine dealer or distributor.	-
	Compression leakage from intake / exhaust valve.	See your authorized Yanmar Marine dealer or distributor.	-
<ul style="list-style-type: none"> <li>Starter does not turn or turns slowly (engine can be turned manually)</li> </ul>	Faulty clutch position.	Shift to NEUTRAL and start.	-
	Insufficient battery charge.	Check fluid level. Recharge. Replace.	See <i>Checking the Battery Electrolyte Level</i> on page 57.
	Cable terminal contact failure.	Remove corrosion from terminals. Tighten battery cables.	-
	Faulty safety switch device.	See your authorized Yanmar Marine dealer or distributor.	-
	Faulty starter switch.	See your authorized Yanmar Marine dealer or distributor.	-
	Power lacking due to accessory drive being engaged.	See your authorized Yanmar Marine dealer or distributor.	-
<ul style="list-style-type: none"> <li>Engine cannot be turned manually</li> </ul>	Internal parts seized.	See your authorized Yanmar Marine dealer or distributor.	-
Abnormal Exhaust Color:			
<ul style="list-style-type: none"> <li>Black smoke</li> </ul>	Overload	Reduce load.	-
	Improper propeller matching.	See your authorized Yanmar Marine dealer or distributor.	-
	Dirty air cleaner.	Clean air cleaner.	See <i>Cleaning the Air Cleaner</i> on page 65.
	Improper fuel.	Replace with recommended fuel.	See <i>Diesel Fuel Specifications</i> on page 26.
	Faulty spraying of fuel injector.	See your authorized Yanmar Marine dealer or distributor.	-
	Low boost pressure.	See your authorized Yanmar Marine dealer or distributor.	-
	Incorrect intake / exhaust valve clearance.	See your authorized Yanmar Marine dealer or distributor.	-
<ul style="list-style-type: none"> <li>White smoke</li> </ul>	Improper fuel.	Replace with recommended fuel.	See <i>Diesel Fuel Specifications</i> on page 26.
	Faulty spraying of fuel injector.	See your authorized Yanmar Marine dealer or distributor.	-
	Fuel injection timing off.	See your authorized Yanmar Marine dealer or distributor.	-
	Engine burning oil (excessive consumption).	See your authorized Yanmar Marine dealer or distributor.	-

# LONG-TERM STORAGE

---

If the engine will not be used for an extended period of time, special measures should be taken to protect the cooling system, fuel system and combustion chamber from corrosion and the exterior from rusting.

The engine can normally stand idle for up to 6 months. If it remains unused for longer than this, please contact your authorized Yanmar Marine dealer or distributor.

Before performing any storage procedures within this section, review the *Safety* section on page 3.

In cold temperatures or before long-term storage, be sure to drain the seawater from the cooling system.

## NOTICE

DO NOT drain the coolant system. A full coolant system will prevent corrosion and frost damage.

---

If seawater is left inside of the engine, it may freeze and damage parts of the cooling system when the ambient temperature is below 0°C (32°F).

---

## PREPARE ENGINE FOR LONG-TERM STORAGE

Note: If the engine is close to a periodic maintenance interval, perform those maintenance procedures before putting the engine into long-term storage.

1. Wipe off any dust or oil from the outside of engine.
2. Drain water from fuel filters.
3. Drain fuel tank completely or fill the tank to prevent condensation.
4. Grease the exposed areas and joints of the remote control cables and the bearings of the remote control handle.
5. Seal the intake silencer, exhaust pipe, etc. to prevent moisture or contamination from entering engine.
6. Completely drain bilge in hull bottom.
7. Waterproof the engine room to prevent rain or seawater from entering.
8. Charge the battery once a month to compensate for battery's self-discharge.
9. Remove key from key switch and cover the key switch with moisture cap.

## DRAIN SEAWATER COOLING SYSTEM

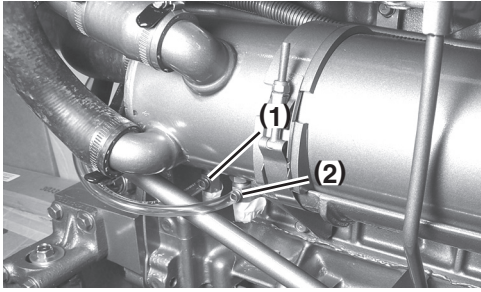

0004904

**Figure 1**

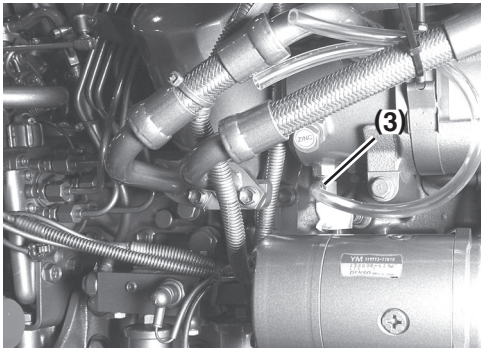

0004905

**Figure 2**

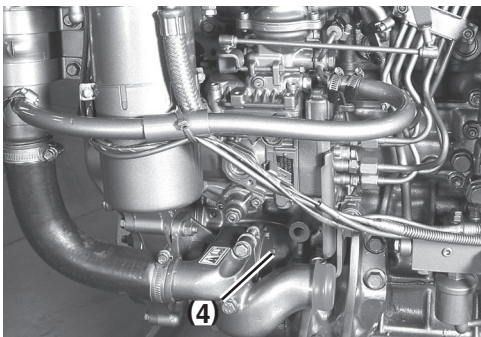

0004906

**Figure 3**

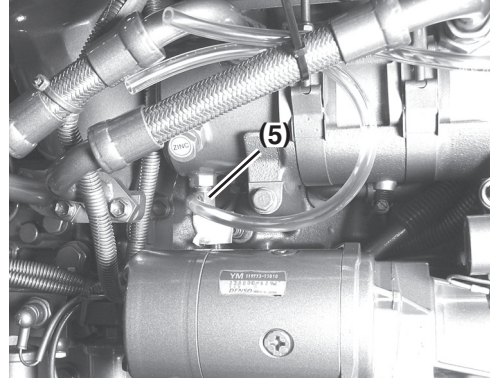

0004907

**Figure 4**

- 1 – Seawater Drain Cock
- 2 – Fresh Water Drain Cock
- 3 – Fresh Water Drain Cock
- 4 – Seawater Pump Cover
- 5 – Seawater Drain Cock

### NOTICE

If seawater is left inside, it may freeze and damage parts of the cooling system (heat exchanger, seawater pump, etc.) when ambient temperature is below 32°F (0°C).

1. Close the seacock.
2. Open the seawater drain cocks and drain off the seawater.
3. Remove four bolts attaching the side cover of the seawater pump. Remove the cover and drain the seawater.
4. Install cover and tighten bolts.
5. Close all the drain cocks.



## RETURNING THE ENGINE TO SERVICE

1. Replace the oil and the oil filter before running the engine.
2. Supply fuel if the fuel in the fuel tank was removed, and prime the fuel system.
3. Confirm that there is engine coolant in the engine.
4. Operate the engine at idle speed for 1 minute.
5. Check fluid levels and check engine for leaks.

**This Page Intentionally Left Blank**

# **SPECIFICATIONS**

---

# SPECIFICATIONS

## PRINCIPAL ENGINE SPECIFICATIONS

Specification		6LPA-STP2	6LPA-STZP2
Type		Vertical water-cooled 4-cycle diesel engine	
Number of cylinders		6	
Bore x stroke		94 mm x 100 mm 3.7 in. x 3.94 in.	
Displacement		4.164 L	
Continuous power at crankshaft		211 kW (286 hp) / 3682 rpm	
Maximum output rating*		232 kW (315 hp) / 3800 rpm*	
High idle		4280 ± 25 rpm	
Low idle		750 + 25 / 0	
Combustion System		Direct injection	
Starting System		Electric start (12V - 2.5 kW)	
Charging System		Alternator with built-in regulator 12V DC - 80A	
Direction of Rotation		Counterclockwise (viewed from flywheel)	
Cooling System		Constant high temperature fresh water cooling (2 systems: seawater and fresh water cooling)	
• Cooling water capacity		13.5 L. (14.3 qt) engine 1.6 L (1.7 qt) coolant recovery tank	
Lubrication System		Forced lubrication system with trochoid gear pump	
• Engine (lube) oil capacity	Total	10.5 L (11.0 qt)	
	Oil Pan	8.4 L (8.9 qt)	
Turbocharger	Model	RHE62W (IHI made)	
	Type	Water-cooled turbine housing	
Dimensions (less gear)	L x W x H	1065 x 671 x 729 mm 41.9 x 26.4 x 28.7 in.	1145 x 752 x 799 mm 45.1 x 29.6 x 31.5 in.
		Weight (less gear)	408 kg (899 lb)
Recommended battery capacity		12V x 120 Ah	
Recommended remote control handle		Single-lever-type only	
Engine installation		Flexible engine mount	

\* Density of fuel: 0.840 g/cm<sup>3</sup> at 15°C at the inlet of the fuel injection pump. Rating condition: ISO 3046-1, 8665.

Note: 1 hp metric = 0.7355 kW

### Output Power

Specific Gravity	Fuel Temperature	
	25°C 77°F	40°C 104°F
0.860	323	306
0.840	315	299

**Marine Drive Specifications (Optional)**







Model	Hurth	Kanzaki			Mercruiser		
	ZF63A1	KMH50A	KMH50V	ZT370	Bravo X-1	Bravo X-2	Bravo X-3
Type	8° down Hydraulic		12° down Hydraulic	Stern Drive			
Applicable engine	6LPA-STP2			6LPA-STZP2			
Reduction ratio	1.22 / 1.21	1.67 / 1.67	1.22 / 1.22	1.65	1.36	1.50	1.36
ZF63A1: Ahead / Astern	1.56 / 1.58	2.13 / 2.13	1.58 / 1.58	1.78	1.50	1.65	1.50
Bravo X-1, 2, 3: Both Ahead / Astern	2.04 / 2.10	2.43 / 2.43	2.08 / 2.08	-	-	1.81	1.65
	2.52 / 2.53	-	2.47 / 2.47	-	-	2.00	1.81
See manufacturer's documentation for additional information.							

**This Page Intentionally Left Blank**

# SYSTEM DIAGRAMS

---

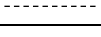
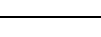
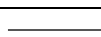
## PIPING DIAGRAMS

Notation	Description
	Screw Joint (Union)
	Flange Joint
	Eye Joint
	Insertion Joint
	Drilled Hole
	Coolant Piping
	Cooling Seawater Piping
	Lubricating Oil Piping
	Diesel Fuel Piping

Note: Fuel rubber pipes (marked \*) satisfy EN / ISO7840.

6LPA-STP2

0006321

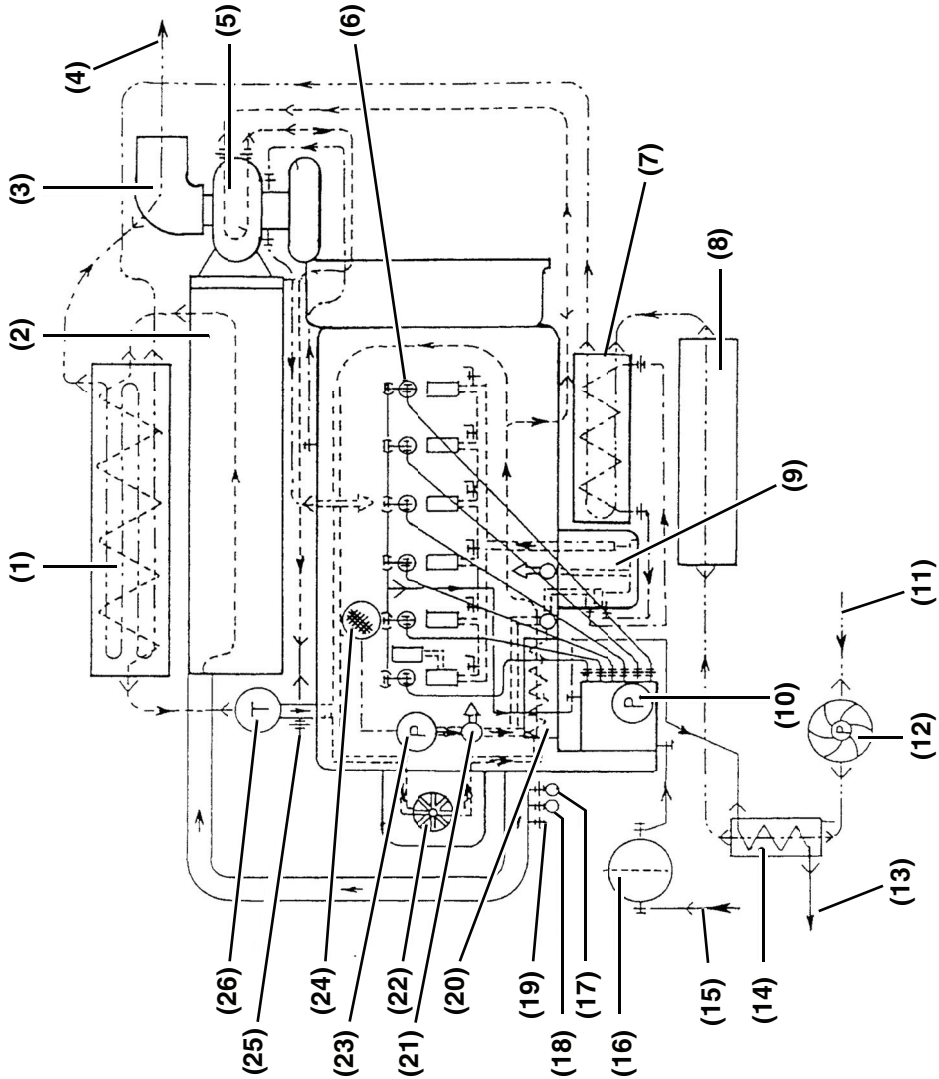

Figure 1



- 1 – Heat Exchanger
- 2 – Exhaust Manifold
- 3 – Mixing Elbow
- 4 – Seawater Outlet
- 5 – Turbocharger
- 6 – Fuel Injection Valves
- 7 – Engine Oil Cooler
- 8 – Charge Air Cooler
- 9 – Engine Oil Filter
- 10 – Fuel Injection Pump
- 11 – Seawater Inlet (from Seacock)
- 12 – Seawater Pump
- 13 – Fuel Return Pipe (to Fuel Tank)
- 14 – Diesel Fuel Cooler
- 15 – Diesel Fuel Inlet  
(from Fuel Tank)
- 16 – Diesel Fuel Filter
- 17 – Coolant Temperature Sender  
(Optional)
- 18 – Coolant Temperature Switch
- 19 – Coolant Outlet to Heater
- 20 – Engine Oil Cooler Relief Valves
- 21 – Safety Valve
- 22 – Coolant Pump
- 23 – Engine Oil Pump
- 24 – Engine Oil Inlet Filter
- 25 – Coolant Inlet from Heater
- 26 – Thermostat

6LPA-STZP2

0006322

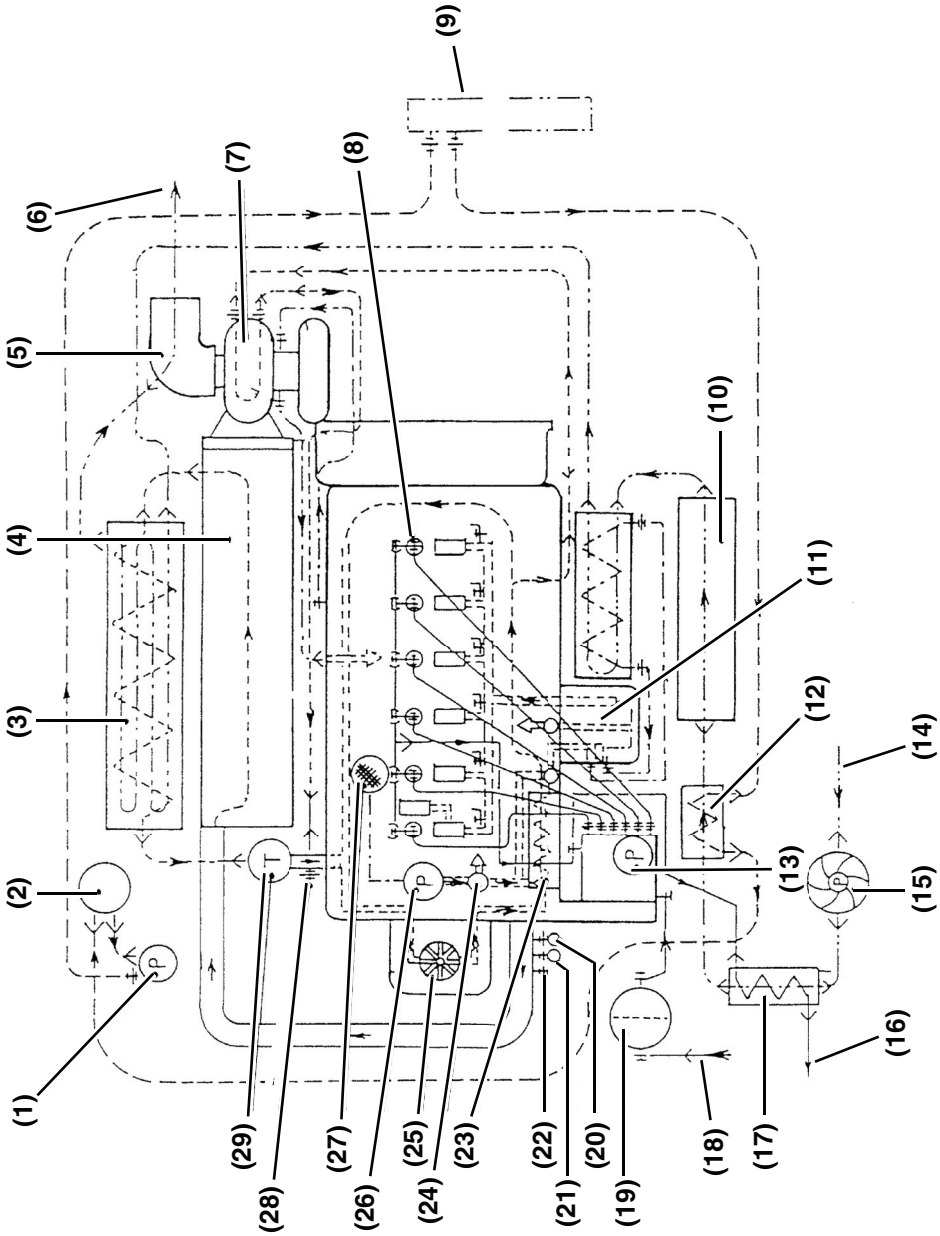

Figure 2

- 1 – Power Steering Oil Pump
- 2 – Power Steering Oil Tank
- 3 – Heat Exchanger
- 4 – Exhaust Manifold
- 5 – Mixing Elbow
- 6 – Seawater Outlet
- 7 – Turbocharger
- 8 – Fuel Injection Valves
- 9 – Power Steering Cylinder Unit  
(Local Supply)
- 10 – Intercooler
- 11 – Engine Oil Filter
- 12 – Power Steering Oil Cooler
- 13 – Fuel Injection Pump
- 14 – Sea Water Inlet (from Seacock)
- 15 – Seawater Pump
- 16 – Diesel Fuel Return Pipe  
(to Fuel Tank)
- 17 – Diesel Fuel Cooler
- 18 – Diesel Fuel Inlet  
(from Fuel Tank)
- 19 – Diesel Fuel Filter
- 20 – Coolant Temperature Sender  
(Optional)
- 21 – Coolant Temperature Switch
- 22 – Coolant Outlet to Heater
- 23 – Engine Oil Cooler Relief Valves
- 24 – Safety Valve
- 25 – Coolant Pump
- 26 – Engine Oil Pump
- 27 – Engine Oil Inlet Filter
- 28 – Coolant Inlet from Heater
- 29 – Thermostat

**This Page Intentionally Left Blank**

**WIRING DIAGRAMS**

Allowable length by cross sectional area of battery cable	
Section of cable mm <sup>2</sup> (in. <sup>2</sup> )	Allowable length L = 1 + 2 + 3 m (ft.)
15 (0.023)	< 0.86 (0.26)
20 (0.031)	< 1.3 (0.40)
30 (0.046)	< 2.3 (0.70)
40 (0.062)	< 2.8 (0.85)
50 (0.077)	< 3.5 (1.07)
60 (0.093)	< 4.1 (1.25)

B-Type Instrument Panel

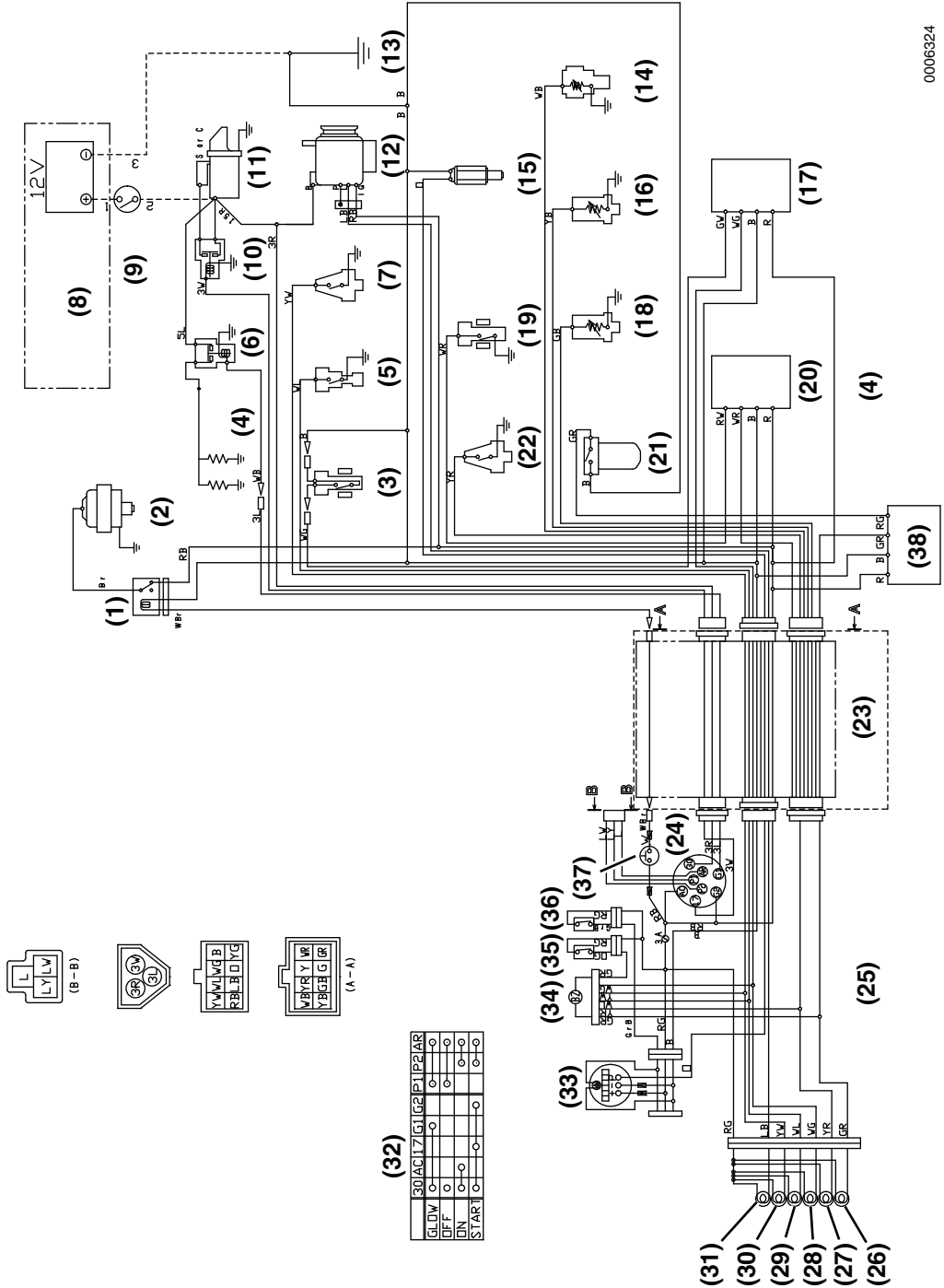

0006324

Figure 3

- 1 – Relay
- 2 – Engine Stop Solenoid
- 3 – Seawater Flow Switch
- 4 – Grouping (Option)
- 5 – Coolant Temperature Switch
- 6 – Relay
- 7 – Engine Oil Pressure Switch
- 8 – Procured by Customer
  - 1+2+3<2.5 m – 20 mm<sup>2</sup>
  - 1+2+3< 5 m – 40 mm<sup>2</sup> (Cross Sectional Area)
- 9 – Battery Switch
- 10 – Starter Relay
- 11 – Starter
- 12 – Alternator
- 13 – Ground
- 14 – Coolant Temperature Sender
- 15 – Tachometer Sensor
- 16 – Engine Oil Pressure Sensor
- 17 – Timer Controller (Seawater Flow Switch)
- 18 – Boost Sender
- 19 – Coolant Level Switch
- 20 – Timer Controller (Coolant Level Switch)
- 21 – Fuel Filter Switch
- 22 – Boost Switch
- 23 – Wire Harness (Option)
- 24 – Starter Switch
- 25 – Instrument Panel
- 26 – Fuel Filter
- 27 – Boost
- 28 – Exhaust
- 29 – Coolant Temperature
- 30 – Engine Oil Pressure
- 31 – Charge
- 32 – Output status table
- 33 – Tachometer with Hour Meter
- 34 – Buzzer
- 35 – Buzzer Stop
- 36 – Illuminate
- 37 – Stop Switch
- 38 – Timer Controller (Fuel Filter Switch)





- 1 – Tachometer with Hour Meter
- 2 – Buzzer
- 3 – Buzzer Stop
- 4 – Illuminate
- 5 – Starter Switch
- 6 – Stop Switch
- 7 – Relay
- 8 – Relay
- 9 – Engine Stop Solenoid
- 10 – Air Heater
- 11 – Heater Controller
- 12 – Coolant Temperature Switch
- 13 – Engine Oil Pressure Switch
- 14 – Starter Relay
- 15 – Coolant Temperature Switch
- 16 – Procured by Customer  
 $1+2+3 < 2.5 \text{ m} - 20 \text{ mm}^2$   $1+2+3 < 5$   
 $\text{m} - 40 \text{ mm}^2$  (Cross Sectional  
 Area)
- 17 – Battery
- 18 – Battery Switch
- 19 – Starter
- 20 – Alternator
- 21 – Ground
- 22 – 6LPA-DTZP, STZP, STZP2
- 23 – For 6LPA-DTZP, STZP, STZP2
- 24 – Gear Oil Level Switch
- 25 – Coolant Temperature Sender
- 26 – Engine Oil Pressure Sender
- 27 – Tachometer Sensor
- 28 – Boost Sender
- 29 – For 6LPA-DTZP, STZP, STZP2
- 30 – 6LPA-DTZP, STZP, STZP2
- 31 – Coolant Level Switch
- 32 – Drive Trim Sender
- 33 – Timer Controller  
(Coolant Level Switch)
- 34 – Fuel Filter Switch
- 35 – Wire Harness for 2-panel
- 36 – Wire Harness
- 37 – Starter Switch
- 38 – Stop Switch
- 39 – Illuminate
- 40 – Buzzer Stop
- 41 – Buzzer
- 42 – Instrument Panel
- 43 – Tachometer with Hour Meter
- 44 – Coolant Temperature Meter
- 45 – Engine Oil Pressure Meter
- 46 – Charge
- 47 – Output startus table
- 48 – Gear Oil
- 49 – Fuel Emp
- 50 – Fuel Filter
- 51 – Boost
- 52 – Diesel Preheat
- 53 – Coolant Level
- 54 – Exhaust
- 55 – Coolant Temperature
- 56 – Engine Oil Pressure
- 57 – Option: Harness Adapter, Trim  
Meter 119778-91500
- 58 – Recommendation: Marcruiser  
79-817033A 4
- 59 – Trim Meter
- 60 – Boost Meter
- 61 – Fuel Filter
- 62 – Diesel Preheat
- 63 – Exhaust
- 64 – Coolant Temperature
- 65 – Engine Oil Pressure
- 66 – Timer Controller  
(Fuel Filter Switch)

C/D-Type x C-Type Instrument Panel

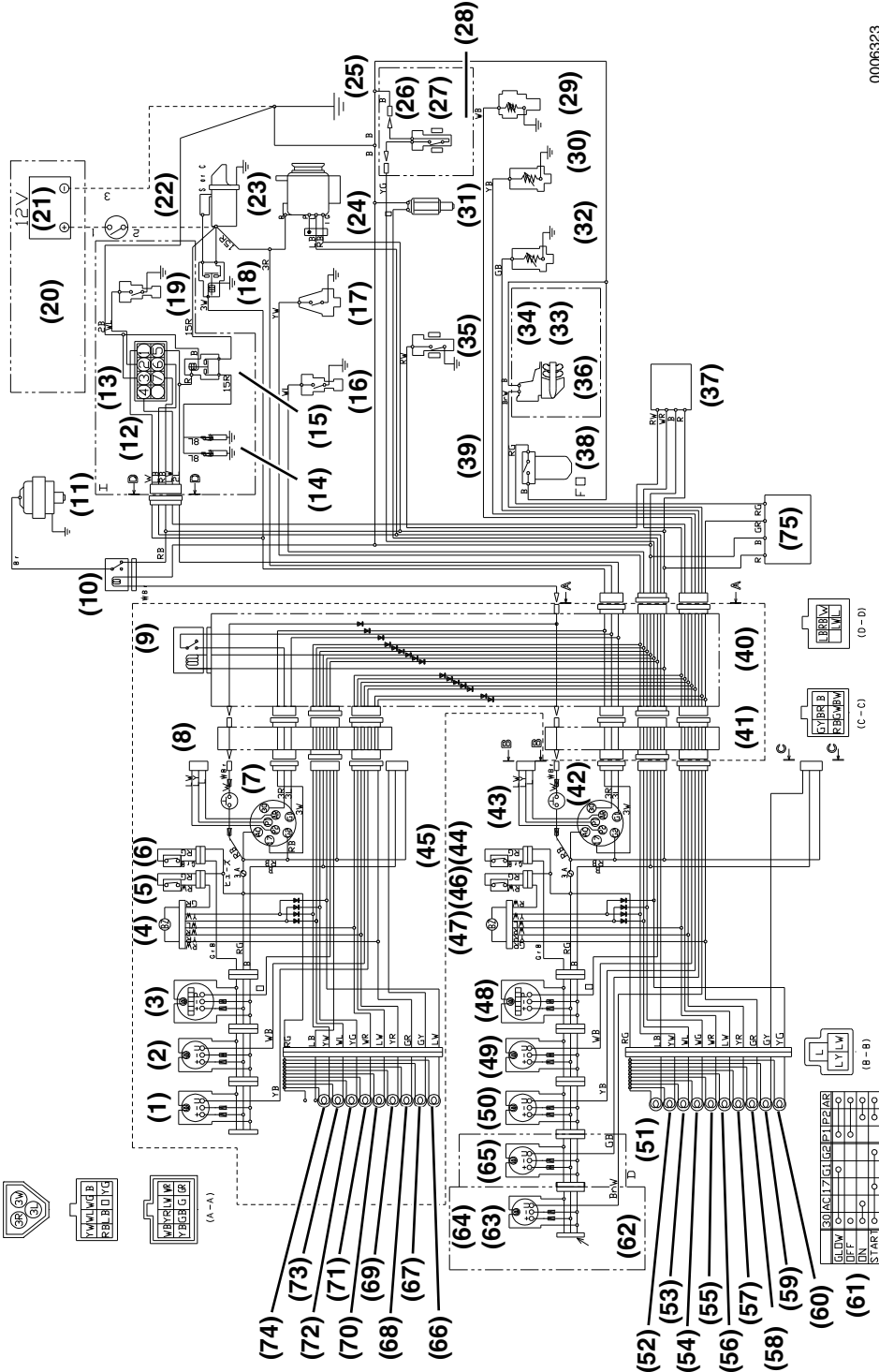

0006323

Figure 5

- 1 – Engine Oil Pressure Meter
- 2 – Coolant Temperature Meter
- 3 – Tachometer with Hour Meter
- 4 – Buzzer
- 5 – Buzzer Stop
- 6 – Illuminate
- 7 – Starter Switch
- 8 – Stop Switch
- 9 – Relay
- 10 – Relay
- 11 – Engine Stop Solenoid
- 12 – Air Heater (Option)
- 13 – Heater Controller
- 14 – Heater Plug
- 15 – Relay
- 16 – Coolant Temperature Switch
- 17 – Engine Oil Pressure Switch
- 18 – Starter Relay
- 19 – Coolant Temperature Switch
- 20 – Procured by Customer  
     1+2+3<2.5 m – 20 mm<sup>2</sup> 1+2+3<5  
     m – 40 mm<sup>2</sup> (Cross Sectional  
     Area)
- 21 – Battery
- 22 – Battery Switch
- 23 – Starter
- 24 – Alternator
- 25 – Ground
- 26 – 6LPA-DTZIP, STZP, STZP2
- 27 – For 6LPA-DTZIP, STZP, STZP2
- 28 – Gear Oil Level Switch
- 29 – Coolant Temperature Sender
- 30 – Engine Oil Pressure Sender
- 31 – Tachometer Sensor
- 32 – Boost Sender
- 33 – For 6LPA-DTZIP, STZP, STZP2
- 34 – 6LPA-DTZIP, STZP, STZP2
- 35 – Coolant Level Switch
- 36 – Drive Trim Sender
- 37 – Timer Controller  
     (Coolant Level Switch)
- 38 – Fuel Filter Switch
- 39 – Boost
- 40 – Wire Harness for 2-Panel
- 41 – Wire Harness
- 42 – Starter Switch
- 43 – Stop Switch
- 44 – Illuminate
- 45 – Instrument Panel (No. 2  
     Station) Option
- 46 – Buzzer Stop
- 47 – Buzzer
- 48 – Tachometer with Hour Meter
- 49 – Coolant Temperature Meter
- 50 – Engine Oil Pressure Meter
- 51 – Charge
- 52 – Engine Oil Pressure
- 53 – Coolant Temperature
- 54 – Exhaust
- 55 – Coolant Level
- 56 – Diesel Preheat
- 57 – Boost
- 58 – Fuel Filter
- 59 – Fuel Emp
- 60 – Gear Oil
- 61 – Output status table
- 62 – 119778–91500 Option:  
     Harness Adaptor, Trim Meter  
     119778–91500
- 63 – 79–817033A 4  
     Recommendation: Marcruiser  
     79–817033A 4
- 64 – Trim Meter
- 65 – Boost Meter
- 66 – Gear Oil
- 67 – Fuel Emp
- 68 – Fuel Filter
- 69 – Boost
- 70 – Diesel Preheat
- 71 – Coolant Level
- 72 – Exhaust
- 73 – Coolant Temperature
- 74 – Engine Oil Pressure
- 75 – Timer Controller  
     (Fuel Filter Switch)

**This Page Intentionally Left Blank**

# WARRANTY SERVICE

## Owner Satisfaction

Your satisfaction and good will are important to your dealer and to us.

Normally, any problems concerning the product will be handled by our dealer's service department. If you have a warranty problem that has not been handled to your satisfaction, we suggest you take the following action:

- Discuss your problem with a member of dealership management. Often complaints can be quickly resolved at that level. If the problem has already been reviewed with the Service Manager, contact the owner of the dealership or the General Manager.
- If your problem still has not been resolved to your satisfaction, contact your Yanmar local Subsidiary Company.

We will need the following information in order to assist you:

- Your name, address and telephone number
- Product model and serial number (see the name plate affixed on the engine)
- Date of purchase
- Dealer name and address
- Nature of problem

After reviewing all the facts involved, you will be advised of what action can be taken. Please bear in mind that your problem will likely be resolved at the dealership, using the dealer's facilities, equipment and personnel, so it is very important that your initial contact will be with the dealer.

User's record

Date of purchase
Place of purchase (Name of dealer)

**Declaration of Conformity for Recreational Craft Propulsion Engine with the Exhaust emission requirements of Directive 94/25/EC as amended by 2003/44/EC**  
(To be completed by manufacturer of inboard engines without integral exhaust)

Name of engine manufacturer: Yanmar Co., Ltd.  
 Street: 1-32 Town: Chayamachi, Kitaku, Osaka-City  
 Post Code: 530-8311 Country: Japan

Name of Authorised Representative: Yanmar Co.,Ltd. Marine Operations Division  
 Street: 5-3-1 Town: Tsukaguchi Honmachi, Amagasaki, Hyogo  
 Post Code: 661-0001 Country: Japan

Name of Notified Body for exhaust emission assessment: Société Nationale de Certification et d'Homologation  
 Street: 11, route de Luxembourg Town: Sandweiler  
 Post Code: L-5230 Country: Luxembourg ID Number: 0499

Module used for exhaust emission assessment:  B+C  B+D  B+E  B+F  G  H  
 or engine type-approved according to:  stage II of Directive 97/68/EC  Directive 88/77/EC  
 Other Community Directives applied: 2004/108/EC

**DESCRIPTION OF ENGINE(S) AND ESSENTIAL REQUIERMENTS**

**Engine Type:**  z or sterndrive without integral exhaust  Inboard engine  
**Fuel Type:**  Diesel  Petrol  
**Combustion cycle:**  2 stroke  4 stroke

Essential requirements	Standards Used	Other normative document used	See technical file
<b>Annex I.B – Exhaust Emissions</b>			
engine identification			
exhaust emission requirements	EN ISO 8178-1:1996		X
durability			
owner's manual			
<b>Annex I.C – Noise Emissions</b>	see craft manufacturer's Declaration of Conformity		

**ENGINE(S) COVERED BY THIS DECLARATION**

Engine model(s) or engine family name(s):	EC Type certificate number (exhaust)
	SNCH*94/25*2003/44*
RCD-1GM10X1	0009*00
RCD-2YM15X1	0004*02
RCD-3YM30X1	0005*02
RCD-4JH4X1	0014*01
RCD-4JH3TX1	0011*01
RCD-4LHAX1	0015*00
RCD-6LPADX1	0012*00
RCD-6LPASX1	0007*00
RCD-6CXMX1	0006*00
RCD-6LY2X1	0008*00
RCD-6LY3X1	0010*04
RCD-4JH3TX2	0016*00
RCD-4JH4TX2	0017*01
RCD-4JH4TX1	0018*02
RCD-6LPASX2	0023*01
RCD-4JH4AX1	0025*02
RCD-6CX53X1	0028*01
RCD-4JH5X1	0029*00
RCD-3JH5X1	0030*00
RCD-8LVX1	0038*00

I declare on behalf of the engine manufacturer that the engine(s) will meet the exhaust emission requirements of Directive 94/25/EC as amended by Directive 2003/44/EC when installed in a recreational craft, in accordance with the engine manufacturer's supplied instructions and that this (these) engine(s) must not be put into service until the recreational craft into which it is (they are) to be installed has been declared in conformity with the relevant provisions of the above mentioned Directive.

Name: Mitsuo Kaji Signature and title: M. Kaji  
 (identification of the person empowered to sign on behalf of the engine manufacturer or his authorised representative) (or an equivalent marking) Senior Manager

Small Marine Engine Development Dept.  
 Marine Operations Division  
 Yanmar Co.,Ltd.

Date: (yr/month/day) 2011 / 11 / 11

**Declaration of Conformity for Recreational Craft Propulsion Engine with the Exhaust and Noise emission requirements of Directive 94/25/EC as amended by 2003/44/EC**  
(To be completed by manufacturer of outboard or inboard engines with integral exhaust)

Name of engine manufacturer: Yanmar Co., Ltd.

Street: 1-32 Town: Chayamati, Kitaku, Osaka-City

Post Code: 530-8311 Country: Japan

Name of Authorised Representative ( if applicable): Yanmar Co.,Ltd. Marine Operations Division

Street: 5-3-1 Town: Tsukaguchi Honmachi, Amagasaki, Hyogo

Post Code: 661-0001 Country: Japan

Name of Notified Body for exhaust emission assessment: Société National de Certification et d'Homologation

Street: 11, route de Luxembourg Town: Sandweiler

Post Code: L-5230 Country: Luxembourg ID Number: 0499

Name of Notified Body for noise emission assessment: Dutch Certification Institute (DCI)

Street: Nipkowweg 9 Town: Joure

Post Code: 8500 AB Country: The Netherlands ID Number: 0613

Module used for exhaust emission assessment: B+C  B+D  B+E  B+F  G  H   
or engine type-approved according to:  stage II of Directive 97/68/EC  Directive 88/77/EC

Module used for noise emission assessment: Aa  G  H

Other Community Directives applied: 2004/108/EC

**DESCRIPTION OF ENGINE(S) AND ESSENTIAL REQUIERMENTS**

Engine Type:  Outboard  z or sterndrive with integral exhaust  
Fuel Type:  Diesel  Petrol  
Combustion cycle:  2 stroke  4 stroke

**ENGINE(S) COVERED BY THIS DECLARATION**

Engine model(s) or engine family name(s):	EC Type certificate number (exhaust)
	SNCH*94/25*2003/44*
RCD-4LHAX1	0015*00
4LHA-HTZP	
RCD-6LY2X1	0008*00
4LHA-DTZP	
4LHA-STZP	
RCD-6LPADX1	0012*00
6LPA-DTZP	
RCD-6LPASX1	0007*00
6LPA-STZP	
RCD-6LPASX2	0023*01
6LPA-STZP2	
RCD-8LVX1	0038*00
8LV320Z	
8LV350Z	
8LV370Z	

Essential requirements	Standards Used	Other normative document used	See technical file
<b>Annex I.B – Exhaust Emissions</b>			
engine identification (I.B.1)			<input type="checkbox"/>
exhaust emission requirements	EN ISO 8178-1:1996		<input checked="" type="checkbox"/>
durability			<input type="checkbox"/>
owner's manual			<input type="checkbox"/>
<b>Annex I.C – Noise Emissions</b>			
Noise emission levels (I.C.1)	EN ISO 14509		<input checked="" type="checkbox"/>
owner's manual (I.C.2)			<input type="checkbox"/>

I declare on behalf of the engine manufacturer that the engine(s) mentioned above complie(s) with all applicable essential requirements in the way specified and is in conformity with the type for which above mentioned EC type examination certificate(s) has been issued.

Name: Yukio Kikuchi Signature and title: \_\_\_\_\_  
(identification of the person empowered to sign on behalf of the engine manufacturer or his authorised representative) (or an equivalent marking)

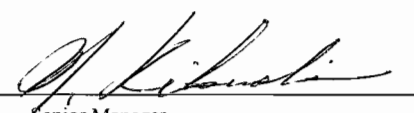
  
Senior Manager  
Application Engineering Dept.  
Marine Operations Division  
Yanmar Co.,Ltd.

Date: (yr/month/day) 2011 / 6 / 29





# **YANMAR CO., LTD.**

## ■ Yanmar (Head office)

Umeda Gate Tower 1-9 Tsurunocho, kita-ku, Osaka,  
Japan 530-8311

## ■ Marine Operations Division

### Quality Assurance Dept.

3-1, 5-Chome, Tsukaguchi-honmachi, Amagasaki,  
Hyogo, Japan 661-0001  
Phone: +81-6-6428-3251 Fax: +81-6-6421-5549

---

## Overseas Office

---

## ■ Yanmar Europe B.V. (YEU)

Brugplein 11, 1332 BS Almere-de Vaart, Netherlands  
Phone: +31-36-5493200 Fax: +31-36-5493209

## ■ Yanmar Asia (Singapore) Corporation Pte Ltd. (YASC)

4 Tuas Lane, Singapore 638613  
Phone: +65-6595-4200 Fax: +65-6862-5189

## ■ Yanmar America Corporation (YA)

101 International Parkway  
Adairsville, GA 30103, U.S.A.  
Phone: +1-770-877-9894 Fax: +1-770-877-9009

## ■ Yanmar Engine (Shanghai). Co., Ltd.

10F, E-Block POLY PLAZA, No.18 Dongfang Road,  
Pudong Shanghai, CHINA P.R.C. 200120  
Phone: +86-21-6880-5090 Fax: +86-21-6880-8090

## OPERATION MANUAL

6LPA-STP2, 6LPA-STZP2

1st edition: December 2010

2nd edition: April 2011

2nd edition 1st rev.: August 2011

2nd edition 2nd rev.: January 2012

Issued by: YANMAR CO., LTD. Marine Operations Division

Edited by: YANMAR TECHNICAL SERVICE CO., LTD.



**MARINE ENGINE**

**YANMAR**

**YANMAR CO., LTD.**

<http://www.yanmar.com>

0A6LP-G00103